

NT370

SERIES

Tunable Wavelength Infrared Lasers

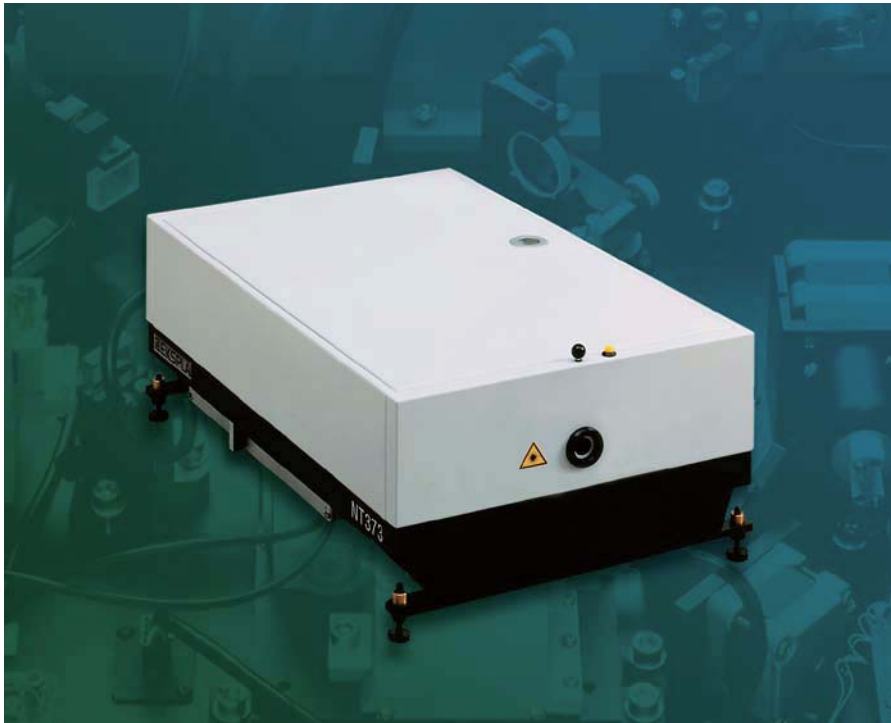

NT370 series tunable laser seamlessly integrates in a compact housing the nanosecond optical parametric oscillator and Nd:YAG Q-switched laser.

Pumped by fundamental harmonics output the lasers provides the tuning in mid- and far-infrared spectral range.

NT373 model produces eye-safe output at 1.57 μm . NT373-XIRx model uses the output from eye-safe OPO to pump AgGaSe₂ crystal based cascade OPO for tunable output in 4.1-12 μm range. Several sets of optics should be used to cover the whole tuning range; the standard ranges of 4.1-6, 6-12 and 5-11 μm are available. Customized tuning ranges are available by request. The linewidth of NT373-XIRx model is nearly constant across tuning range and less than 6 cm^{-1} .

NT377 model produces tunable output in 2.5-4.4 μm range. Pulse energy is exceeding 10 mJ for wavelengths shorter than 3.6 μm , while linewidth is below 10 cm^{-1} for the wavelengths longer than 3 μm .

Because of narrow linewidth of output radiation (typically in 6-10 cm^{-1} range) the laser is suitable for many infrared spectroscopic applications, for example cavity ring-down spectroscopy, gas detection and remote sensing.

The device is controlled from the remote keypad or from PC through RS232 interface using LabView drivers that are supplied with the system. The remote pad features a backlit display that is easy to read even while wearing laser safety glasses.

System is designed for easy and cost-effective maintenance. Replacement of flashlamps can be done without misalignment of the laser cavity and deterioration of laser performance. OPO pump energy monitoring system helps to increase lifetime of the optical components.

FEATURES

- Hands-free, automated wavelength tuning
- Up to 15 mJ pulse energy in mid-IR spectral range
- Less than 10 cm^{-1} linewidth for most of the tuning range
- 3–5 ns pulse duration
- 10 or 20 Hz pulse repetition rate
- Remote control pad
- PC control via RS232 and LabView™ drivers
- Separate output port for 1064 nm pump beam
- OPO pump energy monitoring
- Replacement of the flashlamps is done without misalignment of the laser cavity

APPLICATIONS

- Infrared spectroscopy
- Cavity ring-down spectroscopy
- Remote sensing
- Material processing
- Non-linear spectroscopy
- Other laser spectroscopy applications

SPECIFICATIONS ¹⁾

MODEL	NT377A	NT373	NT373-XIR
OPO			
Wavelength range	2500–4400 nm	1570 nm	4100–12000 nm ²⁾
Output pulse energy ³⁾	12.5 mJ	50 mJ	1 mJ
Linewidth ⁴⁾	< 10 cm ⁻¹	< 3 cm ⁻¹	< 6 cm ⁻¹
Scanning step	1 nm	—	1 nm
Typical pulse duration ⁵⁾		3–5 ns	
Typical beam diameter ⁶⁾	6 mm	6 mm	8 mm
Polarization	horizontal	vertical	horizontal
PUMP LASER ⁷⁾			
Pump wavelength		1064 nm	
Max pump pulse energy		300 mJ	
Pulse duration		4–6 ns	
Beam quality		"Hat-Top" in near field	
Beam divergence		< 0.5 mrad	
Pulse energy stability (StDev)		< 1 %	
Pulse repetition rate		10 or 20 Hz	
PHYSICAL CHARACTERISTICS			
Unit size (W×H×L)	450×270×1020 mm	450×270×610 mm	450×270×1020 mm
Power supply size (W×H×L)		330×670×520 mm	
Umbilical length		2.5 m	
OPERATING REQUIREMENTS			
Water consumption (max 20 °C) ^{8) 9)}		10 l/min	
Room temperature		18–27 °C	
Relative humidity (noncondensing)		20–80 %	
Mains voltage ¹⁰⁾		208 or 240 V AC, single phase, 50/60 Hz	
Power consumption ⁹⁾		1.5 kVA	

- All specifications are subject to change without notice. Parameters marked typical are not specifications. They are indications of typical performance and will vary with each unit we manufacture. Unless stated otherwise all specifications are measured at 3000 nm for NT377 unit, at 1570 nm for NT373 unit and at 7.0 μm for NT373-XIRx units.
- The number represents available output wavelength range. Three standard options are available with 4.1-6, 6-12 and 5-11 μm tuning ranges.
- Output is specified at wavelengths defined in chapter 1. See graph below for typical outputs at other wavelengths.
- Linewidth is specified at wavelengths defined in chapter 1. See graph below for typical linewidth at other wavelengths.
- Estimate, assuming that pulse duration from OPO is by approx 1 ns shorter than one from pump laser.
- Beam diameter is measured at the FWHM level at the output aperture and can vary depending on the pump pulse energy.
- Laser output will be optimised for OPO operation and specification may vary with each unit we manufacture.
- Air cooled power supply is available as option.
- For 10 Hz PRR.
- Should be specified when ordering.

OPTIONS

Option	Description
– AW	Water-air cooling option
– 20	20 Hz PRR option
– H	Optional FF output

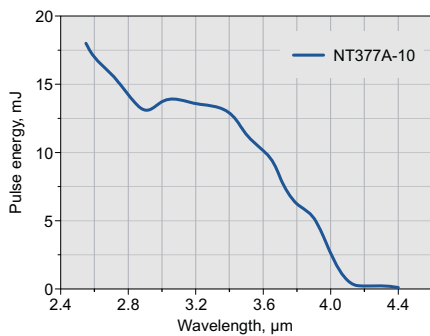

Fig. 1. Typical output energy of the NT377A tunable wavelength laser

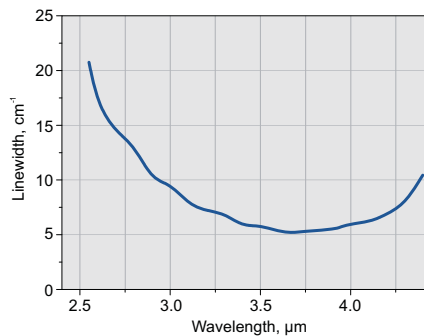

Fig. 2. Typical linewidth of the NT377A tunable wavelength laser

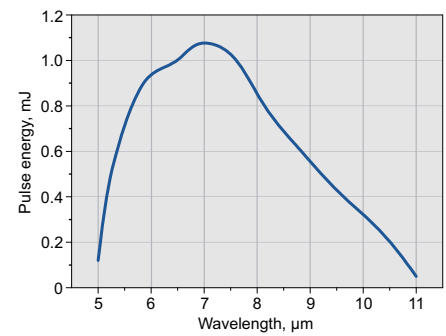

Fig. 3. Typical output pulse energy of the NT373-XIR3 tunable wavelength laser

NOTE: Due to narrow linewidth the tuning curve is affected by ambient air absorption, the curve presents pulse energy when air absorption is negligible.

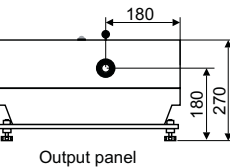
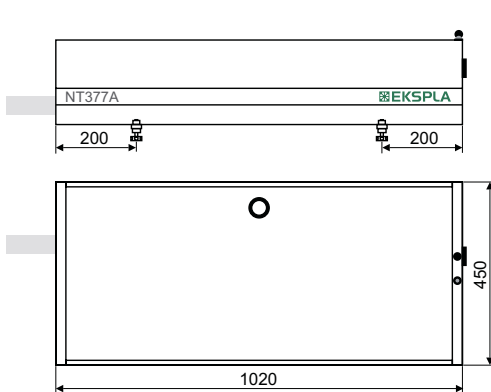

Fig. 4. Dimensions of NT373-XIRx and NT377A lasers

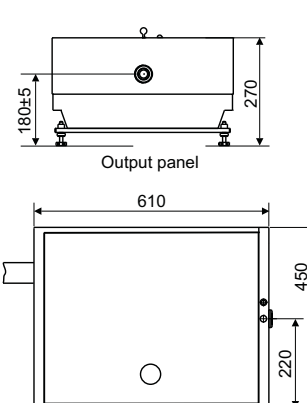

Fig. 5. Dimensions of NT373 laser



EKSPLA
Savanoriu av. 231
02300 Vilnius
LITHUANIA

Ph.: +370 5 2649629
Fax: +370 5 2641809
sales@ekspla.com
www.ekspla.com

PHOTO TECHNICA PHOTOTECHNICA CORP.
TEL:048-871-0067 FAX:048-871-0068,
e-mail: voc@phototechnica.co.jp
http://www.phototechnica.co.jp



ISO 9001
CERTIFIED