

LightWire FFS series

Compact
Fiber Seeders for
Femtosecond Lasers



FEATURES

- ▶ Pulse energy > 250 nJ at repetition rate < 200 kHz
- ▶ Compressed or chirped broadband pulses
- ▶ Down to 300 fs pulses available after compression

APPLICATIONS

- ▶ Seeding femtosecond CPA systems

LightWire FFS series fiber lasers are dedicated for seeding solid state femtosecond Yb:YAG based CPA systems. Ekspla offers FFS lasers either with femtosecond pulse duration directly from fiber, or with chirped pulses. Broad up to 12 nm spectral

bandwidth enables amplification of pulses with < 300 fs compressed duration. Special feature of FFS200CHI laser is customizable chirp profile to match compressor design of the CPA system.

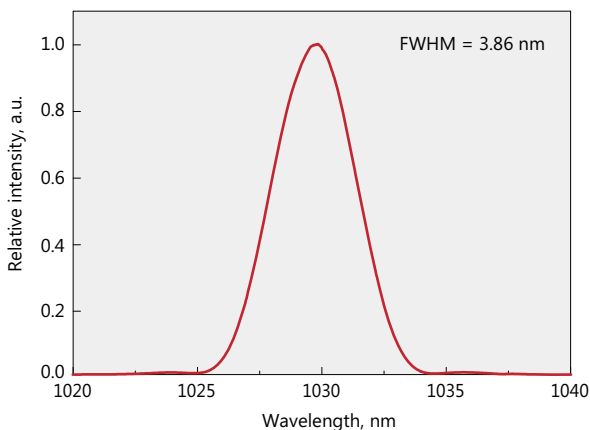

Typical spectrum from FFS10 laser

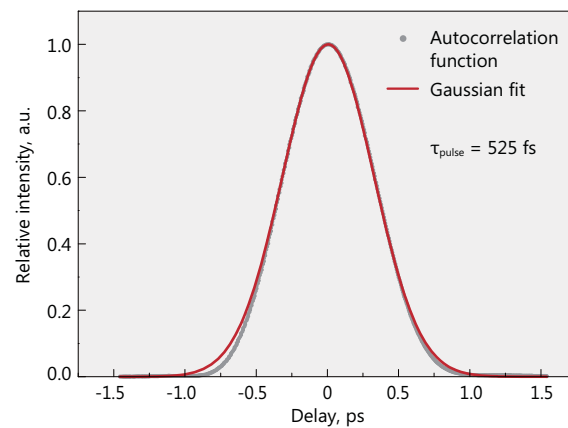

Typical autocorrelation from FFS10 laser

SPECIFICATIONS ¹⁾

Model	FFS10	FFS100CHI	FFS200CHI
Central wavelength	1030 ± 1 nm		
Spectral bandwidth	3.5 ± 0.5 nm	8 ± 1 nm	up to 12 nm
Pulse duration	550 ± 50 fs	7 ± 2 ps (chirped)	> 50 ps (chirped)
Compressed pulse duration	NA	< 300 fs	down to 300 fs
Chirp profile	no chirp	linear	custom ²⁾
Oscillator pulse repetition rate	52 ± 3 MHz		
Pulse repetition rate with pulse picker ³⁾	26 kHz – 52 MHz (PRR = PRR _{osc} / N, N = 1, 5, 6, ..., 2000)		
Output power (without/with pulse picker)	> 1 mW / > 0.5 mW	> 50 mW / > 25 mW	> 200 mW at 10 MHz > 100 mW at 1 MHz > 25 mW at 100 kHz
Pulse energy (without/with pulse picker)	> 20 pJ / > 10 pJ	> 1 nJ / > 0.5 nJ	> 250 nJ at repetition rates < 200 kHz
Polarization	linear, > 100:1 extinction		
Optical output	FC/APC connector or collimator with mounting flange (optional)		collimator & isolator node ⁴⁾
Umbilical	3 m length armored cable Ø5 mm ⁵⁾		
Beam diameter	0.9 ± 0.1 mm or 1.3 ± 0.1 mm or 2.1 ± 0.2 mm		
Beam height	NA	38 mm	
Beam quality	M ² < 1.1		
Pulse train monitoring	photodiode output for oscillator train, TTL synch pulse for laser output (when pulse picker included)		
Dimensions of control unit (L × W × H)	315 × 450 × 95 (stand alone) or 315 × 482 × 95 (19" rack mountable)		
Dimensions of collimator (D × L)	Ø33.02 × 11.76 mm		
Weight	< 10 kg		
Control interface	USB, CAN, RS232, LAN, (WLAN optional)		
Power supply (AC/DC adapter included)	100–240 V, 50–60 Hz AC		
Power consumption	maximal 230 W (typical 60 W)		
Operating conditions	10–30 °C, humidity – not condensing		



¹⁾ Due to continuous improvement all specifications are subject to change without notice.

²⁾ Chirp profile will be optimized by Ekspla to match customer compressor design.

³⁾ Pulse picker is an option for FFS10, FFS100 models. It supports external gating. FFS200CHI includes internal frequency divider, which enables pulse repetition rate reduction but does not support external gating.

⁴⁾ FFS200CHI model is provided with collimator & isolator node with dimensions 104×52×67 mm.

⁵⁾ Other fiber lengths: 1 m, 2 m, 5 m are available on request.

PERFORMANCE

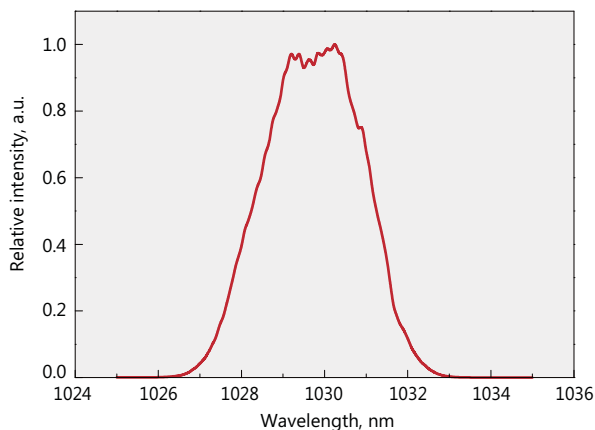

Typical spectrum from FFS200CHI laser

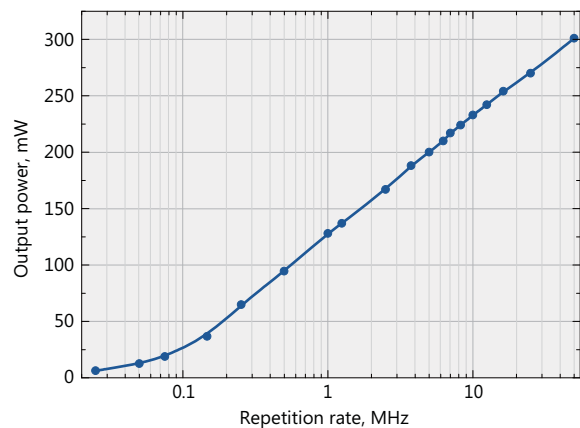

Typical dependence of average power on the repetition rate for FFS200CHI laser

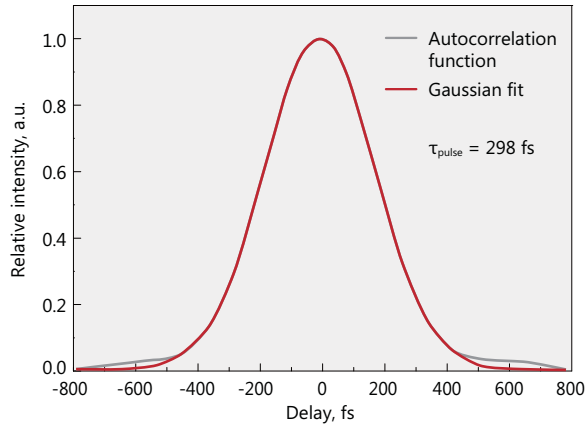

Typical FPS100CHI compressed pulse autocorrelation

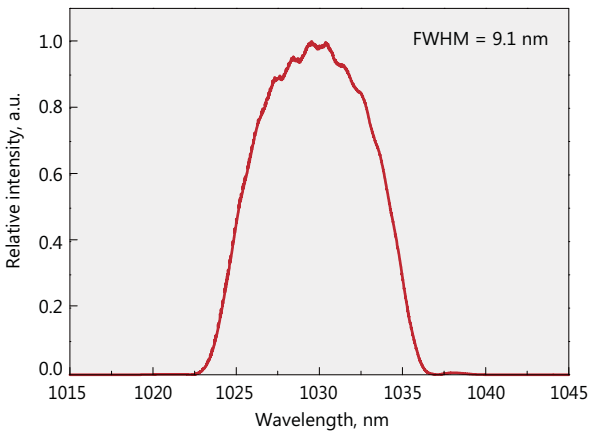

Typical spectrum from FFS100CHI laser

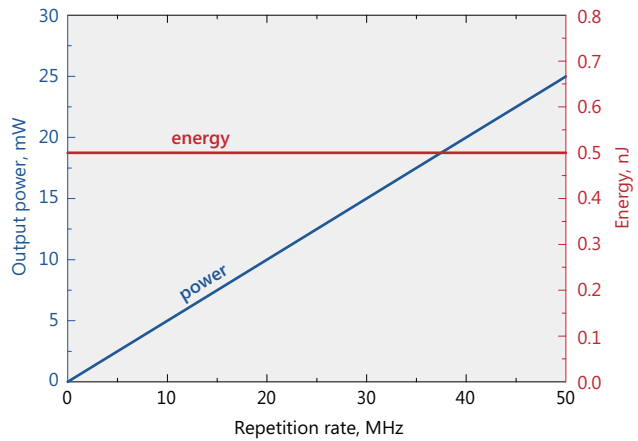

Typical dependence of average power (blue curve) and pulse energy (red curve) on the repetition rate for FFS100CHI-AOM laser

DRAWINGS

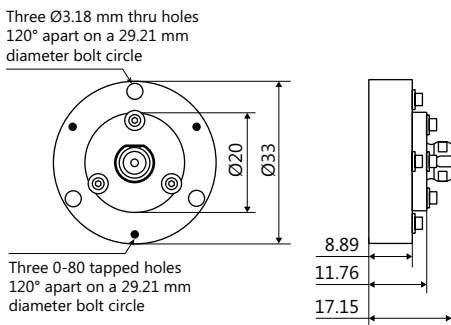
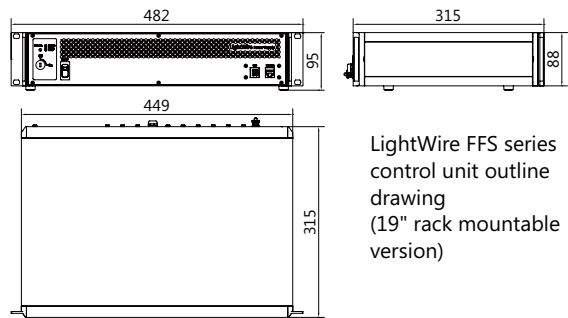
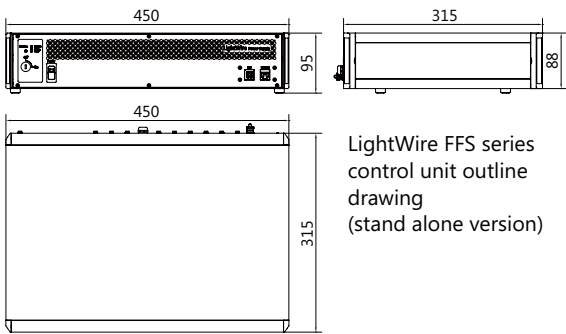

LightWire FFS10/100CHI laser collimator flange outline drawing

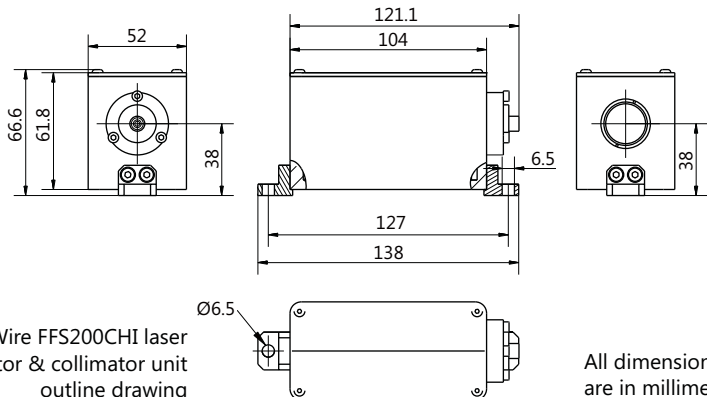

All dimensions are in millimetres.