

waveScan

High Resolution Spectrometer

High Resolution Spinning Grating Spectrometer

waveScan by APE is a compact and cost-efficient spectrometer for ultrafast laser systems, delivering rapid measurements at high spectral resolutions.

The spinning grating technology provides high scan rates, while achieving above average spectral resolution over a wide wavelength range.

Different configurations, from 200 nm UV to 6.3 μm in the mid-infrared range, make waveScan the perfect choice for analyzing the spectrum of different laser types.

Tunable laser systems profit from the wide, octave spanning wavelength ranges that waveScan has to offer.

Automatization is made possible with simple commands directly through USB or via network and TCP/IP.

As an option, waveScan is available with an interchangeable fiber input in addition to a free-space input.

Whether you need fast scan rates for adjustment or high resolution, combined with convenient measurement control and data processing - waveScan is the ideal solution.

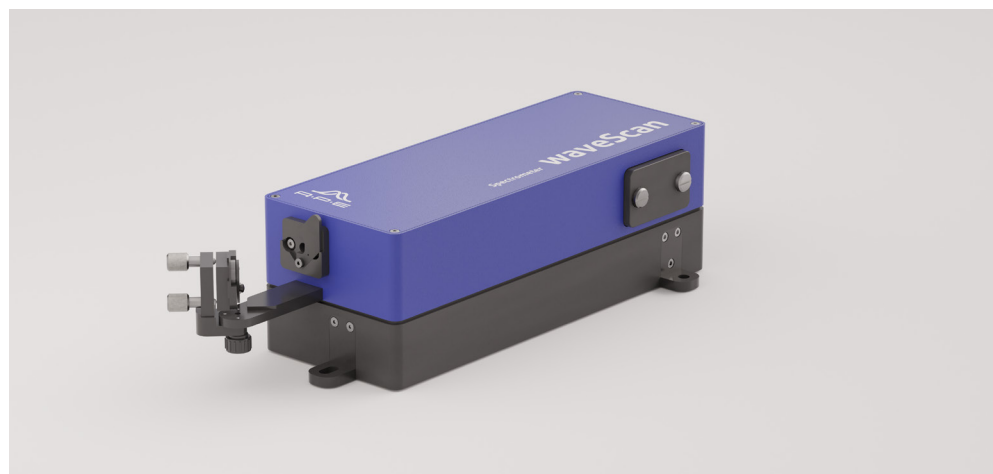

- High spectral resolution up to 0.05 nm depending on the configuration
- Wavelength ranges available from 200 nm - 6300 nm (UV/VIS/NIR/MIR)
- Compact and robust design
- Free-space or fiber input
- Easy to use - plug and play via USB connection; Software included

waveScan Specifications

Specifications

| | | |
|-----------------------|--|-------------------|
| Configuration | Wavelength Range | Resolution (FWHM) |
| | 200 ... 1100 nm | 0.2 nm |
| | 220 ... 540 nm | 0.05 nm |
| | 500 ... 1600 nm | 0.2 nm |
| | 800 ... 2600 nm | 0.5 nm |
| 1500 ... 6300 nm | 3 nm | |
| Scan Rate | - 5 Hz | |
| Laser Repetition Rate | > 4 MHz (real-time measurement) > 100 kHz (accumulation mode) > 100 Hz (triggered mode) | |
| Wavelength Accuracy | ± 0.1 nm (configuration dependent) | |
| Beam Input | Free-space; Optional fiber coupling | |
| Trigger Input | 1 - 100 kHz, BNC connection; 0.2 V to 5 V TTL signal, or photodiode signal (25 nsec rise time) | |
| Input Polarization | Optimized for horizontal polarization (also any other polarization possible) | |
| Connection | USB | |
| Remote Control | Possible via TCP/IP (SCPI command set) or USB commands | |

Options

- Fiber coupling

Dimensions

362 x 91 x 143 mm

waveScan Technical Drawings

All Dimensions in mm

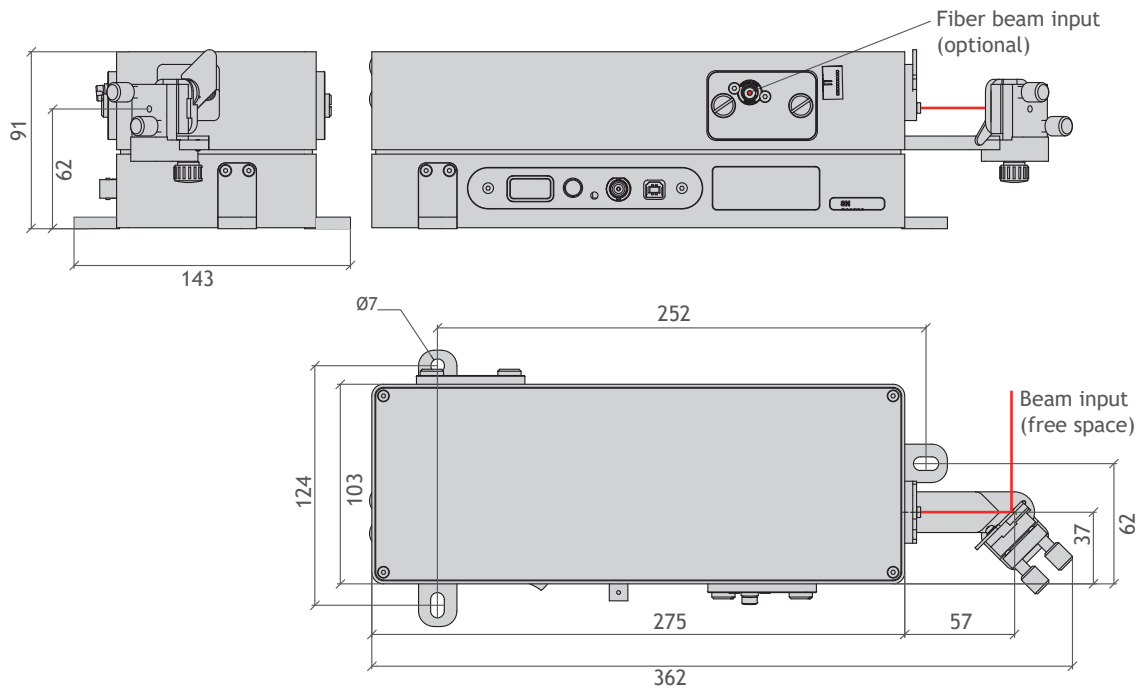

Similar Products

pulseCheck - Autocorrelator multitalent for any task
 Mini TPA - Autocorrelator compact and tuning-free
 Mini PD - Autocorrelator routine tasks with a fixed wavelength range
 Carpe - Autocorrelator first choice for multiphoton microscopy
 Spider - Complete pulse characterization
 peakDetect - Pulse quality monitoring

**PHOTO
TECHNICA** www.phototechnica.co.jp
 フォトテクニカ株式会社
 〒336-0017 埼玉県さいたま市南区南浦和 2-18-2
 TEL:048-871-0067 FAX:048-871-0068
 e-mail:voc@phototechnica.co.jp

Contact

APE Angewandte Physik & Elektronik GmbH

Plauener Str. 163-165 | Haus N | 13053 Berlin | Germany
 T: +49 30 986 011-30
 F: +49 30 986 011-333
 E: sales@ape-berlin.de
 www.ape-berlin.de

APE follows a policy of continued product improvement.
 Therefore, specifications are subject to change without
 notice.

© APE GmbH | Rev. 3.3.4