

# Integrating Spheres

## AvaSphere 30-REFL



An integrating sphere works as a light collector. The light collected can be used as a diffuse illumination or measurement source. The basic principle is that light enters the sphere through the sample port, goes through multiple reflections on the highly reflective, Lambertian surface of the sphere and is scattered uniformly around the interior of the sphere. Behind a baffled port inside the sphere which is independent of the angular properties of the sample port, a fiber-optic cable collects a homogenized light signal and carries it to the spectrometer. The baffle is very significant as it prevents first reflections from entering the detection fiber.

The AvaSphere series integrating spheres are available with active diameters of 30, 50 and 80 mm and an SMA port at 90 degrees for collecting the irradiance and reflection signals. The reflection spheres feature an additional SMA-connector port at 8 degrees from normal (from sample port) for direct illumination. This port couples external light into the sphere through a fiber-optic cable connected to a COL-UV/VIS collimating lens. The sample port diameters are 6 mm for the AvaSphere-30, 10 mm for the AvaSphere-50 and 15 mm for the AvaSphere-80.

All sample ports are knife-edge, ensuring a near 180 degree field of view of the sample port. The irradiance version of the integrat-

ing sphere can be used for measurements of light sources, such as lasers, LEDs and incandescent sources. For irradiance measurements of 5 mm cylindrical LEDs, a special adapter is available for the AvaSphere-50/80-IRRAD. This adapter ensures correct and reproducible positioning of the LEDs inside the sphere.

The AvaSphere reflection version is used for the measurement of total integrated reflectance of a surface, as well as for color measurements and fluorescence spectroscopy on solids/powders. The principle of measurement is based on direct illumination and indirect reflection. The AvaSphere-50-LS-HAL with internal light source can be used as a low-cost uniform source and is available with an intensity calibration file.

The inside of the integrating spheres is made of a highly reflective diffuse PTFE material. This provides over 96% reflectance over a wide wavelength range of 250-2500 nm. For the AvaSphere-50-REFL a special black gloss-trap is available to exclude specular reflection in the measurement. Please order this option when ordering the sphere. In case specular reflection needs to be included, a white reflective part, which is standard on all AvaSphere-50-REFL, can be mounted in the position of the gloss-trap.

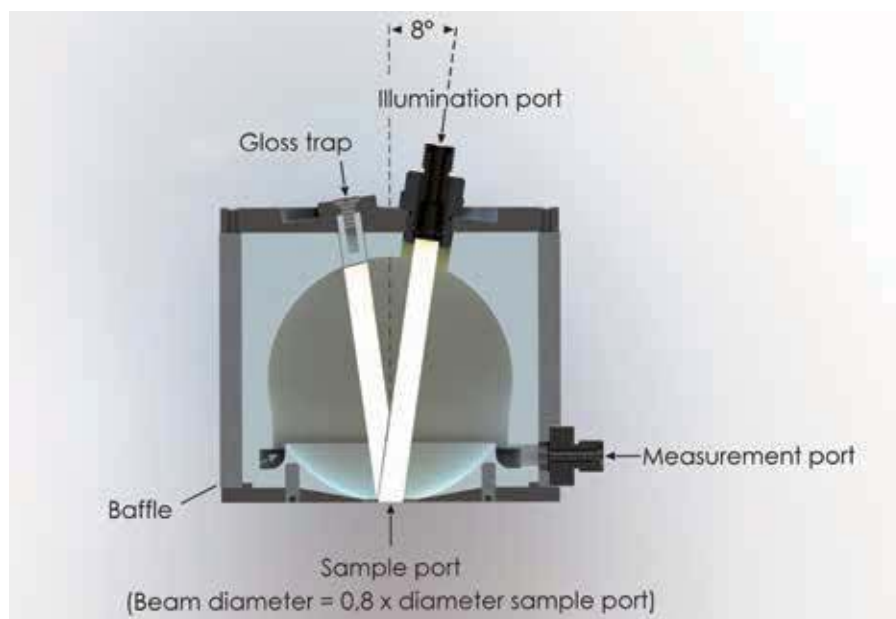

**Reflection Integrating Sphere**  
Drawing for AvaSphere-50-REFL or 80-REFL

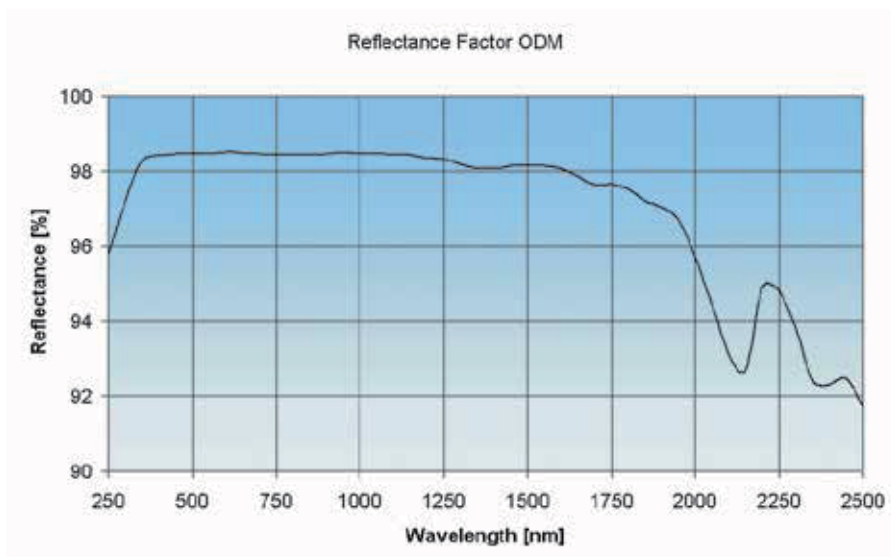

Reflection Curve AvaSphere

### Technical Data

|                                  | AvaSphere-30                     | AvaSphere-50                     | AvaSphere-80                    |
|----------------------------------|----------------------------------|----------------------------------|---------------------------------|
| <b>Internal diameter (mm)</b>    | 30                               | 50                               | 80                              |
| <b>Sample port diameter (mm)</b> | 6                                | 10                               | 15                              |
| <b>External Dimensions</b>       | 59.5 mm diameter<br>40 mm height | 69.5 mm diameter<br>60 mm height | 109 mm diameter<br>95 mm height |

### Ordering Information

|                             |  |
|-----------------------------|--|
| <b>AvaSphere-30-IRRAD</b>   | <ul style="list-style-type: none"> <li>Integrating Sphere 30 mm for light measurements (250-2500 nm), Sample-port 6 mm</li> </ul>  |
| <b>AvaSphere-50-IRRAD</b>   | <ul style="list-style-type: none"> <li>Integrating Sphere 50 mm, Sample-port 10 mm</li> </ul>  |
| <b>AvaSphere-80-IRRAD</b>   | <ul style="list-style-type: none"> <li>Integrating Sphere 80 mm, Sample-port 15 mm</li> </ul>  |
| <b>AvaSphere-30-REFL</b>    | <ul style="list-style-type: none"> <li>Integrating Sphere 30 mm for reflection (250-2500 nm), Sample-port 6 mm, 2 SMA port</li> </ul>  |
| <b>AvaSphere-50-REFL</b>    | <ul style="list-style-type: none"> <li>Integrating Sphere 50 mm for reflection, Sample-port 10 mm</li> </ul>   |
| <b>AvaSphere-80-REFL</b>    | <ul style="list-style-type: none"> <li>Integrating Sphere 80 mm for reflection, Sample-port 15 mm</li> </ul>   |
| <b>AvaSphere-50-LS-HAL</b>  | <ul style="list-style-type: none"> <li>Integrating Sphere 50 mm for reflection, built-in halogen light source, sample-port 10 mm</li> </ul>                                    |
| <b>AvaSphere-LED-ADR</b>    | <ul style="list-style-type: none"> <li>Cylindrical Adapter to hold 3, 5, 8 mm LED's inside the AvaSphere-50-IRRAD</li> </ul>   |
| <b>AvaSphere-LED-ADR-80</b> | <ul style="list-style-type: none"> <li>As AvaSphere-LED-ADR, but for AvaSphere-80-IRRAD</li> </ul>   |
| <b>AvaSphere-GT50</b>       | <ul style="list-style-type: none"> <li>Optional Gloss-trap for AvaSphere-50-REFL, coated with black absorbing material. Only in combination with AvaSphere-50-REFL.</li> </ul> |
| <b>AvaSphere-GT50-W</b>     | <ul style="list-style-type: none"> <li>Gloss-trap coated with white material to include specular reflection. Standard included in AvaSphere-50-REFL.</li> </ul>                |

# Integrating Sphere with internal halogen light source

## AvaSphere-50-LS-HAL-12V



Providing up to 160 times more light on your sample for a reflection measurement relative to our standard reflectance integrating sphere, the AvaSphere-50-LS-HAL-12V is a valuable instrument for reflection applications. It is a combination of an integrating sphere and a halogen light source. The sphere provides diffused halogen light on your sample without the losses associated with fiber-optic coupling. It has a direct collimated SMA-port for collection of the reflection signal with any of our AvaSpec spectrometers.

It's mostly useful for dark or low reflecting materials and NIR spectral measurements

where signal strength can be limited. It is also very useful for measuring gem stones. In the application section of this catalog a complete gemology setup can be found.

The AvaSphere-50-LS-HAL-12V has an internal diameter of 50 mm, a sample port of 10 mm and an SMA terminated reference port. The 5W halogen lamp is stabilized and cooled with forced airflow. A 12V power supply is included.

The switch line makes it possible to remotely switch the lightsource on/off with a TTL signal.

### Technical Data

|                             |                                |
|-----------------------------|--------------------------------|
| <b>Wavelength range</b>     | 360-2500 nm                    |
| <b>Internal diameter</b>    | 50 mm                          |
| <b>Sample port diameter</b> | 10 mm                          |
| <b>Color temperature</b>    | 2850 K                         |
| <b>Stability/Drift</b>      | < 0.1% / h                     |
| <b>Bulb life</b>            | 4.000 hrs                      |
| <b>Power requirement</b>    | 12VDC, 1A                      |
| <b>External Dimensions</b>  | 70 mm diameter, 82,5 mm height |

### Ordering Information

|                              |  |
|------------------------------|--|
| <b>AvaSphere-50-LS-HAL</b>   | • Integrating sphere 50 mm for reflection (360-2500 nm), including 5W halogen lightsource, sample port 10 mm diam., 2 SMA ports (reflection and reference) and 12V power supply. |
| <b>AvaLight-HAL-B-5W</b>     | • Replacement 5W halogen bulb for AvaSphere-50-LS-HAL-12V  |
| <b>IC-DB26-AvaSphere-0,5</b> | • Interface cable to control switchline with AvaSpec   |
| <b>AvaSphere-50-HOLD</b>     | • WS-2-GEM tile holder for AvaSphere-50-LS-HAL for gemology applications   |

**PHOTO  
TECHNICA**

www.phototechnica.co.jp

フォトテクニカ株式会社

〒336-0017 埼玉県さいたま市南区南浦和 1-2-17

TEL:048-871-0067 FAX:048-871-0068

e-mail:voc@phototechnica.co.jp

# Large Integrating Spheres

For measurement of high powered LEDs and sources, Avantes offers the AvaSphere-100, -150 and -200. The number corresponds with the internal diameter of the spheres in millimeters.

The 100, 150 and 200 models come with three ports: at 0, 90 degrees and NP. The port of your choice is fitted with a baffled SMA-905 connector, please specify when ordering. Either of the other two ports can be used for illumination or sampling. The default sample port sizes are typically 25% of the sphere's diameter. Port plugs or reducers are available on request.

All spheres can be attached to spectrometers via fiber-optic cables and the entire system can be irradiance calibrated to measure total flux of a lamp under test.

Special sizes on request.



## Technical Data

|                            | AvaSphere-100 | AvaSphere-150 | AvaSphere-200 |
|----------------------------|---------------|---------------|---------------|
| <b>Wavelength range</b>    | 400-1100 nm   |               |               |
| <b>Internal diameter</b>   | 102 mm        | 152 mm        | 203 mm        |
| <b>Port diameters</b>      | 25.4 mm       | 38.1 mm       | 50.8 mm       |
| <b>Port Reducers</b>       | 10 mm         |               |               |
| <b>External Dimensions</b> | 118 mm        | 168 mm        | 218 mm        |

## Ordering Information

|                           |  |
|---------------------------|--|
| <b>AvaSphere-100</b>      | • Integrating Sphere, 100 mm, 3 ports (0,90,NP), 1 baffled SMA port, incl. Postmount |
| <b>AvaSphere-100-SMA</b>  | • Additional SMA port for the AvaSphere-100  |
| <b>AvaSphere-100-PR10</b> | • Port reducer for the AvaSphere-100 to 10 mm  |
| <b>AvaSphere-100-PP</b>   | • Port plug for unused ports for the AvaSphere-100                                   |
| <b>AvaSphere-150</b>      | • Integrating Sphere, 150 mm, 3 ports (0,90,NP), 1 baffled SMA port, incl. Postmount |
| <b>AvaSphere-150-SMA</b>  | • Additional SMA port for the AvaSphere-150  |
| <b>AvaSphere-150-PR10</b> | • Port reducer for the AvaSphere-150 to 10 mm  |
| <b>AvaSphere-150-PP</b>   | • Port plug for unused ports for the AvaSphere-150                                   |
| <b>AvaSphere-200</b>      | • Integrating Sphere, 200 mm, 3 ports (0,90,NP), 1 baffled SMA port, incl. Postmount |
| <b>AvaSphere-200-SMA</b>  | • Additional SMA port for the AvaSphere-200  |
| <b>AvaSphere-200-PR10</b> | • Port reducer for the AvaSphere-200 to 10 mm  |
| <b>AvaSphere-200-PP</b>   | • Port plug for unused ports for the AvaSphere-200                                   |

**PHOTO  
TECHNICA**

[www.phototechnica.co.jp](http://www.phototechnica.co.jp)

フォトテクニカ株式会社

〒336-0017 埼玉県さいたま市南区南浦和 1-2-17

TEL: 048-871-0067 FAX: 048-871-0068

e-mail: [voc@phototechnica.co.jp](mailto:voc@phototechnica.co.jp)

For the latest information,  
go to [www.avantes.com](http://www.avantes.com)