

Mini Autocorrelator

Compact Autocorrelator

Mini is the perfect pulse width measurement tool in a compact size and with high sensitivity.

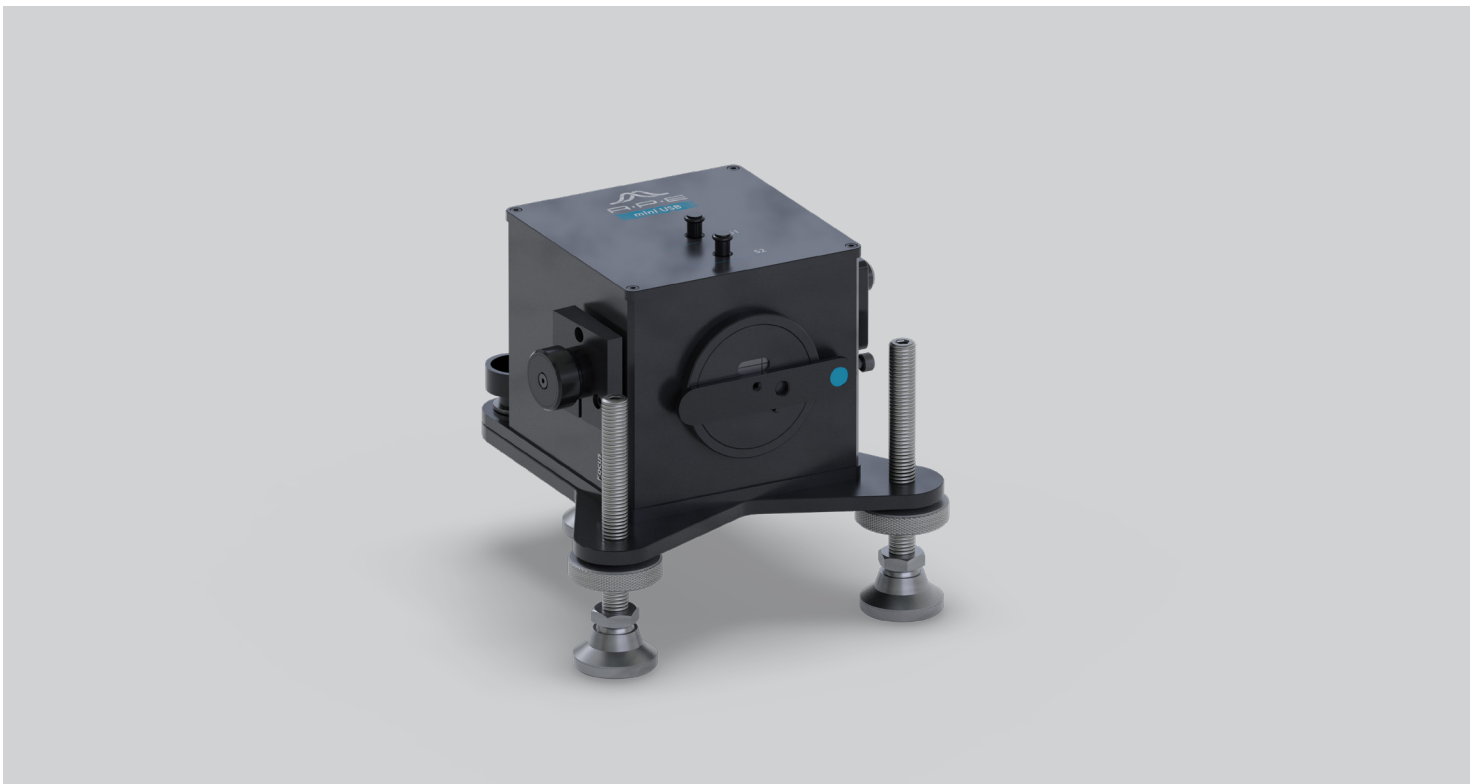

- Wavelength coverage from 250 nm to 3200 nm
- Compact design for minimum space requirements and easy portability
- UV measurements without cross-correlation
- Ultra-precise delay resolution
- Interferometric and intensity autocorrelation (Mini PD) or interferometric and hybrid intensity autocorrelation (Mini TPA)
- Gaussian, Sech^2 , and Lorentzian fitting routines
- Including software and USB interface
- TCP/IP remote control with standardized command set for easy programming
- NIST traceable calibration
- Stable protective carrying case

Mini for Routine Tasks

Two models available

Mini TPA - Exchangable detectors

The APE Mini TPA benefits from the two-photon absorption principle. This eliminates the need of SHG crystal angle tuning and makes the wavelength tuning process unnecessary. Various exchangeable Optics Sets to cover a wide wavelength range are available for the Mini TPA.

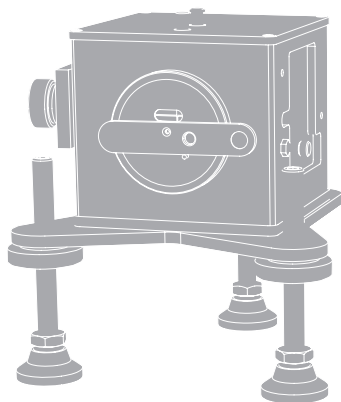
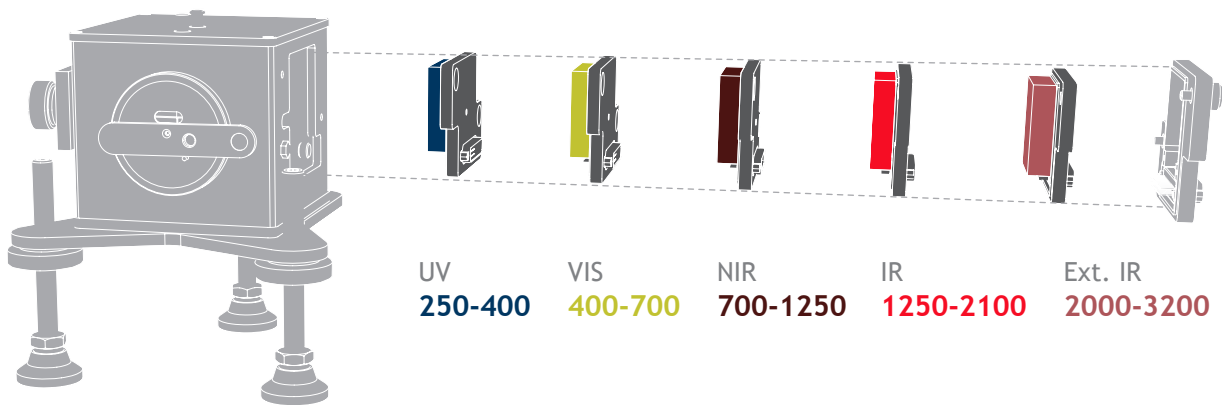

Mini PD - Detector not exchangable

The Mini-PD NIR is specifically designed for measurements in the NIR range. Unlike the Mini-TPA, its detector cannot be changed. The key advantage of this device is that by utilizing a photodiode PD for measurement and focusing solely on the NIR range, it delivers optimal measurement performance at a highly cost-effective price.

NIR
700-1200

UV Range without Cross-Correlation

Together with an UV Optics Sets, the Mini TPA provides pulse width measurements in the UV range, from 250 nm to 400 nm – without the need for cross-correlation. Elimination of the cross-correlation approach makes the data evaluation easier, by reducing the conventional two-step measurement process to a one-step approach.

Mini Specifications

Mini	TPA	PD
Pulse width	35 fs ... 3.5 ps	50 fs ... 3.5 ps
Wavelength range	250 nm ... 3200 nm depending on Optics Set	700 nm ... 1200 nm
Recommended repetition rate	>300 Hz	>300 Hz
Sensitivity*, typical	0.1 W ² depending on Optics Set For UV only: <500 W ²	1 W ² depending on Optics Set
Max. input power, pulse energy	0.5 W for quasi-cw laser 5 μJ for kHz laser	
Input beam polarization	Linear, any	Linear, horizontal
Input beam coupling	Free-space with 6 mm aperture fiber coupling (FC/PC or FC/APC) optional	
Input beam height	86 mm ... 150 mm or 50 mm optional	
Measurement refresh rate	10 Hz	
Delay resolution	1 femtosecond	
Type of measurement mode	Collinear intensity	Non-collinear intensity and collinear interferometric - switchable
Available detector types	Two-Photon Absorption (TPA) exchangeable	Photodiode (PD) with fixed wavelength range
Calibration	NIST traceable calibration certificate included	
Trigger mode	300 Hz ... 50 kHz	
Phase matching	not required	Software-supported
Intensity resolution	16 bit	
Connectivity	USB, TCP/IP (SCPI command set)	
Remote control	Programmable via API	

* The sensitivity can be calculated as $(P_{\text{average}} * P_{\text{peak}}) = (P_{\text{average}}^2 / (f_{\text{rep.rate}} * \tau_{\text{pulse duration}})) = W^2$. The resulting value of W^2 must be higher than the specification.

Note: Sensitivity gives an approximation within an order of magnitude as it doesn't take into account other factors such as beam parameters and pulse quality.

Appendix Technical Drawings

All dimensions in mm

Mini

- Compact autocorrelator

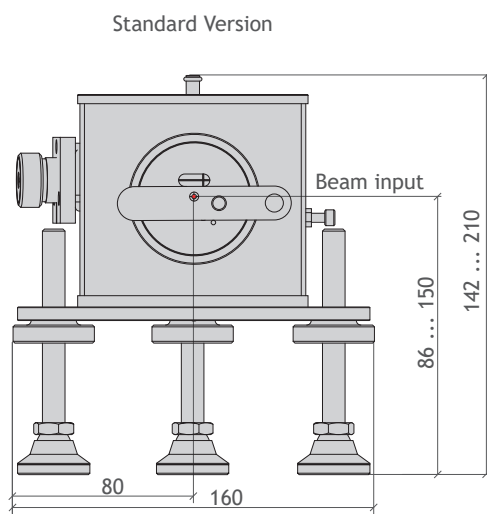

Optional Reduced Beam Input Height Version

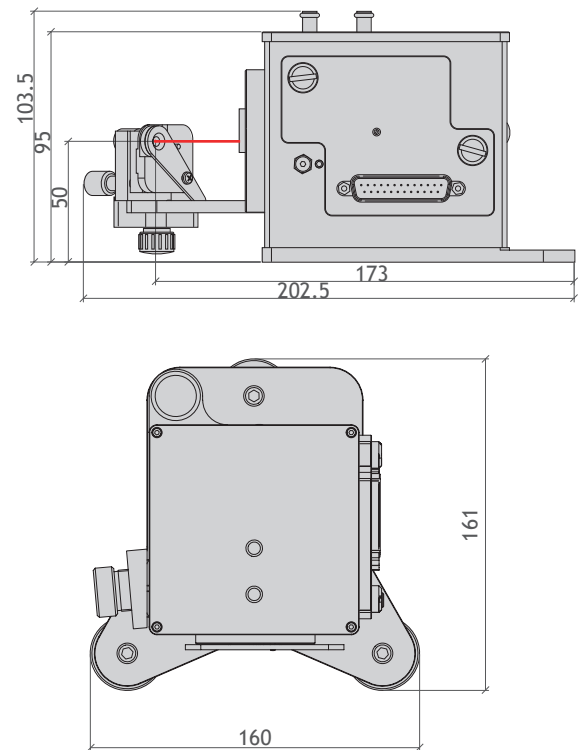

Contact

APE Angewandte Physik & Elektronik GmbH
 Plauener Str. 163-165 | Haus N | 13053 Berlin | Germany
 T: +49 30 986 011-30 F: +49 30 986 011-333
 E: sales@ape-berlin.de www.ape-berlin.de

**PHOTO
TECHNICA** フォトテクニカ株式会社
www.phototechnica.co.jp
 〒336-0017 埼玉県さいたま市南区南浦和 2-18-2
 TEL:048-871-0067 FAX:048-871-0068
 e-mail:voc@phototechnica.co.jp