

Carpe Autocorrelator for Microscopy & Lithography

Microscopy & Lithography Autocorrelator

APE's Carpe autocorrelator is designed to measure the pulse width of laser pulses directly at the sample location in a focus. It is therefore ideally suited for use in microscopy or lithography.

The Carpe autocorrelator measures the pulse width both at the sample location (e.g. behind the microscope optics) and at any other location between laser and sample. A comparison of the pulse widths obtained at these two locations allows the pulse broadening to be calculated and / or the pulse width to be optimized with a pre-chirper.

An additional power measurement (optional) at the sample location also supports systematic and quantitative studies on the laser power of ultrashort pulses.

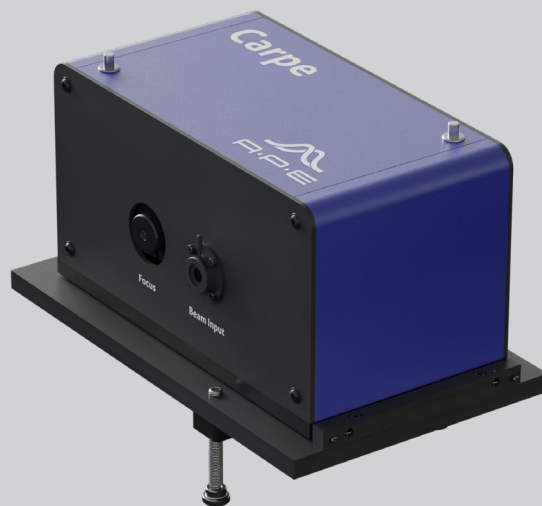

- Measure pulse widths at the sample position and before microscope input
- Measure average power at sample position (optional)
- Estimate the peak power in conjunction with the pulse width
- Option: short working distance, e.g. for immersion objective lenses
- Option: pre-chirper femtoControl for pulse compression & dispersion compensation

Carpe Specifications

Carpe	VIS	NIR	IR
Pulse width	30 fs ... 3.5 ps		
Wavelength range	420 nm ... 700 nm	700 nm ... 1250 nm	1250 nm ... 2000 nm
Recommended repetition rate	>100 kHz		
Sensitivity*, typical	1 W ²		
Max. input power, pulse energy	0.5 W for quasi-cw laser 5 μJ for kHz laser		
Input beam polarization	Linear, horizontal		
Input beam coupling	Free-space with 6 mm aperture		
Input beam height	94 mm ... 127 mm		
Measurement refresh rate	10 Hz		
Delay resolution	1 femtosecond		
Type of measurement mode	Collinear intensity		
Available detector types	Internal sensor: Two-Photon Absorption (TPA) External sensor: TPA exchangeable		
External AC sensor	Measures pulse width at sample location, included for same wavelength range as internal detector, additional external sensors for other wavelength ranges are available and can be used with same base unit.		
External power sensor, optional	Measures power at sample location, wavelength range: 700 nm ... 1050 nm, up to 300 mW		
Working distance	>0.5 mm or <0.5 mm optional e.g. immersion lenses		
Calibration	NIST traceable calibration certificate included		
Intensity resolution	16 bit		
Connectivity	USB, TCP/IP (SCPI command set)		
Remote control	Programmable via API		

* The sensitivity can be calculated as $(P_{\text{average}} * P_{\text{peak}}) = (P_{\text{average}}^2 / (f_{\text{rep.rate}} * \tau_{\text{pulse duration}})) = W^2$. The resulting value of W^2 must be higher than the specification. Note: Sensitivity gives an approximation within an order of magnitude as it doesn't take into account other factors such as beam parameters and pulse quality.

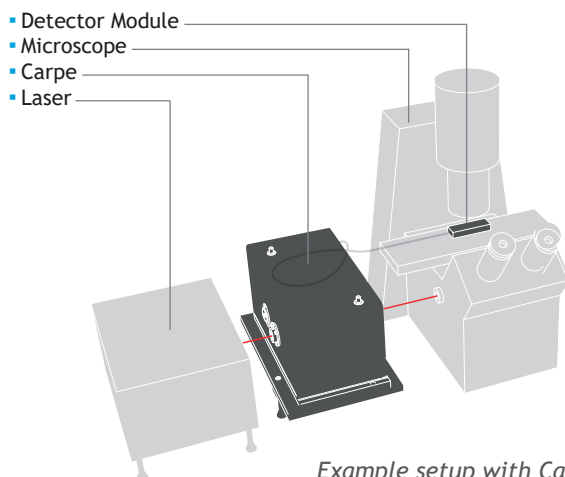

Example setup with Carpe autocorrelator

Appendix Technical Drawings

Carpe

- First choice for multiphoton microscopy

page 19

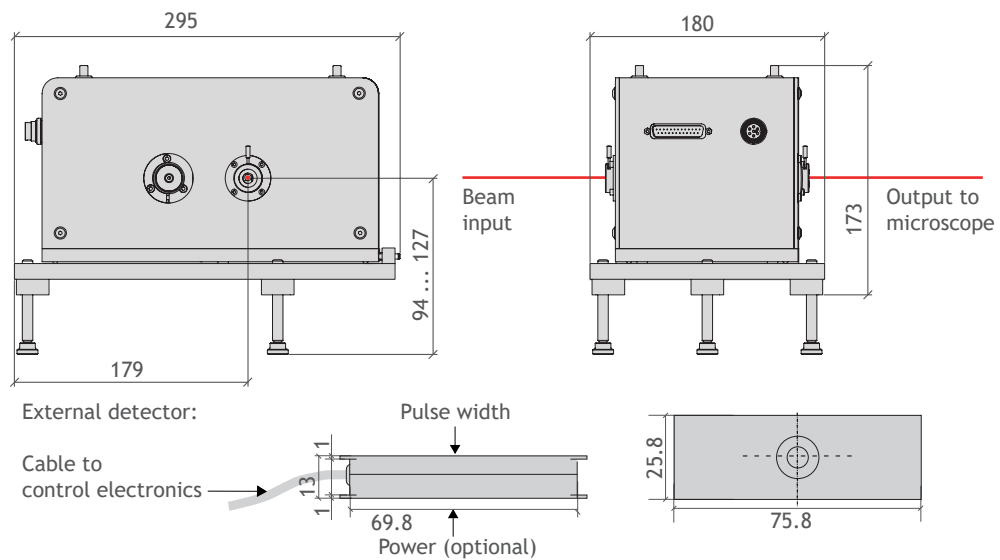

Contact

APE Angewandte Physik & Elektronik GmbH
Plauener Str. 163-165 | Haus N | 13053 Berlin | Germany
T: +49 30 986 011-30
F: +49 30 986 011-333
E: sales@ape-berlin.de
www.ape-berlin.de

APE follows a policy of continued product improvement.
Therefore, specifications are subject to change without notice.

© APE GmbH | Rev. 4.2.1

**PHOTO
TECHNICA** www.phototechnica.co.jp
フォトテクニカ株式会社
〒336-0017 埼玉県さいたま市南区南浦和 2-18-2
TEL:048-871-0067 FAX:048-871-0068
e-mail:voc@phototechnica.co.jp