

pulseCheck NX Modular Autocorrelator

Pulse Measurement Perfection with the Multitalent from APE

The pulseCheck platform grows with your tasks. Suitable for characterizing virtually all ultrafast pulsed lasers, APE's pulseCheck NX autocorrelator covers a wide range of wavelengths and pulse widths. This flexibility is achieved by using interchangeable Optics Sets, typically consisting of a nonlinear crystal and a dedicated detector module.



- Exchangeable Optics Sets for wavelength coverage from 200 nm to 12 μm
- Wide range of sensitivity levels covered with PMT, PD, and TPA
- High temporal resolution with a sampling resolution down to 50 attoseconds
- Toggle between interferometric and intensity autocorrelation
- Integrated controller for data acquisition, data fitting, and fast FPGA data processing
- Software supported wavelength tuning of crystal (phase matching)
- Fully compliant with DIN 58175-2:2021-04 (autocorrelation measurement methods)
- NX-Software and USB as well as Ethernet connection
- TCP/IP remote control with standardized command set for easy programming
- Option: FROG for complete pulse characterization

pulseCheck NX Overview

pulseCheck	NX 50	NX 150	SM 2000
Pulse width	5 fs ... 15 ps	10 fs ... 40 ps	20 fs ... 500 ps
Wavelength range	200 nm ... 12 μm depending on Optics Set		
Recommended repetition rate	PD, TPA: >10 Hz, PMT: >250 kHz		
Sensitivity*, typical	1 W ² ... 10 ⁻⁶ W ² depending on Optics Set		
Max. input power, energy	0.5 W for quasi-cw laser 5 μJ for kHz laser		
Input beam polarization	Linear, horizontal polarization rotator optional		
Input beam coupling	Free-space with 6 mm aperture fiber coupling (FC/PC or FC/APC) optional		
Input beam height	76 mm		
Measurement refresh rate	10 Hz	7.5 Hz	120 ps/sec
Delay resolution	50 attoseconds	200 attoseconds	1 femtosecond
Contrast	10 ⁻⁴		
Type of measurement mode	PMT, PD: non-collinear intensity and collinear interferometric - switchable TPA: hybrid collinear intensity		
Available detector types	Exchangeable: Photomultiplier (PMT), Photodiode (PD) and Two-Photon Absorption (TPA)		
Calibration	NIST traceable calibration certificate included		
Electronics	Completely intergrated and self-sustained		
Trigger mode	TTL <50 kHz		TTL <10 kHz
Phase matching	Automatic		Software-supported
Intensity resolution	18 bit		
Connectivity	Ethernet, USB, TCP/IP (SCPI command set)		
Remote control	Programmable via API		

* The sensitivity can be calculated as $(P_{\text{average}} * P_{\text{peak}}) = (P_{\text{average}}^2 / (f_{\text{rep.rate}} * \tau_{\text{pulse duration}})) = W^2$. The resulting value of W^2 must be higher than the specification.

Note: Sensitivity gives an approximation within an order of magnitude as it doesn't take into account other factors such as beam parameters and pulse quality.

... Flexibility for your Experiments

High Resolution & Strong Processing Performance

The advanced system-on-chip based architecture enables measurements with low latency, a high temporal resolution down to 50 attoseconds and an intensity dynamic range of 18 bit. This allows full access to even the tiniest autocorrelation features.

Maximum Functionality through Modular Design

APE meets the growing need for maximum functionality and flexibility with the modular concept on which the pulseCheck NX autocorrelator series is based. Thus, Optics Sets to upgrade the wavelength range or FROG capability can be added at any time.

From Ultrashort to Long Pulses

Various pulseCheck NX configurations can be adapted to the individual needs of pulse width measurements. The measurement of extra long pulse widths up to 500 ps is possible with pulseCheck SM.

- pulseCheck NX 50
- pulseCheck NX 150
- pulseCheck SM 2000

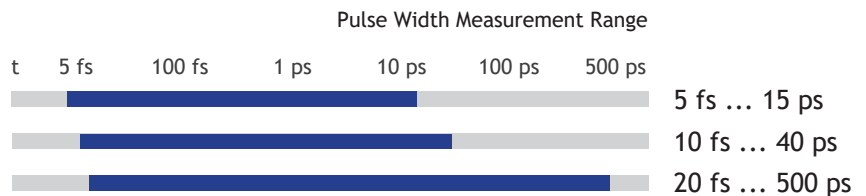

High Sensitivity and Low Noise with Three Types of Detectors

- Photodiode Detector (PD)
- Photomultiplier (PMT)
- Two-Photon Absorption (TPA)

Standard sensitivity up to 1 W^2
 Highest sensitivity up to 10^{-6} W^2
 High sensitivity up to 10^{-2} W^2

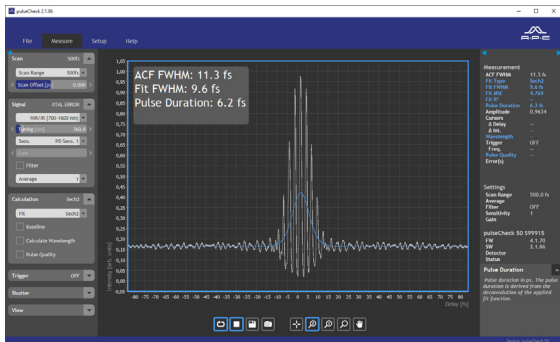

Software GUI for pulseCheck NX



pulseCheck NX

Optics Sets

A variety of different and exchangeable Optics Sets cover a wide wavelength range: from UV at 200 nm to Mid-IR at 12 μm .

Photodiode (PD)

- **Typ. Sensitivity:** 1 W^2 ▪ **Rep. Rate:** $> 10 \text{ Hz}$ ▪ **Measurement Mode:** Collinear and Noncollinear

$\lambda[\text{nm}]$

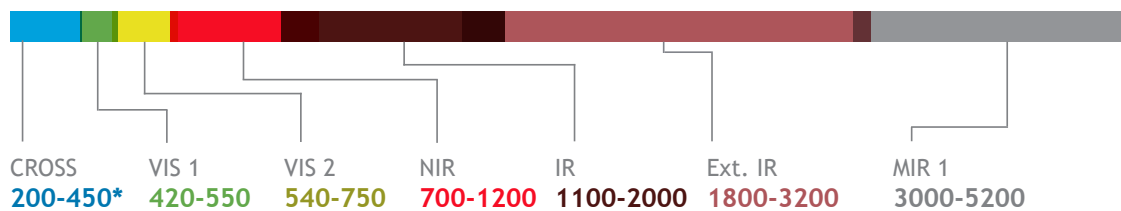

Photomultiplier (PMT)

- **Typ. Sensitivity:** up to 10^{-6} W^2 ▪ **Rep. Rate:** $> 250 \text{ kHz}$ ▪ **Measurement Mode:** Collinear and Noncollinear

$\lambda[\text{nm}]$

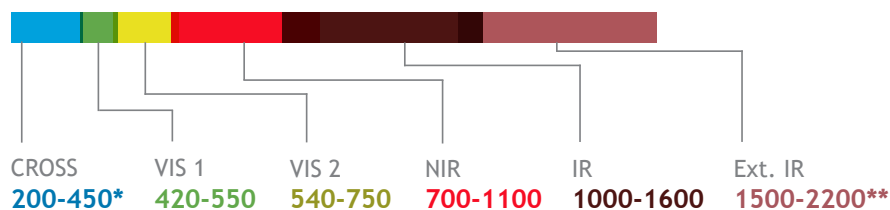

Two Photon Absorption (TPA)

- **Typ. Sensitivity:** $< 0.1 \text{ W}^2$ (NIR/IR) ▪ $< 1 \text{ W}^2$ (VIS) ▪ $< 100 \text{ W}^2$ (UV) ▪ **Rep. Rate:** $> 10 \text{ Hz}$ ▪ **Measurement Mode:** Collinear Intensity

$\lambda[\text{nm}]$

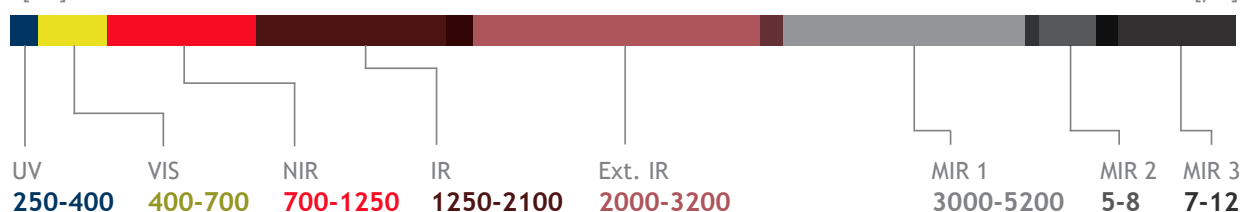

* For cross-correlation: Actual wavelength range to be defined according to customer's specifications.

** For the wavelength range 1500 ... 2200 nm we recommend to use the highly sensitive IR detector "Extended IR PD SELECTED"

pulseCheck SM 2000

Long-Range Autocorrelator

Pulse Width Measurement up to 500 ps

With the revised version of the long-range delay technology in pulseCheck SM, the new autocorrelator offers a scanning range up to three times larger and a measuring speed up to five times faster than the previous long-range models. The pulseCheck SM includes a high performance controller that is integrated into the device.

The pulseCheck SM is suitable for particularly long pulse widths of up to 500 ps. At the other end, short pulses down to 20 fs widths can be measured. A resolution of 1 fs and a sampling rate of 1 MHz is available over the entire measurement range.

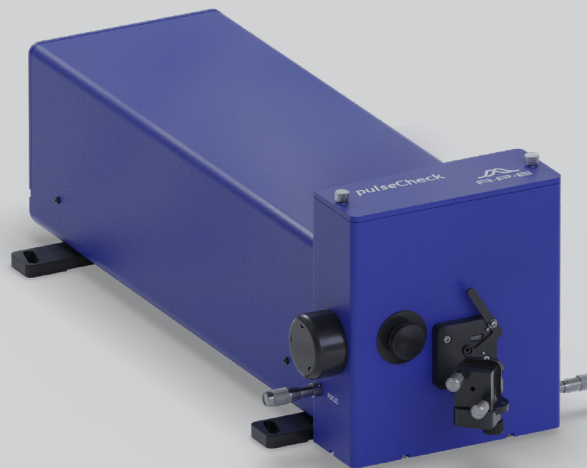

- Pulse widths from 20 fs up to 500 ps
- Optics Sets from 200 nm to 12 μm
- Measurement speed of 120 ps/sec
- Integrated high performance controller
- Toggle between interferometric and intensity autocorrelation
- Wide range of sensitivity levels covered with PMT, PD, and TPA
- USB & Ethernet connectivity and TCP/IP remote control
- Gaussian, Sech^2 , and Lorentzian fitting routines
- NIST traceable calibration

Appendix Technical Drawings

All dimensions in mm

pulseCheck NX

- Multitalent for any task

page 6

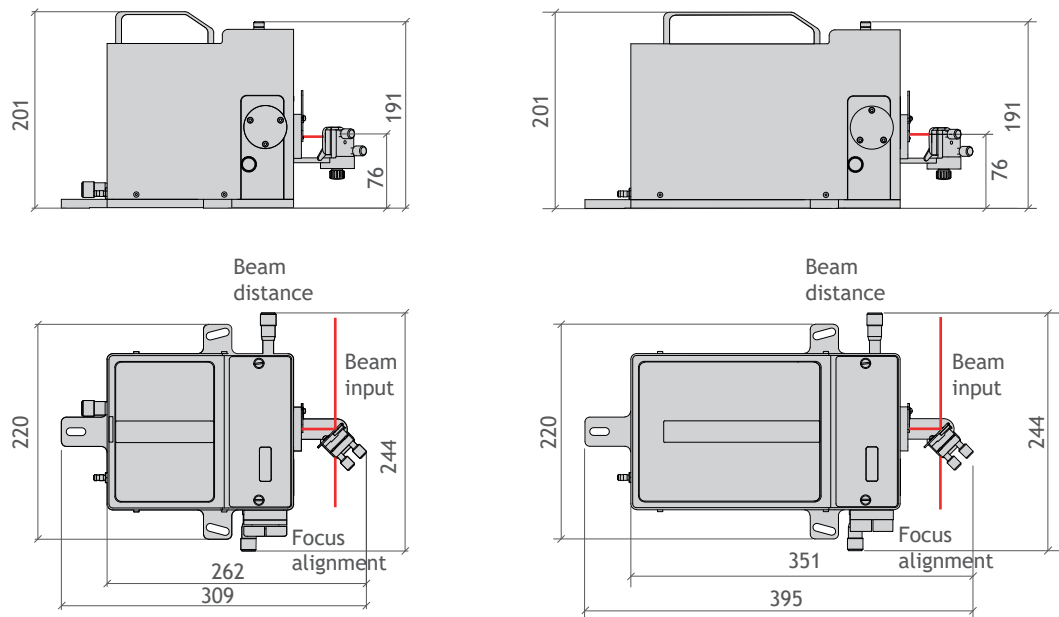

pulseCheck SM 2000 & Type 2

- Long-range autocorrelator SM 2000

page 13

- Type 2

page 14

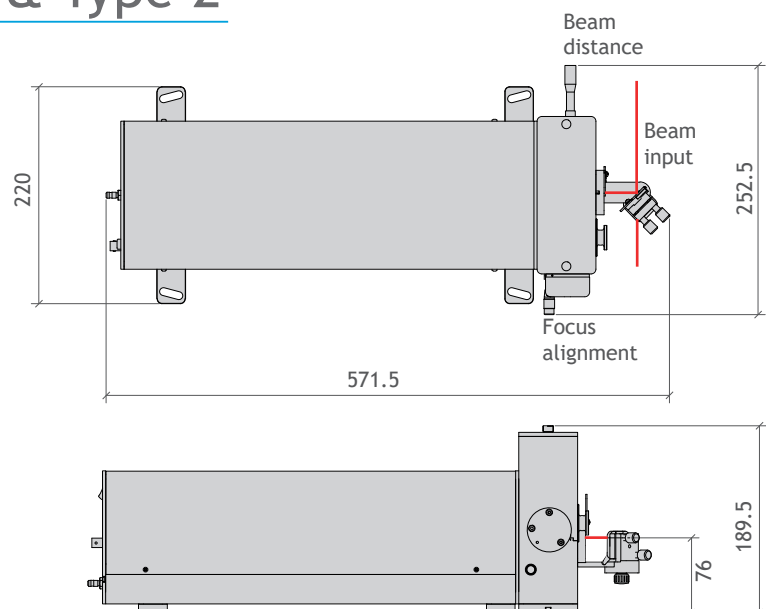



Contact

APE Angewandte Physik & Elektronik GmbH
Plauener Str. 163-165 | Haus N | 13053 Berlin | Germany
T: +49 30 986 011-30
F: +49 30 986 011-333
E: sales@ape-berlin.de
www.ape-berlin.de

APE follows a policy of continued product improvement.
Therefore, specifications are subject to change without notice.

© APE GmbH | Rev. 4.3.1

**PHOTO
TECHNICA** www.phototechnica.co.jp
フォトテクニカ株式会社
〒336-0017 埼玉県さいたま市南区南浦和 2-18-2
TEL:048-871-0067 FAX:048-871-0068
e-mail:voc@phototechnica.co.jp