

HARPIA | TB

Third Beam Delivery Module

FEATURES

- Delivery of an additional femtosecond or picosecond beam
- Polarization, intensity, and delay control
- Femtosecond stimulated Raman scattering (FSRS) support
- Z-scan support



The HARPIA-TB is a third beam delivery module for the HARPIA-TA unit that adds an additional dimension to time-resolved absorption measurements. It allows multi-pulse time-resolved spectroscopic techniques, in which the ongoing pump-probe photodynamics are perturbed by a delayed third pulse.

In conjunction with a narrow-bandwidth picosecond pulse source, HARPIA-TB can be used to perform femtosecond stimulated Raman scattering (FSRS) measurements. Furthermore, HARPIA-TB supports Z-scan measurements.

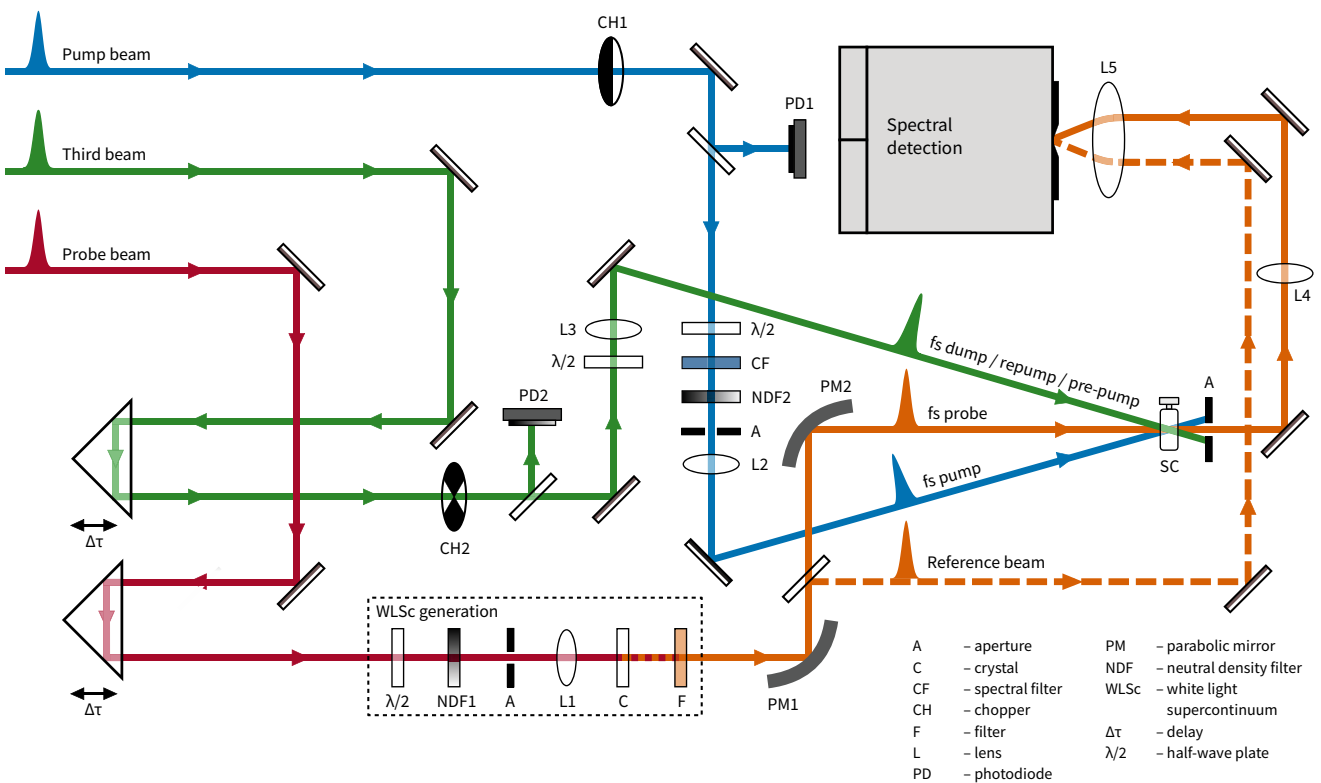

HARPIA optical layout for multi-pulse experiments

SPECIFICATIONS

Model	HARPIA-TB
Delay range ¹⁾	2 ns, 4 ns
Delay resolution	2.1 fs, 4.2 fs

DIMENSIONS

Physical dimensions (L × W × H)	670 × 250 × 183 mm
---------------------------------	--------------------

¹⁾ 8 ns delay range is available on request; contact sales@lightcon.com for details.

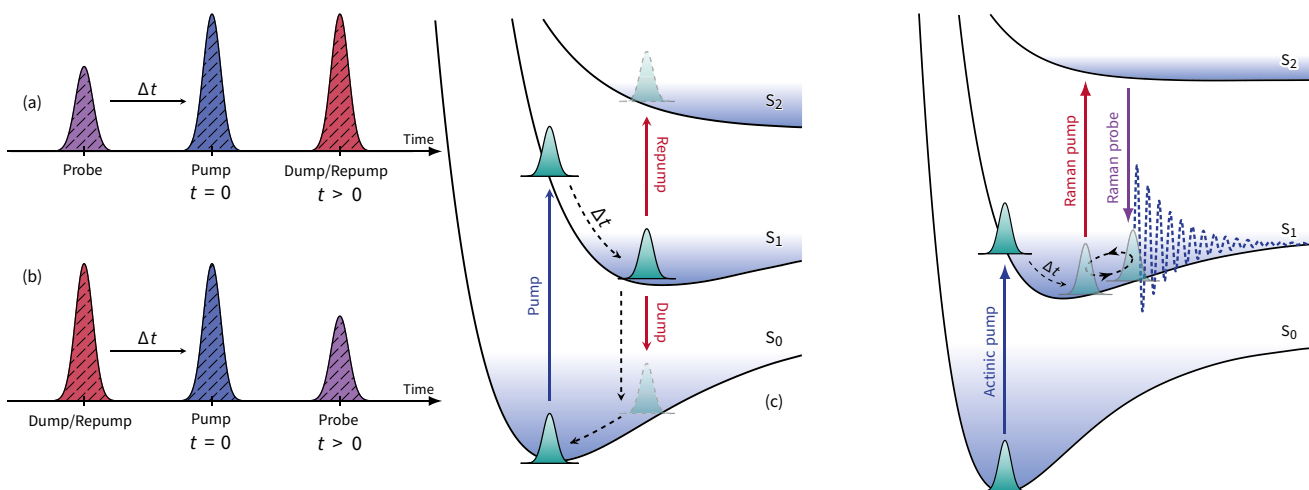
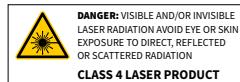

State transitions and pulse timing in multi-pulse time-resolved transient absorption spectroscopy

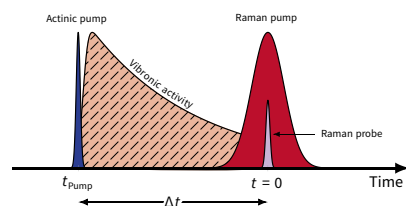

Femtosecond stimulated Raman scattering (FSRS)

DRAWINGS

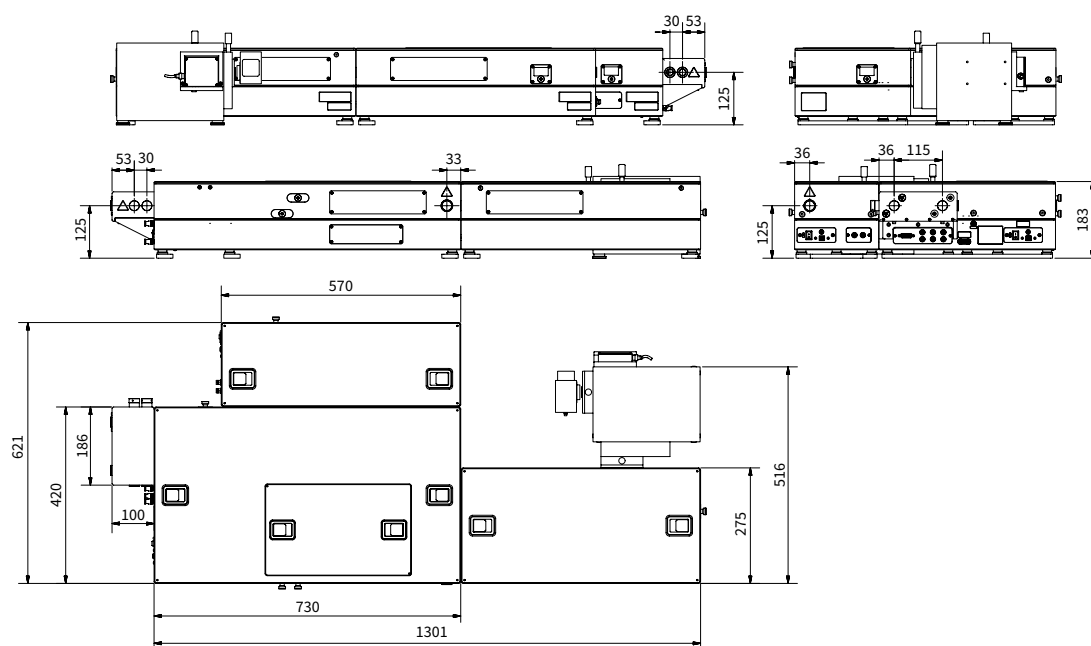

Drawings of HARPIA system with HARPIA-TB and HARPIA-TF modules