

HARPIA | TF

Femtosecond Fluorescence Upconversion and TCSPC Module

FEATURES

- Femtosecond-to-microsecond measurements
- Automated switching between fluorescence upconversion and TCSPC
- Automated spectral scanning and calibration
- Optional operation as a stand-alone unit



The HARPIA-TF is a time-resolved fluorescence measurement module that combines fluorescence upconversion and TCSPC techniques. In fluorescence upconversion, the signal from the sample is mixed in a nonlinear crystal with a gating femtosecond pulse to achieve high temporal resolution, which is limited by the duration of the gate and pump pulses. For fluorescence decay times in the nanosecond to microsecond range, the instrument can be used in time-correlated

single-photon counting (TCSPC) mode to measure kinetic traces up to 5 μ s. The combination of the two methods enables the measurement of spectrally-resolved fluorescence decay in the femtosecond to microsecond range. Using a high repetition rate PHAROS or CARBIDE laser, the fluorescence dynamics can be measured while exciting the samples with pulse energies down to several nanojoules.

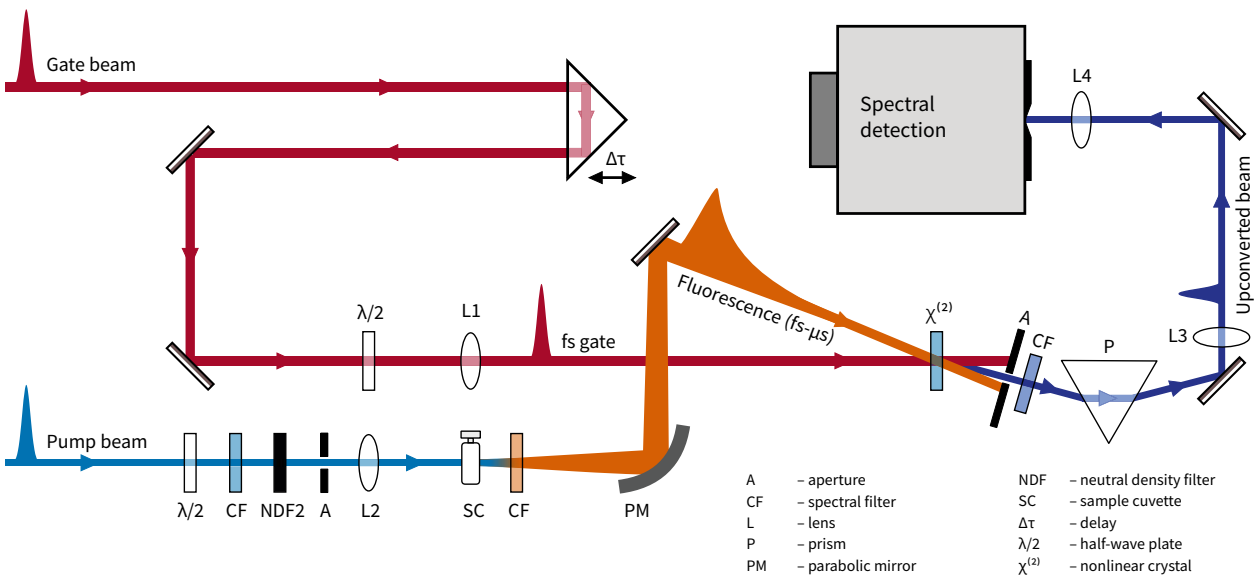

HARPIA optical layout for fluorescence upconversion measurements

SPECIFICATIONS

Model	HARPIA-TF
-------	------------------

UPCONVERSION MODE

Spectral range ¹⁾	300 – 1600 nm
Spectral resolution ²⁾	~ 100 cm ⁻¹
Delay range	2 ns / 4 ns / 8 ns
Delay resolution	2.1 fs / 4.2 fs / 8.3 fs
Temporal resolution	< 1.4× pump or gate pulse duration, whichever is longer
SNR ³⁾	65 : 1

TCSPC MODE

Spectral range ⁴⁾	320 – 820 nm	
TCSPC detector ⁵⁾	Standard	High-speed
Temporal resolution	< 180 ps	< 50 ps
Maximum measurement range ⁶⁾	5 μs	
SNR ⁷⁾	100 : 1	

DIMENSIONS

Physical dimensions (L × W × H) ⁸⁾	571 × 275 × 183 mm
---	--------------------

- ¹⁾ Depends on the gating source, full range covered with different nonlinear crystals.
- ²⁾ Limited by the spectral bandwidth of the gating pulse.
- ³⁾ Estimated as the standard deviation of a set of 100 points at 50 ps intervals measured in Rhodamine 6G dye at an unconverted wavelength of 360 nm using a PHAROS laser running at 150 kHz repetition rate; assuming 0.5 s averaging per point. Not applicable to all samples and configurations.
- ⁴⁾ Spectral range is extendable to NIR; contact sales@lightcon.com for details.
- ⁵⁾ Different models available; contact sales@lightcon.com for details.

- ⁶⁾ Maximum measurement range can be extended with a phosphorescence upgrade.
- ⁷⁾ Estimated by fitting a kinetic trace measured in Rhodamine 6G solution at 580 nm with multiple exponents, subtracting the fit from the data and taking the ratio between the standard deviation of the residuals and the 0.5× maximum signal value, at 250 kHz repetition rate; assuming 5 s averaging per trace. Not applicable to all samples and configurations.
- ⁸⁾ Without external spectrograph.

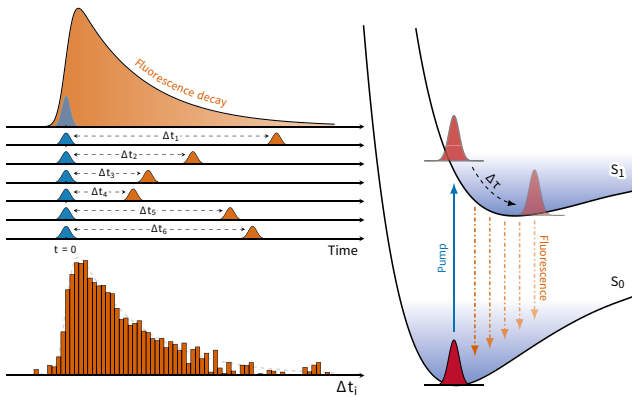
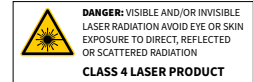

Principle of time-correlated single-photon counting (TCSPC)

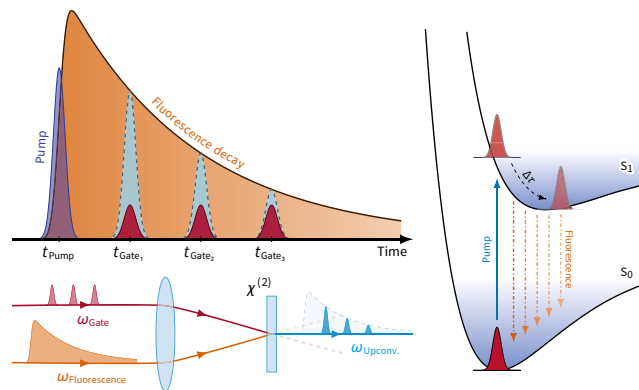

Principle of time-resolved fluorescence upconversion