

HARPIA | TA

Ultrafast Transient Absorption Spectrometer

APPLICATION FIELDS

- Photochemistry
- Photobiology
- Photophysics
- Material science
- Semiconductor physics
- Time-resolved spectroscopy



The HARPIA-TA ultrafast transient absorption spectrometer features market-leading characteristics such as 0.05 mOD ($10^{-4} \Delta T/T$) sensitivity and the ability to work at high repetition rates up to 1 MHz, when used with a PHAROS or a CARBIDE laser and an ORPHEUS OPA. A high repetition rate allows measuring transient absorption dynamics, while exciting the samples with low pulse energies down to several nanojoules. Several probe configurations and detection options are available: from simple and cost-effective photodiodes for single-wavelength detection, to white-light supercontinuum probing, combined with spectrally-resolved broadband detection. HARPIA-TA features integrated data acquisition and measurement control electronics providing advanced features such as:

- Single (sample-only) or multiple (sample and reference) integrated spectral detectors
- Simple integration of an external spectrograph
- Automated pump and probe beam position tracking and alignment
- Straightforward switching between transient absorption and transient reflection measurements

Several delay line options are available to cover delay ranges from 2 ns to 8 ns using either linear leadscrew (20 mm/s) or fast ball-screw (300 mm/s) translation stages.

Various optomechanical peripherals and electronics are integrated in HARPIA including:

- Optical chopper which can be synchronized to an external trigger
- Motorized Berek polarization compensator to adjust the polarization of the pump beam
- Motorized translating supercontinuum generator (for use with CaF_2 or MgF_2)
- Automated sample mover to translate the sample in the focal plane, thus avoiding local sample overexposure
- Integrated computer and data acquisition electronics
- Sample stirrer
- Beam profiler

HARPIA-TA is compatible with many cryostats and peristaltic pumps. The capabilities of the spectrometer can be further extended using expansion modules.

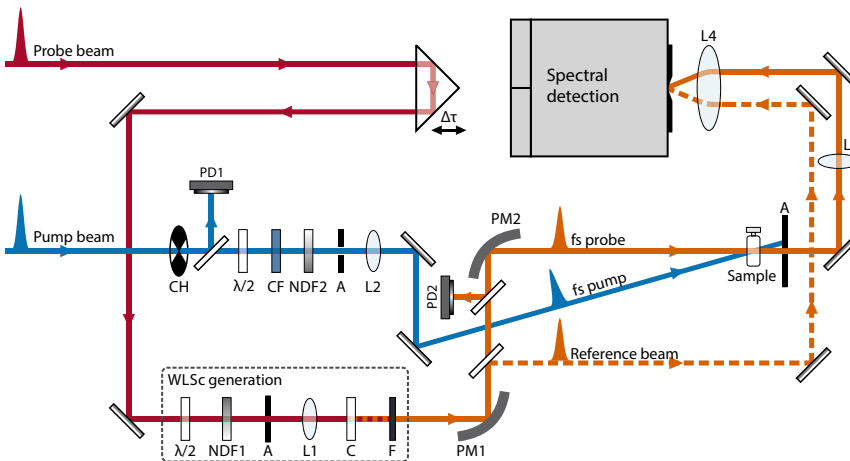

HARPIA-TA optical layout for pump-probe experiments

SPECIFICATIONS

Probe wavelength range, white light supercontinuum generator pumped by 1030 nm	480 – 1100 nm
Probe wavelength range, white light supercontinuum generator pumped by 515 nm	350 – 750 nm
Probe wavelength range, white light supercontinuum generator pumped by 800 nm	350 – 1100 nm
Spectral range of multichannel detectors	200 – 1100 nm, 700 – 1800 nm or 1.2 – 2.6 μm
Spectral range of single-channel detectors	180 nm – 24 μm
Delay range	4 ns, 6 ns or 8 ns
Delay resolution	4.2 fs, 6.3 fs or 8.3 fs
Laser repetition rate	1 – 1000 kHz
Time resolution	<1.4x of pump or probe pulse duration, whichever is longer
Physical dimensions, L×W×H	730 × 420 × 160 mm ¹⁾
Sample chamber area	205 × 215 mm

¹⁾ Without external spectrograph.

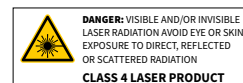

Custom cryostat mounting option

OUTLINE DRAWINGS

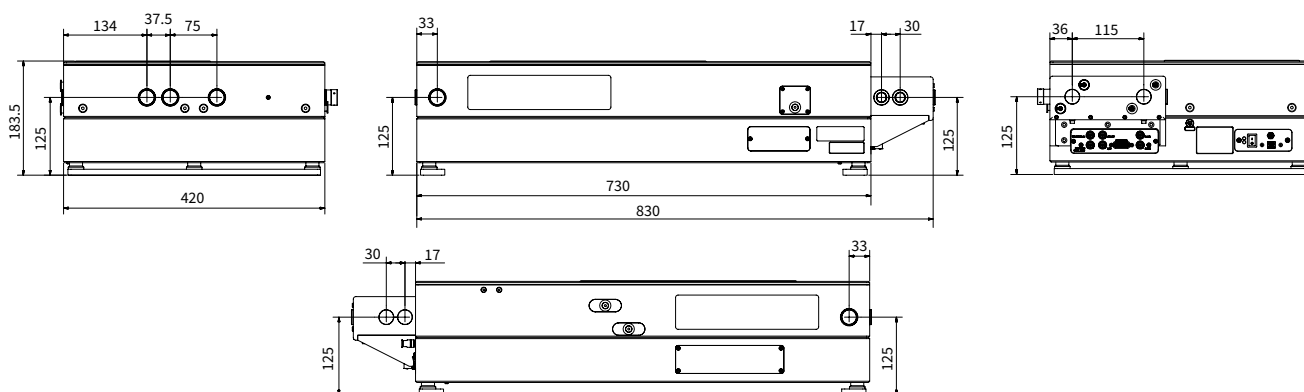

HARPIA-TA outline drawings

www.phototechnica.co.jp
フォトテクニカ株式会社
 〒336-0017 埼玉県さいたま市南区南浦和 1-2-17
 TEL:048-871-0067 FAX:048-871-0068
 e-mail: voc@phototechnica.co.jp