

HIRO

Harmonics Generator



FEATURES

- 515 nm, 343 nm, 257 nm
- Easy switching between active harmonic
- Simultaneous outputs available
- Integrated separation of the harmonics
- Flexible in fixing and easily customized to include additional options (continuum generators, beam expanders down-collimators)

HIRO is a valuable option for PHAROS lasers and FLINT oscillators that provides high power harmonics radiation at 515 nm, 343 nm and 258 nm wavelengths. We offer several standard HIRO models (with open prospect of future upgrades) which meet most users' needs. The active harmonic is selected by manual rotation of the knob – changing the harmonics will never take longer than a few seconds thanks to its unique layout and housing construction.

HIRO is the most customizable and upgradable harmonics generator available on the market. It can be easily modified to provide white light continuum, beam splitting/expanding/down-collimating options integrated in the same housing as well as harmonics splitting that makes all three harmonics available at a time.

Please contact Light Conversion for customized version of HIRO.

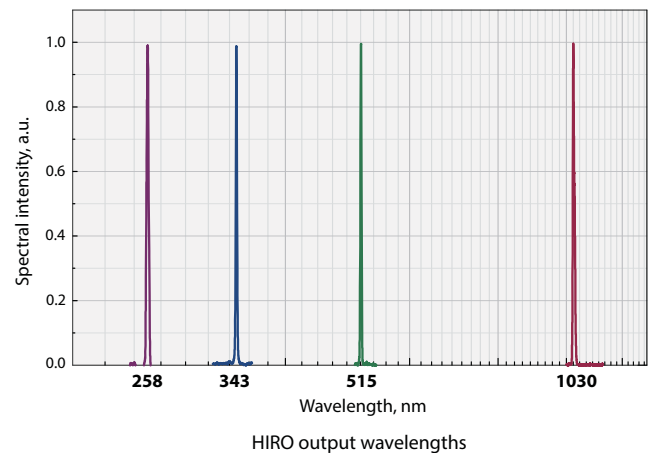

HIRO MODELS

Product name	Generated harmonics	Output wavelengths
PH1F1	2H	515 nm
PH1F2	2H, 4H	515 nm, 258 nm
PH1F3	2H, 3H	515 nm, 343 nm
PH1F4	2H, 3H, 4H	515 nm, 343 nm, 258 nm
PH_W1	2H, 3H, 4H, WLG	any combination of harmonics and white-light continuum

Residual fundamental radiation available upon request.

HIRO pumped with ps pulses available on request.

SPECIFICATIONS

Harmonics conversion efficiencies are given as percentage of the input pump power/energy when the repetition rate is up to 200 kHz.

Harmonic	Conversion efficiencies for different HIRO models		Output polarizations
	PH1F1, PH1F2	PH1F3, PH1F4	
2H	>50 %	>50 % ¹⁾	H (V ²⁾)
3H	–	>25 %	V (H ²⁾)
4H	>10 %	>10 % ^{1) 3)}	V (H ²⁾)

¹⁾ When the third harmonic is not in use.

³⁾ Max 1 W.

²⁾ Optional, depending on request.

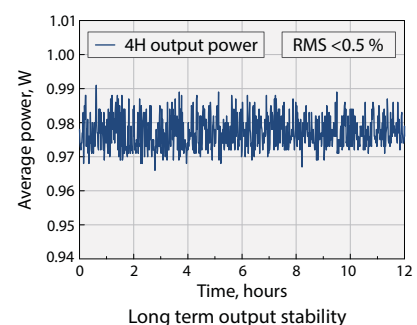

HARMONICS GENERATION

FLINT oscillator can be equipped with optional wavelength converter HIRO providing harmonics radiation at 517 nm, 345 nm and 258 nm wavelengths.

Generated harmonics	2H	3H	4H
Output wavelength	517 nm	345 nm	258 nm
Conversion efficiency	>35 %	>5 %	>1 %

DIMENSIONS (for HIRO all models)

	W x L x H
General dimension of the housing	160 x 455 x 85 mm
Recommended area for fixing	255 x 425 mm
Beam steering/intercepting	55 x 150 x 75 mm

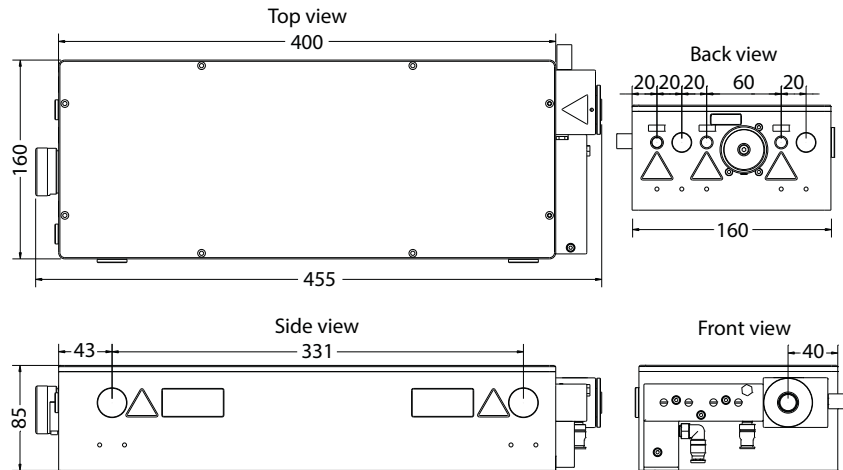

HIRO housing with water cooling system dimensions and positions of input/output ports (mm)

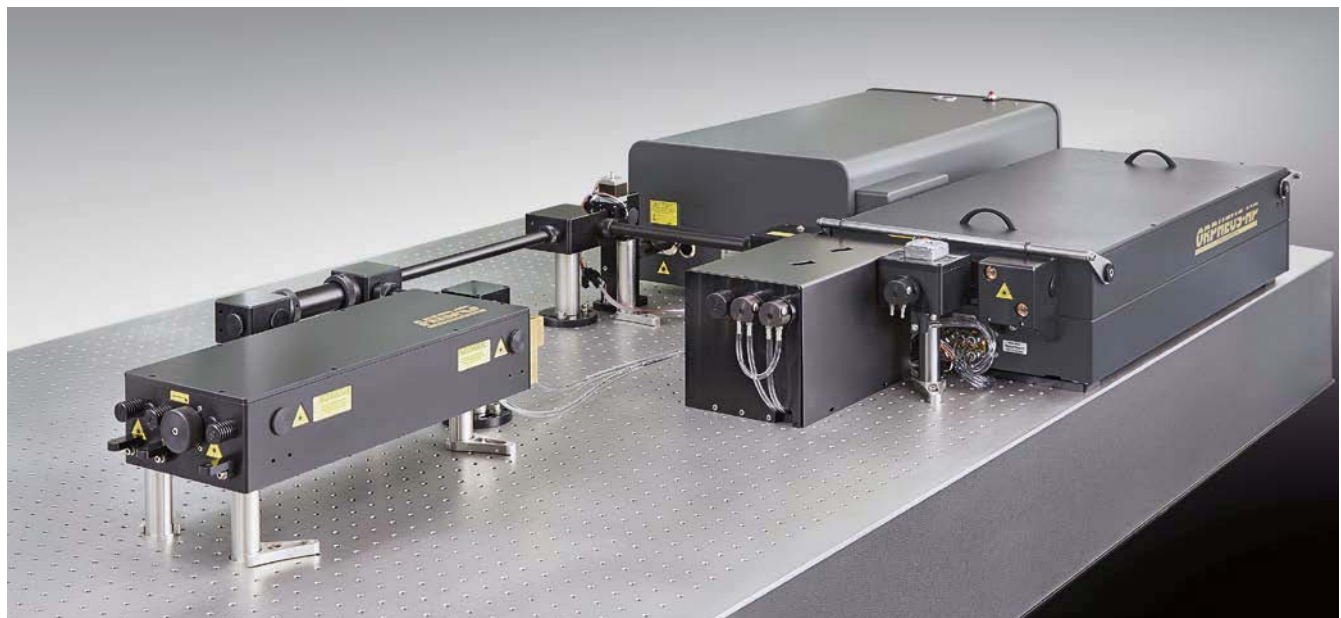

HIRO, PHAROS and ORPHEUS-HP in the lab