

I-OPA



Industrial-Grade Optical Parametric Amplifier

FEATURES

- Tunable or fixed-wavelength models
- Industrial-grade design
- Plug-and-play installation and user-friendly operation
- Single-shot – 2 MHz repetition rate
- Up to 40 W pump power
- < 100 fs pulse duration



I-OPA-TW attached to air-cooled CARBIDE-CB5

The industrial-grade optical parametric amplifier I-OPA series marks a new era of simplicity in the world of wavelength-tunable femtosecond light sources. Based on over 10 years of experience producing the ORPHEUS series of optical parametric amplifiers, this solution brings together the tunability of wavelength with the robust industrial-grade design. The I-OPA is a rugged module attachable to our PHAROS and CARBIDE lasers, providing long-term stability comparable to that of the industrial-grade harmonic generators.

The tunable-wavelength I-OPA (I-OPA-TW) provides a wide tuning range and is primarily intended for spectroscopy and microscopy applications. In particular, the -HP model is targeted to be coupled with our HARPIA spectroscopy

system as a pump beam source for ultrafast pump-probe spectroscopy. The -F model is primarily designed as a light source for multiphoton microscopy, the -ONE model – for IR spectroscopy and other applications where high energy MIR pulses are desired. All of the models can also be used for micromachining and other industrial applications.

The fixed-wavelength I-OPA (I-OPA-FW) is primarily intended for applications that desire a single-wavelength output. The industrial-grade design provides mechanical stability and eliminates the effects of air-turbulence, minimizing energy fluctuations and ensuring stable long-term performance.

The I-OPA-TW is best suited for R&D systems, while the I-OPA-FW is a cost-effective solution for large-scale production.

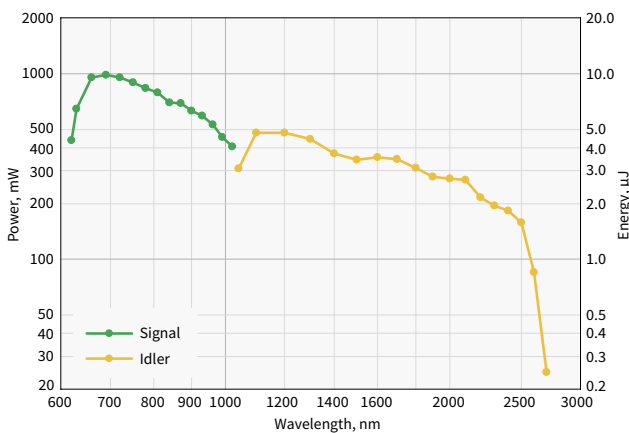

Typical I-OPA-TW-HP tuning curves.
Pump: 10 W, 100 µJ, 100 kHz

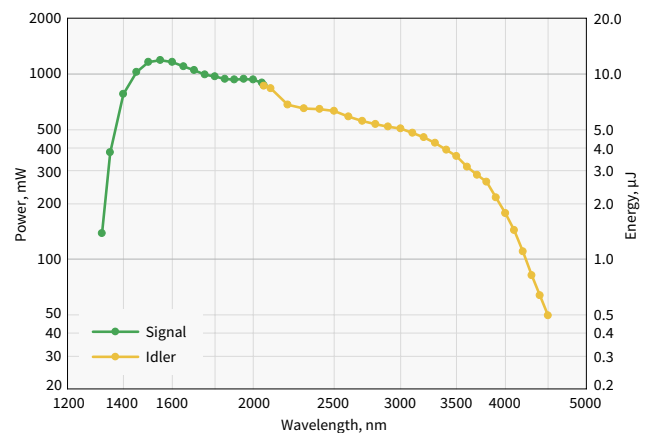

Typical I-OPA-TW-ONE tuning curves.
Pump: 10 W, 100 µJ, 100 kHz

SPECIFICATIONS OF TUNABLE I-OPA

| Model | I-OPA-TW-HP | I-OPA-TW-F | I-OPA-TW-ONE |
|---|--|--|---|
| Configuration | ORPHEUS | ORPHEUS-F | ORPHEUS-ONE |
| Pump power | Up to 40 W | | |
| Pump pulse energy | 10 – 400 μJ | | 20 – 400 μJ |
| Repetition rate | Up to 2 MHz | | |
| Tuning range | 640 – 1010 nm (Signal) 1050 – 2600 nm (Idler) | 650 – 900 nm (Signal) 1200 – 2500 nm (Idler) | 1350 – 2000 nm (Signal) 2100 – 4500 nm (Idler) |
| Conversion efficiency at peak | > 7% @ 700 nm (40 – 400 μJ pump; up to 1 MHz) | | > 9% @ 1550 nm (40 – 400 μJ pump; up to 1 MHz) |
| | > 3.5% @ 700 nm (10 – 40 μJ pump; up to 2 MHz) | | > 6% @ 1550 nm (20 – 40 μJ pump; up to 2 MHz) |
| Spectral bandwidth ¹⁾ | 80 – 220 cm ⁻¹ @ 700 – 960 nm | 200 – 1000 cm ⁻¹ @ 650 – 900 nm 150 – 1000 cm ⁻¹ @ 1200 – 2000 nm | 60 – 150 cm ⁻¹ @ 1450 – 2000 nm |
| Pulse duration ¹⁾²⁾ | 120 – 250 fs | < 55 fs @ 800 – 900 nm < 70 fs @ 650 – 800 nm < 100 fs @ 1200 – 2000 nm | 100 – 300 fs |
| Long-term power stability, 8 h | < 1% @ 800 nm | | < 1% @ 1550 nm |
| Pulse-to-pulse energy stability, 1 min | < 1% @ 800 nm | | < 1% @ 1550 nm |
| Wavelength extension options | 320 – 505 nm (SHS) ³⁾ 525 – 640 nm (SHI) ³⁾ | Contact sales@lightcon.com | 4500 – 10000 nm (DFG) ⁴⁾ |
| Pulse compression options ¹⁾ | – | SCMP (Signal pulse compressor) ICMP (Idler pulse compressor) GDD-CMP (Compressor with GDD control) | – |

¹⁾ I-OPA-TW-F broad-bandwidth pulses are compressed externally. Typical pulse duration before compression: 120 – 250 fs, after compression: 25 – 70 fs @ 650 – 900 nm, 40 – 100 fs @ 1200 – 2000 nm.

²⁾ Output pulse duration depends on the selected wavelength and pump laser pulse duration.

³⁾ Conversion efficiency is 1.2% at peak; specified as the percentage of pump power.

⁴⁾ Up to 16 μm tuning range is accessible with an external difference frequency generator.

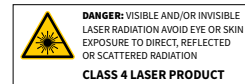

SPECIFICATIONS OF FIXED WAVELENGTH I-OPA

| Model | I-OPA-FW-HP | I-OPA-FW-F | I-OPA-FW-ONE |
|--|---|--|--|
| Configuration | ORPHEUS | ORPHEUS-F | ORPHEUS-ONE |
| Pump power | Up to 40 W | | |
| Pump pulse energy | 10 – 500 μJ | | 20 – 1000 μJ |
| Repetition rate | Up to 2 MHz | | |
| Wavelength selection range ¹⁾ | 640 – 1010 nm (Signal) 1050 – 2600 nm (Idler) | 650 – 900 nm (Signal) 1200 – 2500 nm (Idler) | 1350 – 2000 nm (Signal) 2100 – 4500 nm (Idler) |
| Conversion efficiency at peak | > 7% @ 700 nm (40 – 500 μJ pump; up to 1 MHz) | | > 9% @ 1550 nm (40 – 1000 μJ pump; up to 1 MHz) |
| | > 3.5% @ 700 nm (10 – 40 μJ pump; up to 2 MHz) | | > 6% @ 1550 nm (10 – 40 μJ pump; up to 2 MHz) |
| Spectral bandwidth ²⁾ | 80 – 220 cm ⁻¹ @ 700 – 960 nm | 200 – 1000 cm ⁻¹ @ 650 – 900 nm 150 – 1000 cm ⁻¹ @ 1200 – 2000 nm | 60 – 150 cm ⁻¹ @ 1450 – 2000 nm |
| Pulse duration ²⁾³⁾ | 120 – 250 fs | < 55 fs @ 800 – 900 nm < 70 fs @ 650 – 800 nm < 100 fs @ 1200 – 2000 nm | 150 – 300 fs |
| Long-term power stability, 8 h | < 1% @ 800 nm | | < 1% @ 1550 nm |
| Pulse-to-pulse energy stability, 1 min | < 1% @ 800 nm | | < 1% @ 1550 nm |

¹⁾ A fixed wavelength can be selected from the Signal or Idler range. Signal may have accessible Idler pair, and vice versa.

²⁾ I-OPA-FW-F outputs broad-bandwidth pulses which are compressed externally. Typical pulse duration before compression: 120 – 250 fs, after compression: 25 – 70 fs @ 650 – 900 nm, 40 – 100 fs @ 1200 – 2000 nm.

³⁾ Output pulse duration depends on the selected wavelength and pump laser pulse duration.

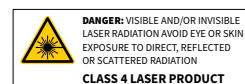

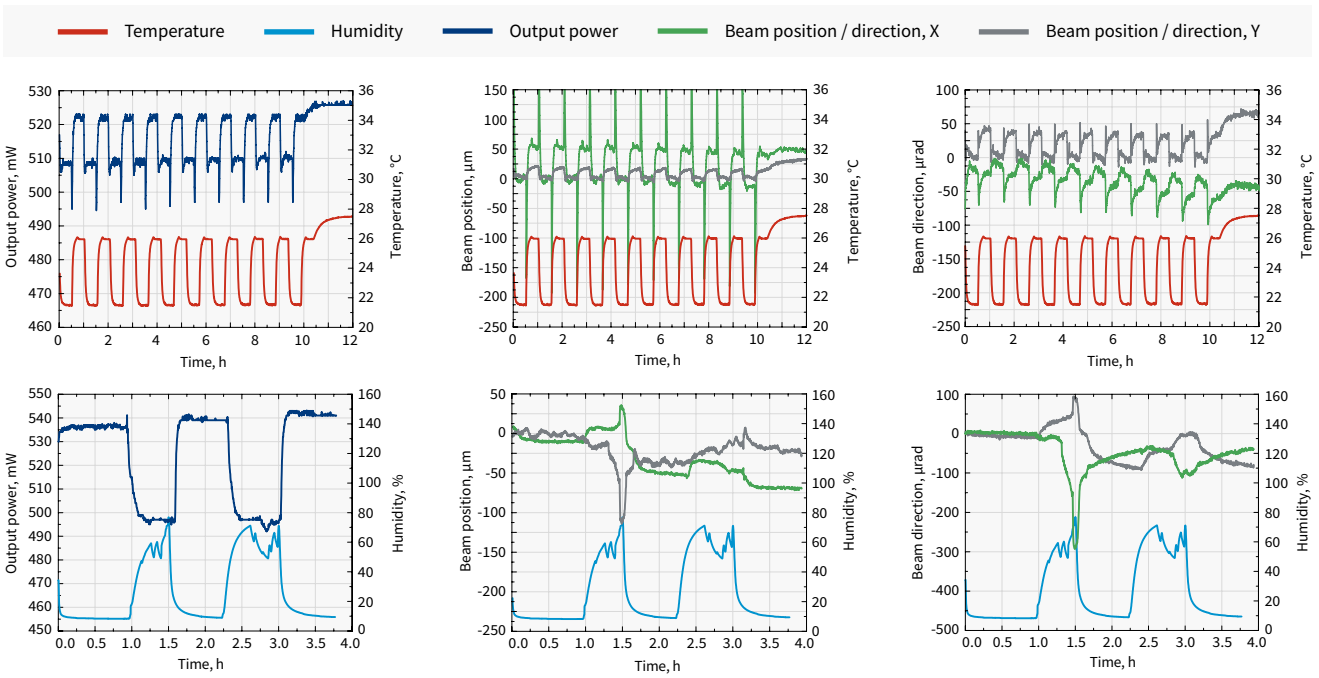

I-OPA-FW output power, beam position, and beam direction under harsh environmental conditions

COMPARISON WITH OTHER FEMTOSECOND AND PICOSECOND LASERS

| Laser technology | Our solution ¹⁾ | Typical performance ²⁾ | | | |
|------------------------------------|----------------------------|-----------------------------------|-------------|--------------------------|--------------|
| | | HG or HIRO | I-OPA-FW-HP | I-OPA-FW-F ³⁾ | I-OPA-FW-ONE |
| Excimer (193 nm, 213 nm) | 5H of laser (205 nm) | > 20 μJ | - | - | - |
| 3H of Ti:Sapphire (266 nm) | 4H of laser (257 nm) | > 40 μJ | - | - | - |
| 3H of Nd:YAG (355 nm) | 3H of laser (343 nm) | > 100 μJ | > 10 μJ | - | - |
| 2H of Nd:YAG (532 nm) | 2H of laser (515 nm) | > 200 μJ | > 140 μJ | - | - |
| Ti:Sapphire (800 nm) | OPA (750 – 850 nm) | - | > 25 μJ | - | - |
| Nd:YAG (1064 nm) | Laser (1030 nm) | - | 400 μJ | - | - |
| Cr:Forsterite (1240 nm) | OPA (1200 – 1300 nm) | - | > 14 μJ | - | - |
| Erbium (1560 nm) | OPA (1500 – 1600 nm) | - | > 10 μJ | - | > 40 μJ |
| Thulium / Holmium (1950 – 2150 nm) | OPA (1900 – 2200 nm) | - | > 7 μJ | - | > 25 μJ |
| MIR sources (2500 – 4000 nm) | OPA (2500 – 4000 nm) | - | - | - | > 5 μJ |

¹⁾ OPA output is not limited to the given spectral ranges; see the full ranges in the specifications above.

²⁾ Typical pulse energy when using 400 μJ pump from CARBIDE/PHAROS laser. Output scales linearly in a broad range of pump parameters. For exact specifications, contact sales@lightcon.com.

³⁾ I-OPA-FW-F broad-bandwidth pulses are compressed externally. For compression options, see specifications above.

DRAWINGS

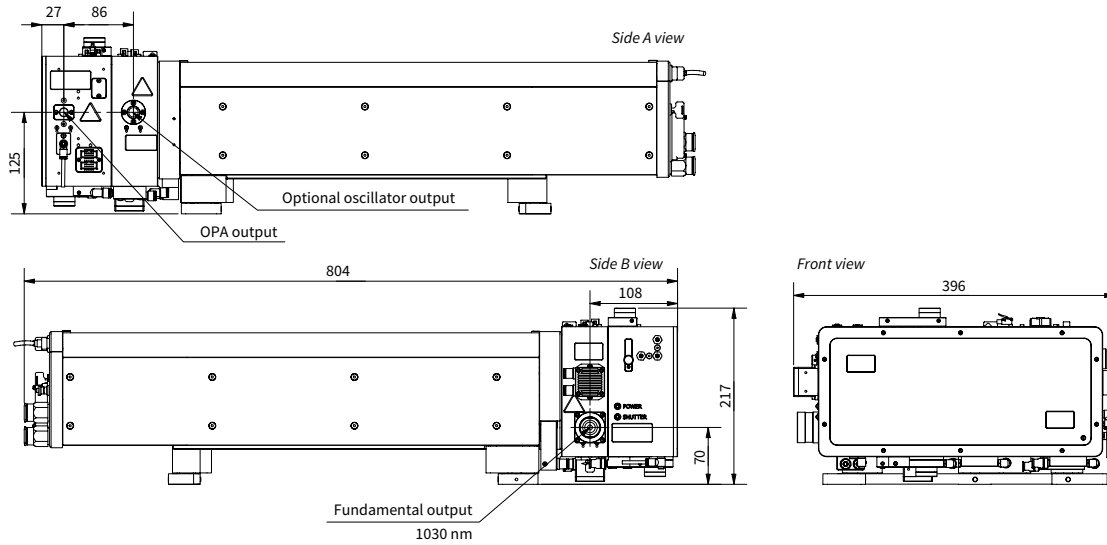

Drawing and output ports of CARBIDE-CB3 with tunable I-OPA-TW-HP

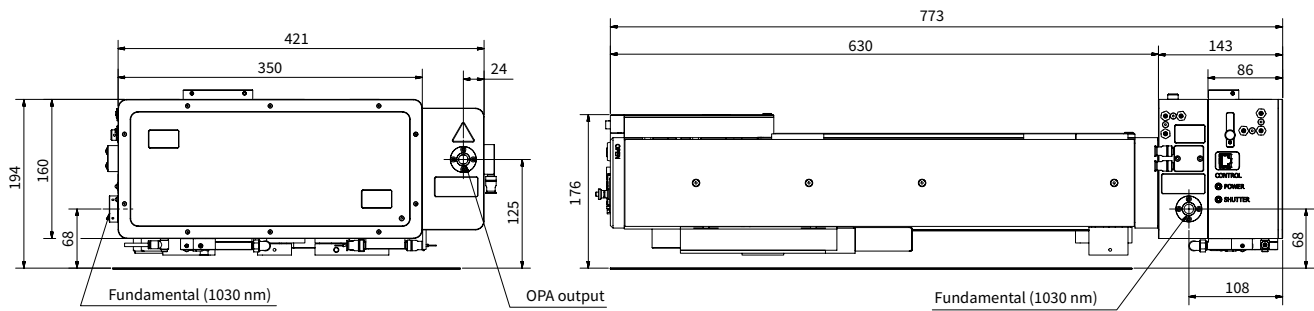

Drawing and output ports of CARBIDE-CB5 with tunable I-OPA-TW-HP

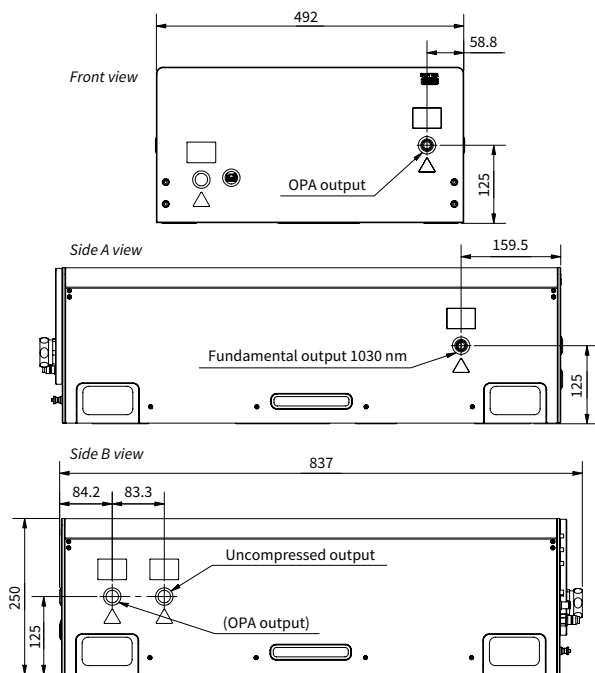

Drawing and output ports of PHAROS-PH2 with tunable I-OPA-TW-HP

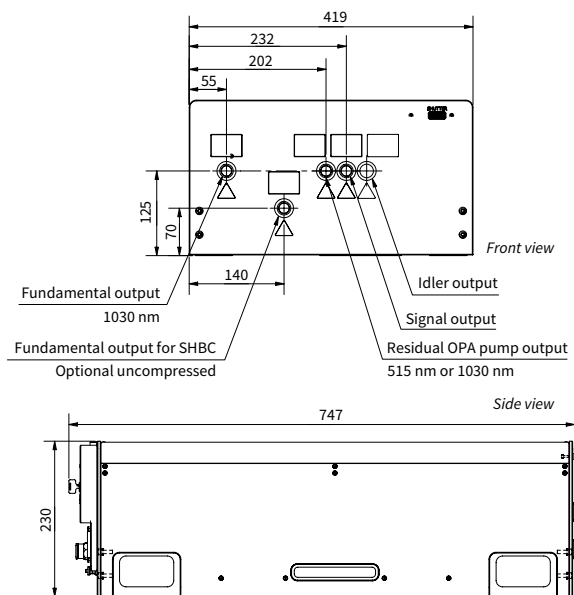

Drawing and output ports of PHAROS-PH2 with fixed-wavelength I-OPA-FW-HP