

I-OPA

Industrial-Grade Optical Parametric Amplifier

Wavelength tunability in an industrial design

Single-box solution

Tunable or fixed-wavelength models

Plug-and-play installation and robust performance

The most compact OPA in the market

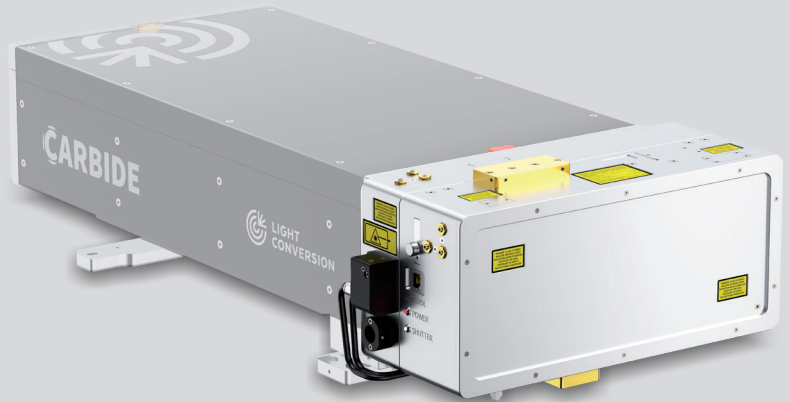

CARBIDE-CB3 with I-OPA-HP

I-OPA-HP typical tuning curves
Pump: 40 W, 400 μ J, 100 kHz

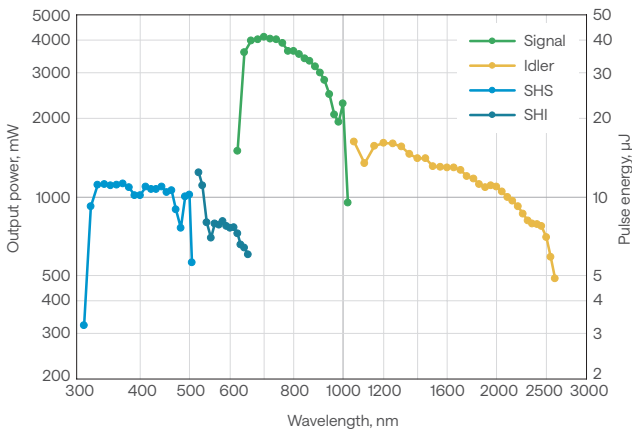

I-OPA-F typical tuning curves
Pump: 40 W, 400 μ J, 100 kHz

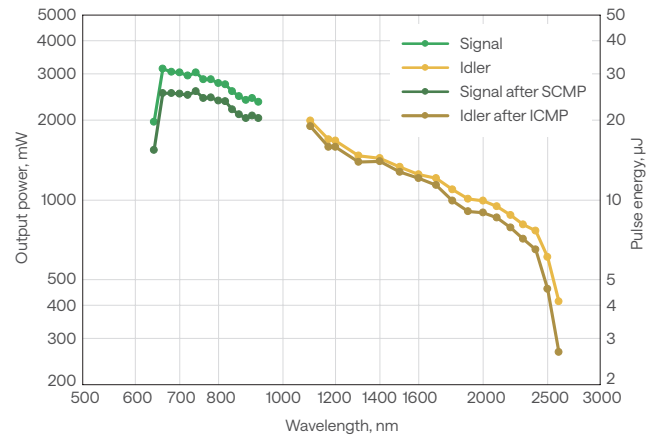

I-OPA-HP
Typical power stability at 1300 nm

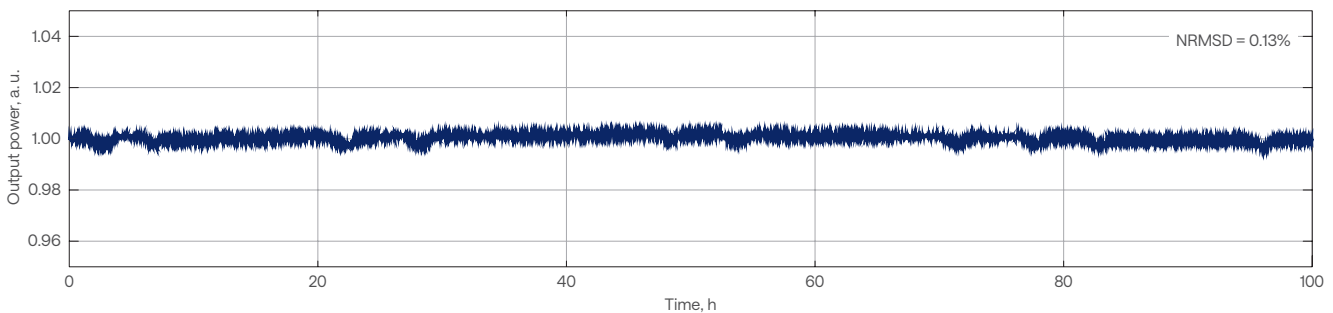

Specifications

Model	I-OPA-HP	I-OPA-F	I-OPA-ONE
Configuration	ORPHEUS	ORPHEUS-F	ORPHEUS-ONE
Pump power	Up to 40 W		
Pump pulse energy	20 – 400 μ J		
Repetition rate	Up to 2 MHz		
Tuning range ¹⁾	640 – 1010 nm (signal) 1050 – 2600 nm (idler)	650 – 920 nm (signal) 1200 – 2500 nm (idler)	1350 – 2000 nm (signal) 2100 – 4500 nm (idler)
Conversion efficiency	> 7% @ 700 nm (40 – 400 μ J pump; up to 1 MHz)		> 9% @ 1550 nm (40 – 400 μ J pump; up to 1 MHz)
	> 3.5% @ 700 nm (20 – 40 μ J pump; up to 2 MHz)		> 6% @ 1550 nm (20 – 40 μ J pump; up to 2 MHz)
Spectral bandwidth ²⁾	80 – 220 cm^{-1} @ 700 – 960 nm	200 – 1000 cm^{-1} @ 650 – 920 nm 150 – 1000 cm^{-1} @ 1200 – 2000 nm	60 – 150 cm^{-1} @ 1450 – 2000 nm
Pulse duration ^{2) 3)}	120 – 250 fs	< 55 fs @ 800 – 920 nm < 70 fs @ 650 – 800 nm < 100 fs @ 1200 – 2000 nm	100 – 300 fs
Long-term power stability, 8 h ⁴⁾	< 1% @ 800 nm		< 1% @ 1550 nm
Pulse-to-pulse energy stability, 1 min ⁴⁾	< 1% @ 800 nm		< 1% @ 1550 nm
Wavelength extension options	320 – 505 nm (SHS) ⁵⁾ 525 – 640 nm (SHI) ⁵⁾	Contact sales@lightcon.com	4500 – 10 000 nm (DFG)
Pulse compression options ²⁾	n/a	SCMP (signal pulse compressor) ICMP (idler pulse compressor)	n/a

PUMP LASER REQUIREMENTS

Pump laser	CARBIDE or PHAROS
Center wavelength	1030 \pm 10 nm
Maximum pump power	40 W
Maximum repetition rate	Up to 2 MHz
Pump pulse energy	20 – 400 μ J
Pulse duration	180 – 300 fs

ENVIRONMENTAL & UTILITY REQUIREMENTS

Refer to lightcon.com

¹⁾ In the case of a fixed wavelength (FW), a single wavelength can be selected from the signal or idler range. The signal may have an accessible idler pair, and vice versa.

²⁾ I-OPA-F broad-bandwidth pulses are compressed externally. Typical pulse duration before compression: 120 – 250 fs, after compression: 25 – 70 fs @ 650 – 920 nm, 40 – 100 fs @ 1200 – 2000 nm.

³⁾ Output pulse duration depends on the selected wavelength and the pump laser pulse duration.

⁴⁾ Expressed as normalized root mean squared deviation (NRMSD).

⁵⁾ Conversion efficiency is 1.2% at peak; specified as a percentage of pump power.

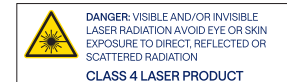

Drawings

CARBIDE-CB3 with I-OPA-HP

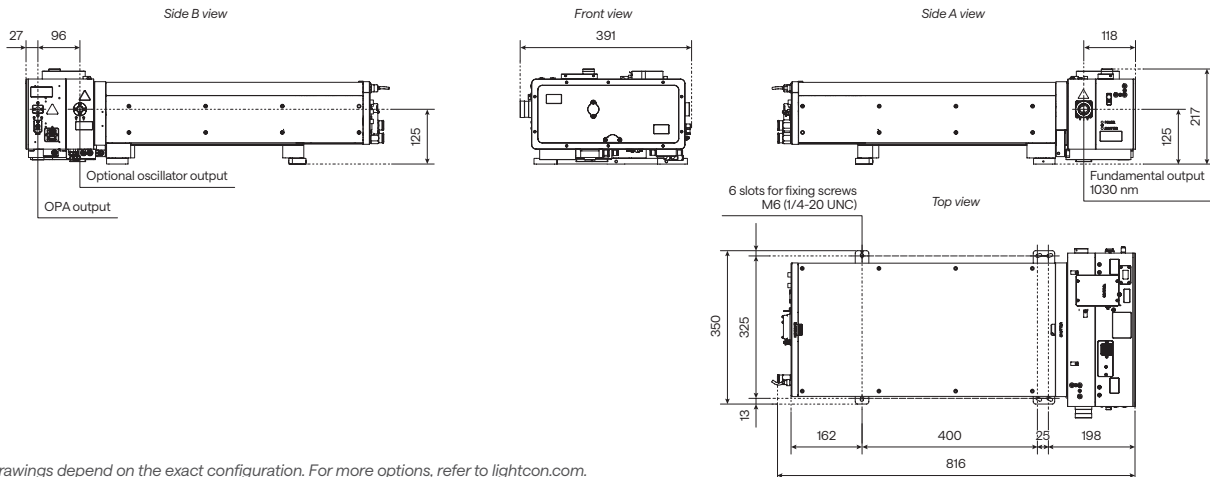

The drawings depend on the exact configuration. For more options, refer to lightcon.com.

