

# Levante IR

## Tunable OPO for IR Pump Laser

- Levante IR is a synchronously pumped Optical Parametric Oscillator with an innovative and user-friendly design. Mode-locked lasers with an output wavelength of 1  $\mu\text{m}$  are suitable as pump lasers. The output wavelength ranges from approx. 1300 nm to 5000 nm.
- The tunable IR OPO is available as picosecond and femtosecond version. Its synchronous pumping scheme provides a jitter-free and stable repetition rate that is identical to the repetition rate of the pump laser.



- Automated wavelength tuning
- Synchronous pumping scheme
- Standard Software Interface (using TCP/IP)
- Integrated spectrometer for OPO Signal wavelength range

## Automated Tuning for IR Wavelength Range

- The output wavelength range for the Signal beam is 1315 ... 2000 nm and the wavelength for the Idler output ranges from 2150 ... 5000 nm. This is ideal for applications that require tunable radiation in the IR range, e.g. vibrational spectroscopy. The wavelength tuning is fully automated.
- An extended wavelength range from 660 nm to 15  $\mu\text{m}$  can be generated when Levante IR is operated in combination with APE's HarmoniXX series. Wavelength converters SHG (Second Harmonic Generation), THG (Third Harmonic Generation) and DFG (Difference Frequency Generation) are available.

## Control Software and TCP/IP Standard Software Interface

- All models come with an easy to use control software, allowing for real-time data display. Furthermore, the TCP/IP-based standard software interface by APE makes it straight forward to set up remote control. This allows you, for example, to design your own automated measurement routines. Simply use our protocol templates for rapid configuration with familiar programming languages, including C++, C#, LabVIEW, Python, Matlab, and Ruby.

## Software-Interface

- The Levante IR comes with an easy-to-use control interface with real-time data display.



# Levante IR Specifications

## ps Version

|                             |   |
|-----------------------------|---|
| Signal Wavelength Range     | 1320 ... 2000 nm  |
| Idler Wavelength Range      | 2150 ... 4800 nm (typ. ... 5000 nm)   |
| Signal Power                | 1.6 W at 1500 nm pumped with 8 W  |
| Idler Power                 | 0.7 W at 2500 nm pumped with 8 W  |
| Pulse Width                 | typ. 2 ps at 2 ps pump pulse width  |
| Time Bandwidth Product      | typ. 0.6  |
| Repetition Rate             | Equal and synchronous to pump laser   |
| Wavelength Tuning           | Fully automated   |
| Wavelength Tuning Feedback  | In-built spectrometer   |
| Software                    | Included  |
| Remote Control              | Available via TCP/IP  |
| Appropriate Pump Parameters | Wavelength 1030 ... 1064 nm<br>Power 2 ... 10 W<br>Pulse width 1 ... 10 ps<br>Repetition rate ~ 73 ... 82 MHz; fixed at the time of order |
| Evaluated Pump Laser        | APE Emerald Engine<br>APE picoEmerald with additional IR output   |

## fs Version

|                             |  |
|-----------------------------|--|
| Signal Wavelength Range     | 1320 ... 2000 nm   |
| Idler Wavelength Range      | 2150 ... 4800 nm (typ. ... 5000 nm)  |
| Signal Power                | 2.4 W at 1500 nm pumped with 12 W  |
| Idler Power                 | 1.2 W at 2500 nm pumped with 12 W  |
| Pulse Width                 | typ. 200 fs at 200 fs pump pulse width   |
| Time Bandwidth Product      | typ. 0.6   |
| Repetition Rate             | Equal and synchronous to pump laser  |
| Wavelength Tuning           | Fully automated  |
| Wavelength Tuning Feedback  | In-built spectrometer  |
| Software                    | Included   |
| Remote Control              | Available via TCP/IP   |
| Appropriate Pump Parameters | Wavelength 1030 ... 1064 nm<br>Power 2 ... 12 W<br>Pulse width 70 ... 300 fs<br>Repetition rate ~ 73 ... 82 MHz; fixed at the time of order              |
| Evaluated Pump Laser        | Coherent Discovery<br>Coherent Fidelity HP 10<br>Light Conversion FLINT<br>Menlo Orange High Power 10<br>Spectra Physics Insight X3+<br>Toptica FF-Ultra |

All specifications are pending on actual Pump Laser parameter - please contact us for technical details.

# ... Specifications

## Typical Data

Levante IR fs - typical Idler spectra

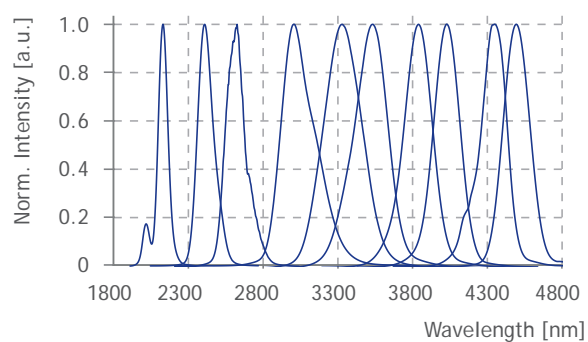

Levante IR fs - typical Signal spectra

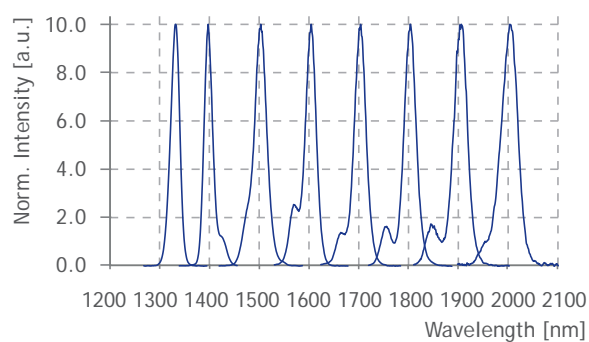

Levante IR fs pumped by 12 W - typical Signal and Idler power

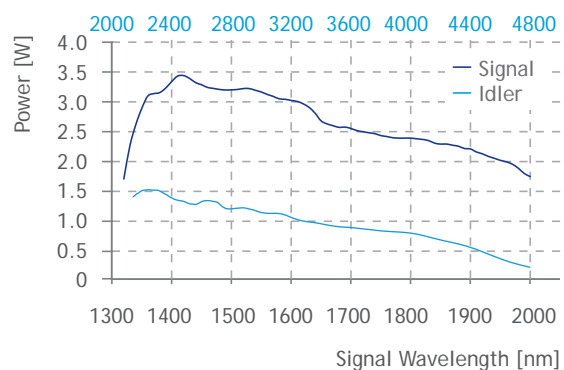

## Options

Harmonic Generation SHG or THG for Signal

Harmonic Generation SHG or THG for Idler

Difference Frequency Generation DFG up to 15  $\mu\text{m}$

Adaption to other pump parameters

## Dimensions

1169 mm x 204 mm x 402 mm

## Drawings

See appendix for details

# Appendix Technical Drawings

All dimensions in mm

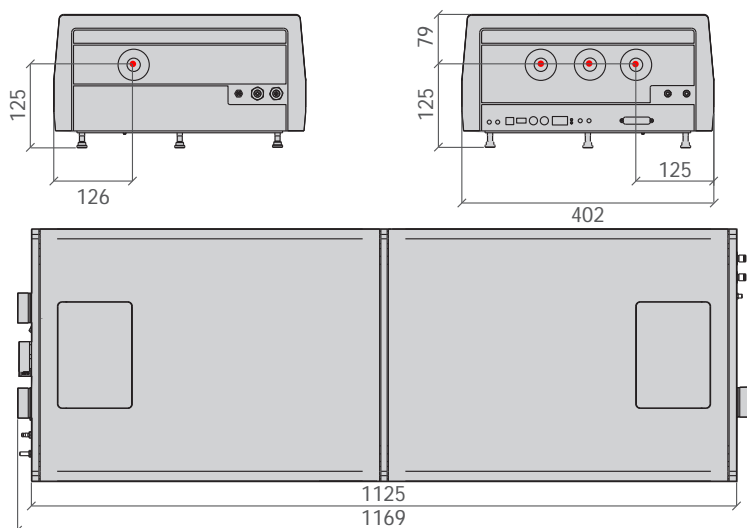

## Contact

APE Angewandte Physik & Elektronik GmbH

Plauener Str. 163-165 | Haus N | 13053 Berlin | Germany

T: +49 30 986 011-30

F: +49 30 986 011-333

E: sales@ape-berlin.de

www.ape-berlin.de

**PHOTO** [www.phototechnica.co.jp](http://www.phototechnica.co.jp)  
**TECHNICA** フォトテクニカ株式会社

〒336-0017 埼玉県さいたま市南区南浦和 1-2-17

TEL:048-871-0067 FAX:048-871-0068

e-mail:voc@phototechnica.co.jp

APE follows a policy of continued product improvement. Therefore, specifications are subject to change without notice.

© APE GmbH | January 2021 | Rev. 3.2.0