

LightWire FPS series

Compact
Fiber Seeders for
Picosecond Lasers



FEATURES

- ▶ Pulse energy >50 nJ at repetition rate <1 MHz
- ▶ Sub-10 ps pulse duration
- ▶ Close to Fourier-transform limited spectral bandwidth
- ▶ Integrated fiber pulse picker for flexible repetition rate control (20 kHz – 40 MHz, burst mode available)

APPLICATIONS

- ▶ Seeding solid state amplifiers

LightWire FPS series fiber lasers are dedicated for seeding solid state Nd:YAG amplifiers. Compact, cost efficient FPS series models deliver sub-10 ps pulses at 1064 nm wavelength with the average output power up to 200 mW and pulse

energy up to 50 nJ. They feature narrow close to bandwidth limited spectrum and low pulse amplitude noise. Wavelength tunability ensures that seed pulses are always spectrally overlapped with the amplification spectrum of your amplifier.

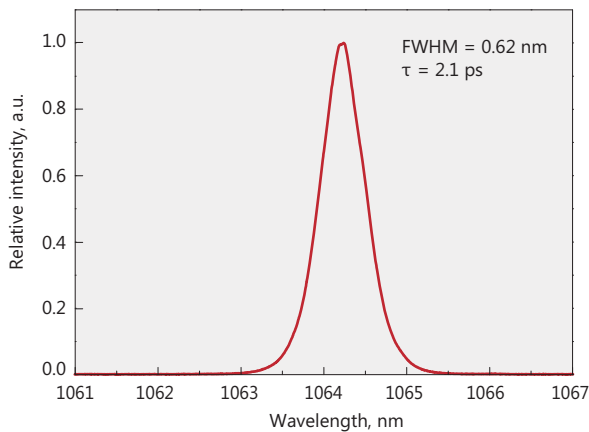

Typical spectrum from FPS10 laser

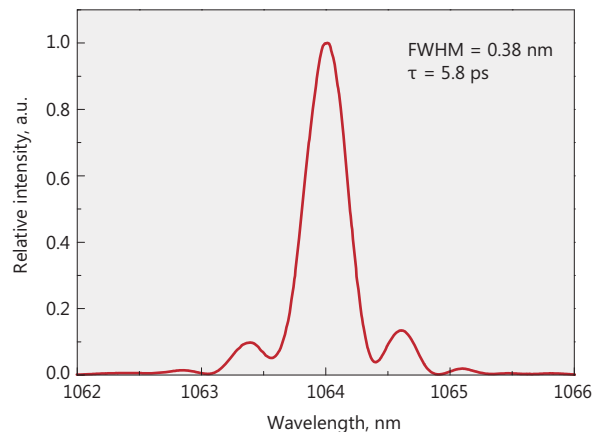

Typical spectrum from FPS100 laser

SPECIFICATIONS ¹⁾

Model	FPS10	FPS100	FPS200
Central wavelength	1064 nm, tunable ± 0.2 nm		
Pulse duration	2.3 ± 0.3 ps	7 ± 1 ps	9 ± 1 ps
Spectral bandwidth	0.7 ± 0.2 nm	0.4 ± 0.1 nm	0.25 ± 0.05 nm
Oscillator pulse repetition rate	40 ± 2 MHz		
Pulse repetition rate with pulse picker ²⁾	20 kHz – 40 MHz (PRR = PRR _{osc} / N, N = 1, 4, 5, ..., 2000)		
Output power (without/with pulse picker)	> 2 mW / > 1 mW	> 80 mW / > 40 mW	> 200 mW at 10 MHz > 40 mW at 1 MHz > 5 mW at 100 kHz
Pulse energy (without/with pulse picker)	> 50 pJ / > 25 pJ	> 2 nJ / > 1 nJ	> 50 nJ at repetition rates < 200 kHz
Polarization	linear, > 100:1 extinction		
Optical output	FC/APC connector or collimator with mounting flange (optional)		collimator & isolator node ³⁾
Umbilical	3 m length armored cable $\varnothing 5$ mm		
Collimated beam diameter	0.9 ± 0.1 mm or 1.3 ± 0.1 mm or 2.1 ± 0.2 mm		0.9 ± 0.1 mm
Beam height	NA		38 mm
Beam quality	$M^2 < 1.1$		
Pulse train monitoring	photodiode output for oscillator train, TTL synch pulse for laser output (when pulse picker included)		
Dimensions of control unit (L x W x H)	315 x 450 x 95 (stand alone) or 315 x 482 x 95 (19" rack mountable)		
Dimensions of collimator (D x L)	$\varnothing 33 \times 11.76$ mm		
Dimensions of collimator & isolator node (L x W x H)	138 x 66.6 x 52 mm		
Weight	< 10 kg		
Control interface	USB, CAN, RS232, LAN, (WLAN option)		
Power supply (AC/DC adapter included)	100–240 V, 50–60 Hz AC		
Power consumption	maximal 230 W (typical 60 W)		
Operating conditions	10–30 °C, humidity – not condensing		



¹⁾ Due to continuous improvement all specifications are subject to change without notice.
²⁾ Pulse picker is an option for FPS10, FPS100 models. It supports external gating. FPS200 includes internal frequency divider, which enables pulse repetition rate reduction but does not support external gating.
³⁾ FPS200 model is provided with collimator & isolator node with dimensions 138x66.6x52 mm.

PERFORMANCE

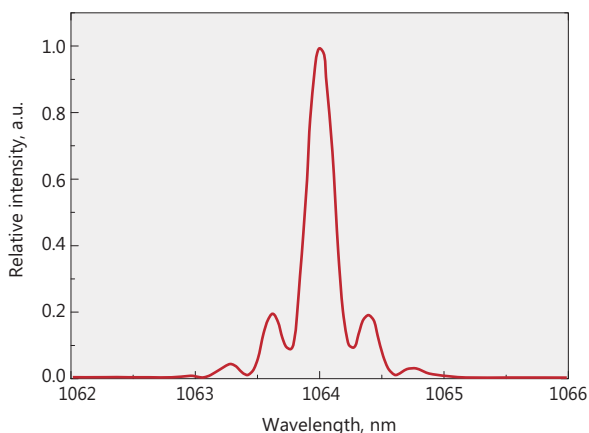

Typical spectrum from FPS200 laser

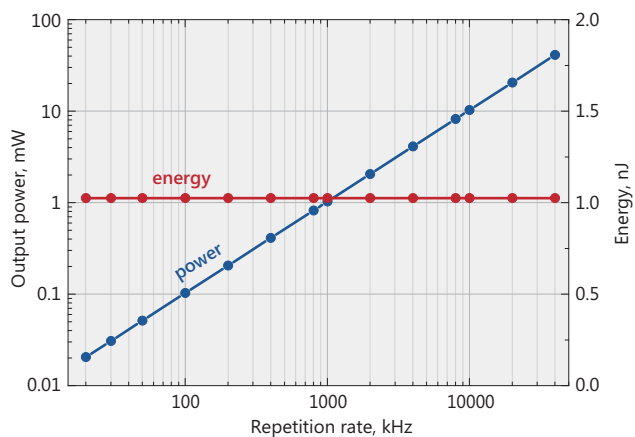

Typical dependence of average power (blue curve) and pulse energy (red curve) on the repetition rate for FPS100-AOM laser

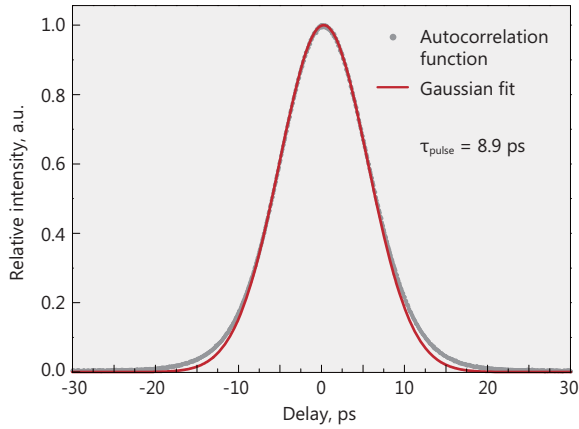

Typical autocorrelation curve of FPS200 laser

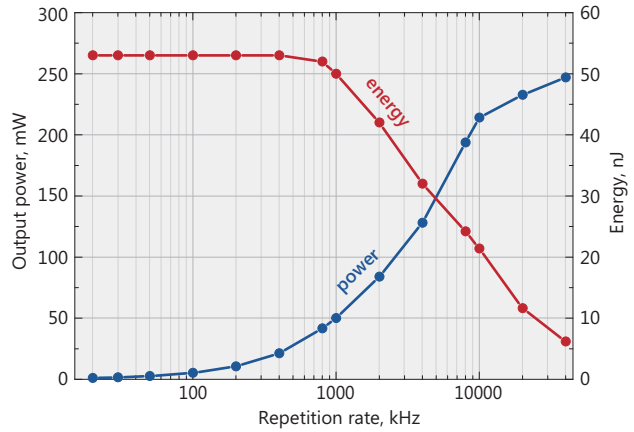

Typical dependence of average power (blue curve) and pulse energy (red curve) on the repetition rate for FPS200 laser

DRAWINGS

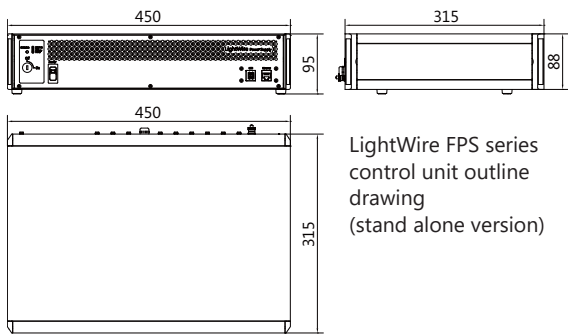

LightWire FPS series control unit outline drawing (stand alone version)

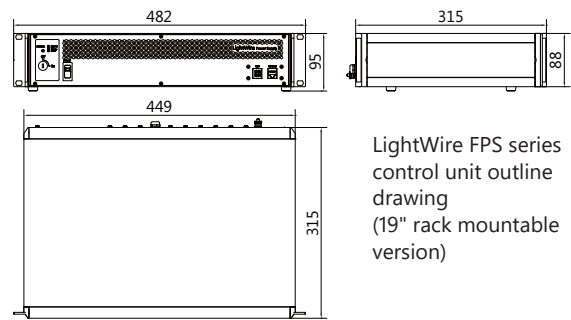

LightWire FPS series control unit outline drawing (19" rack mountable version)

Three Ø3.18 mm thru holes
120° apart on a 29.21 mm
diameter bolt circle

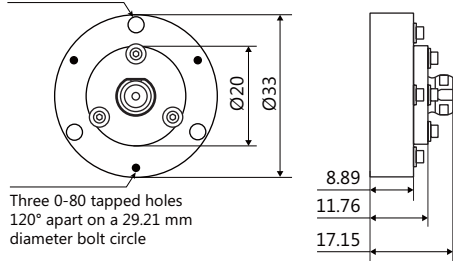

Three 0-80 tapped holes
120° apart on a 29.21 mm
diameter bolt circle

LightWire FPS10/100 laser collimator flange outline drawing for beam diameters 0.9 mm and 1.3 mm

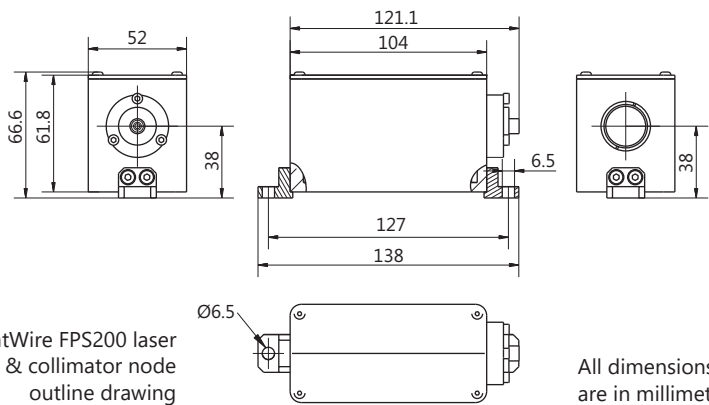

LightWire FPS200 laser isolator & collimator node outline drawing

All dimensions are in millimetres.

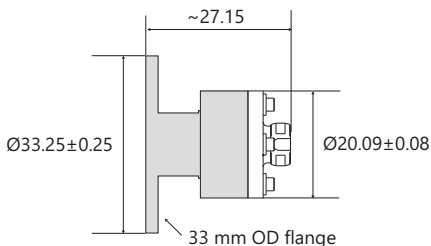

LightWire FPS10/100 laser collimator flange outline drawing for beam diameter 2.1 mm