

OPO-X

Tunable OPO For Ti:Sa Lasers

- OPO-X, a synchronously pumped Optical Parametric Oscillator (OPO), is ideal for wavelength extension of modelocked fs or ps Ti:Sapphire lasers.
- It is suitable for both femtosecond and picosecond Ti:Sa lasers. The wavelength range covers the spectrum from 505 ... 4000 nm.



- Wavelength extension for Ti:Sa laser
- e.g. for Mira (HP), Chameleon Ultra II and Vision II, Tsunami, MaiTai, etc.
- Independent Pump- and Signal tuning
- Fully automated tuning
- Windows-based control software included
- Jitter-free generation of pulses

Customization

OPO-X can be provided with several options and modifications:

- Output of Idler beam (in addition to output of Signal beam)
- Depleted pump output (not in combination with Idler)
- Customized wavelength ranges
- Adaptation to various pump laser cavity lengths and pump pulse width
- Difference Frequency Generation device for MIR generation up to 11 μm
- Simultaneous access to IR and VIS output, and Idler

Maximum Flexibility

- OPO-X is based on a FAN crystal architecture. Great flexibility is given because the OPO wavelength can be set independently of the pump wavelength. Any wavelengths between 740 nm and 880 nm are suitable for pumping.

Femto- or Picosecond Operation

- All OPO-X systems can be operated in both femtosecond and picosecond mode, depending on the corresponding pump laser. Optic components are available for this purpose, which can be easily exchanged by the user.

Automated Tuning

- The actual Signal wavelength and bandwidth is measured by an internal high-resolution spectrometer, and the power by calibrated photodiodes.
- The OPO-X is also equipped with diagnostics for the Pump wavelength, power and repetition rate. The wavelength tuning is done by simply entering the desired wavelength into the OPO control software.
- Even a change in the pump wavelength is detected and the OPO-X adapts automatically. The OPO-X is completely controllable via PC.

OPO-X Specifications

Required Pump Laser (not incl.)

Pump Laser Type	Ti:Sapphire Laser
Pump Wavelength	- 740 ... 880 nm

Specifications

Wavelength Output Range (Signal)	1000 ... 1600 nm (depending on input wavelength)
Wavelength Output Range (Signal SHG)	505 ... 740 nm (depending on input wavelength)
Wavelength Output Range (Idler, optional)	1750 ... 4000 nm (depending on input wavelength)
Time Bandwidth Product	Typically 0.6
Polarization Signal and Idler	Linear / horizontal
Polarization Signal SHG	Linear / vertical
Beam Quality M^2	< 1.2
Spectrometer Range	495 ... 1630 nm
Repetition Rate	- 76 ... - 80 MHz, depending on and equal to the repetition rate of the pump lasers; others on request
Noise	< 0.5% RMS measured for bandwidth from 10 Hz ... 1 MHz
Wavelength Tuning	Fully automated for specified automated tuning range Signal tuning independent from pump tuning
Wavelength Tuning Feedback	Built-in spectrometer
Software	Included
Remote Control	TCP/IP

Specifications fs Version

Output Power at 1100 nm (Signal), pumped at 800 nm

Coherent Chameleon Ultra II, Mira HP	> 650 mW at 3.5 W pump
Coherent Mira V10	> 250 mW at 1.3 W pump
Coherent Mira V5	> 75 mW at 0.65 W pump

Output Power at 600 nm (Signal SHG), pumped at 800 nm

Coherent Chameleon Ultra II, Mira HP	> 500 mW at 3.5 W pump
Coherent Mira V10	> 150 mW at 1.3 W pump
Coherent Mira V5	> 40 mW at 0.65 W pump

Pulse Width Typ. 200 fs at 130 fs pump

... Specifications

Specifications ps Version

Output Power at 1100 nm (Signal), pumped at 800 nm

Coherent Mira HP	> 520 mW at 2.8 W pump
Coherent Mira V10	> 250 mW at 1.3 W pump
Coherent Mira V5	> 75 mW at 0.65 W pump

Output Power at 600 nm (Signal SHG), pumped at 800 nm

Coherent Mira HP	> 400 mW at 2.8 W pump
Coherent Mira V10	> 150 mW at 1.3 W pump
Coherent Mira V5	> 40 mW at 0.65 W pump

Pulse Width Typ. 1.6 ps at 2 ps pump

OPO-X Tuning

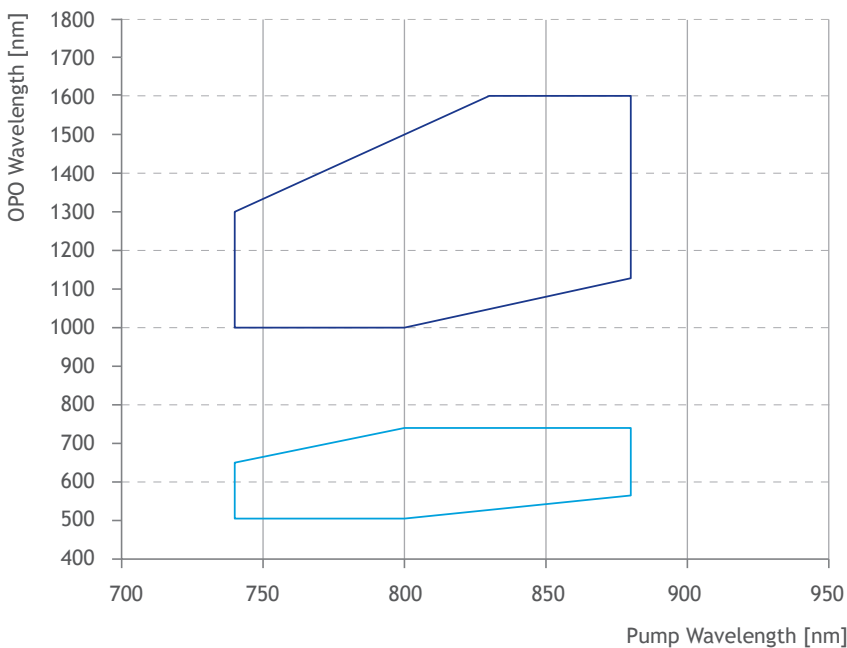

Linear configuration
Intra cavity SHG (VIS) - Ring configuration

Possible wavelength combinations are within the lined area

Options

- Output of Idler beam (in addition to output of Signal beam)
- Depleted pump output (not in combination with Idler)

Dimensions

1169 mm x 204 mm x 402 mm; See appendix for details

Appendix Technical Drawings

All dimensions in mm

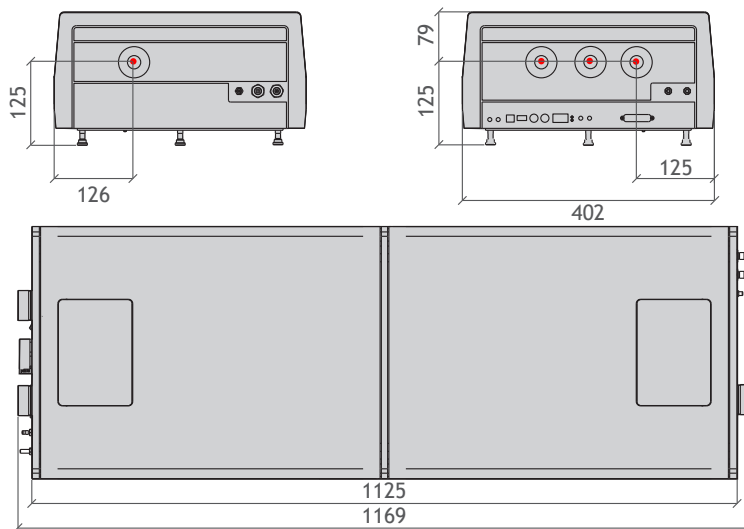

Contact

APE Angewandte Physik & Elektronik GmbH

Plauener Str. 163-165 | Haus N | 13053 Berlin | Germany
 T: +49 30 986 011-30
 F: +49 30 986 011-333
 E: sales@ape-berlin.de
 www.ape-berlin.de

**PHOTO
TECHNICA** www.phototechnica.co.jp
 フォトテクニカ株式会社
 〒336-0017 埼玉県さいたま市南区南浦和 1-2-17
 TEL:048-871-0067 FAX:048-871-0068
 e-mail:voc@phototechnica.co.jp

APE follows a policy of continued product improvement. Therefore, specifications are subject to change without notice.

© APE GmbH | January 2019 | Rev. 3.1.1