



Second Harmonic Bandwidth Compressor



FEATURES

- High conversion efficiency to the narrow bandwidth second harmonic
- Small footprint

PHAROS/CARBIDE harmonic generator product line features second harmonic bandwidth compressor abbreviated as SHBC. The device is dedicated for the formation of narrow bandwidth picosecond pulses from broadband output of ultrafast laser. In PHAROS/CARBIDE platform SHBC is used to create flexible setups providing fixed wavelength or tunable narrow bandwidth ps pulses in combination with tunable wavelength broadband fs pulses. This feature is used in spectroscopy applications for mixing of wide and narrow bandwidth pulses such as sum frequency spectroscopy (SFG). This setup allows efficient SH generation and so provides high pulse energies.

SPECIFICATIONS

Parameter	Value
Pump source	PHAROS / CARBIDE laser, 1030 nm, 70 – 120 cm ⁻¹ , 10 – 2000 μJ input pulse energy
Output wavelength	515 nm
Conversion ratio	> 30 %
Output pulse bandwidth	< 10 cm ⁻¹

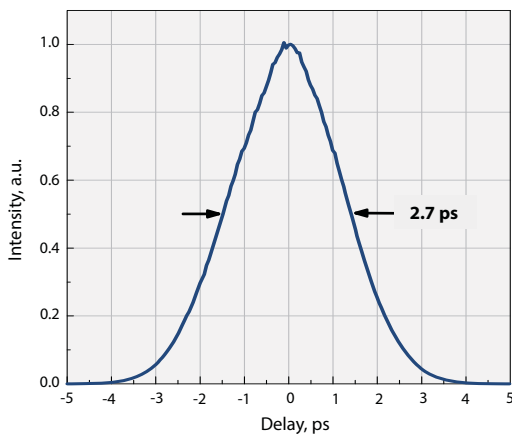

Typical pulse duration SHBC output

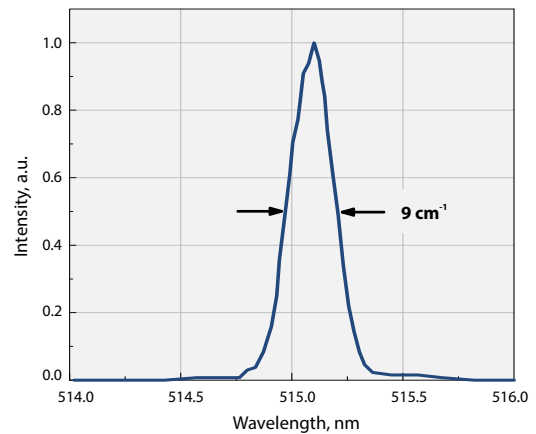

Typical spectrum of SHBC output

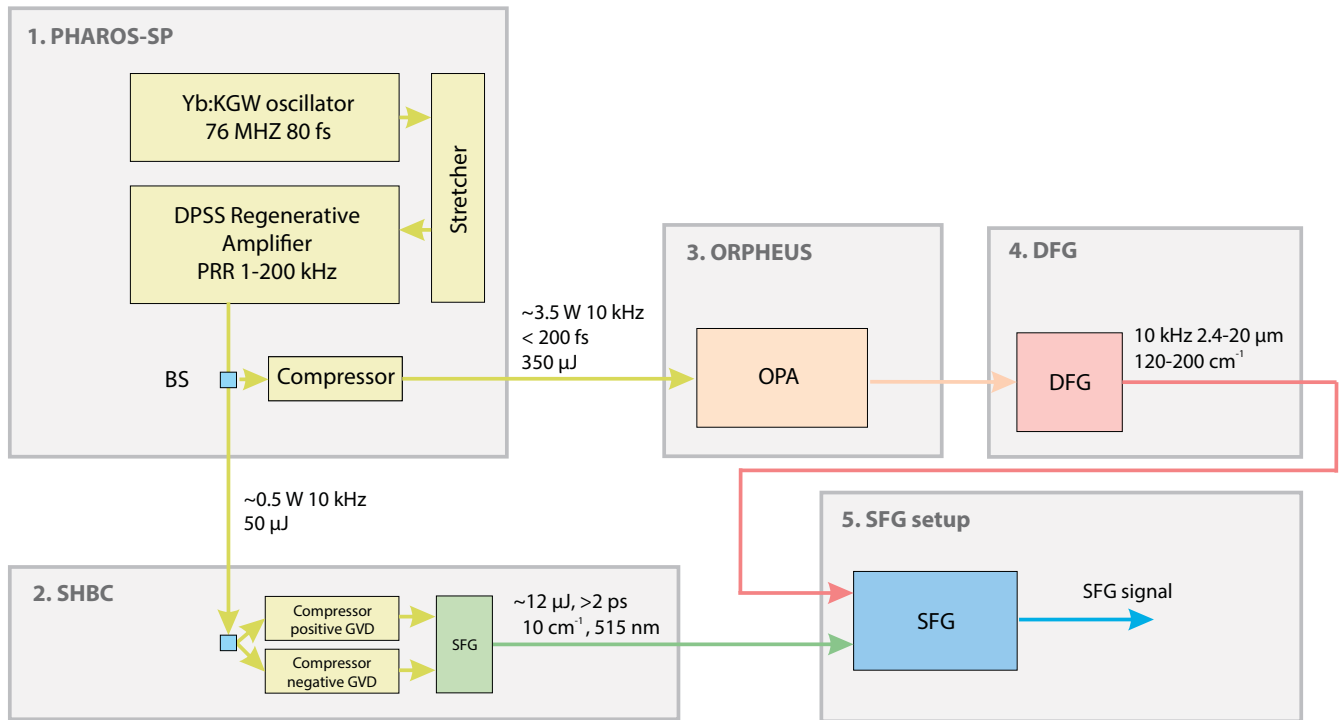

Principal layout of femtosecond sum frequency generation (SFG) spectroscopy system using SHBC to produce one of the probe beams

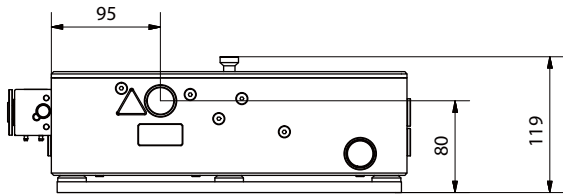

DIMENSIONS

	W × L × H
General dimension of the housing	351 × 426 × 119 mm
Recommended area for fixing	400 × 450 × 150 mm

