

# NT260 SERIES



## Narrow Linewidth 10 kHz Tunable Lasers

### BENEFITS

- ▶ Hands-free wavelength tuning – no need for physical intervention
- ▶ High 10 kHz pulse repetition rate – fast data collection
- ▶ Narrow linewidth (~2 times better than traditional OPO) – high resolution of recorded spectrum
- ▶ Small M2 beam parameter (~2 times better than traditional OPO) – tight focusing of the beam
- ▶ Excellent stability (~2 times better than traditional OPO) – fast acquisition of data
- ▶ Lower generation threshold – increased reliability
- ▶ Motorized output shutters – increased safety
- ▶ Clean air purging for prolonged lifetime of optics
- ▶ Wavelength set in nm and  $\text{cm}^{-1}$  – easy operation of experiment
- ▶ High tuning resolution 1-2  $\text{cm}^{-1}$  – high quality spectra
- ▶ Variety of control interfaces: USB, RS232, LAN and WLAN – easy integration with other equipment
- ▶ PC control using text commands – simple control from any OS

NT262 is a unique narrow linewidth 10 kHz OPO. Pioneering patented technology enables powerful up to 0.7 W output in 192 – 2600 nm wavelengths range while maintaining  $< 3 \text{ cm}^{-1}$  (typically  $< 2 \text{ cm}^{-1}$  at most wavelengths) linewidth that is highly beneficial for traditional and specific applications requiring narrow linewidth and high spectral brightness pulses. Thus, besides the most of popular applications, like fluorescence and pump-probe, the system is also suitable for such demanding

applications where high resolution and narrow linewidth are required, like the calibration of detectors and spectroradiometers, metrology or gas spectroscopy. High 10 kHz repetition rate and hands-free wavelength tuning makes easy and fast experiment data collection as never before. The system is highly stable, ensures excellent short and long-term energy and power stability, has smaller  $M^2$  value if compared with traditional OPO systems.

### FEATURES

- ▶ Pioneering patented Q-switched/ mode-locked operation technology
- ▶ Hands-free no gap wavelength tuning in 192 – 2600 nm range
- ▶ 10 kHz repetition rate
- ▶ Up to 0.7 W output
- ▶ Down to  $1.5 \text{ cm}^{-1}$  linewidth
- ▶ Integrated monitoring of pump and output power
- ▶ Integrated fast wavelength scan
- ▶ Monolithic rugged frame
- ▶ Transportation handles
- ▶ Flexible control from keypad or PC
- ▶ Two years warranty

### APPLICATIONS

- ▶ Metrology & equipment calibration
- ▶ Alignment of a hyperspectral camera
- ▶ Time-of-flight mass spectrometry (TOF)
- ▶ Semiconductor inspection
- ▶ Evaluation of optical filters
- ▶ Photoacoustic microscopy
- ▶ Laser-induced luminescence spectroscopy
- ▶ Environment monitoring, LIDAR

In addition to superior specifications, the laser is highly reliable due to low generation threshold and easy running regime. The system fits into monolithic, rugged housing that ensure high reliability and low costs of maintenance.

**SPECIFICATIONS <sup>1)</sup>**

Model	NT262
<b>OPO</b>	
Wavelength range <sup>2)</sup>	
Signal	405 – 710 nm
Idler	710 – 2600 nm
SH/SF generator (optional)	210 – 405 nm
DUV generator (optional)	192 – 210 nm
Output pulse energy/ average power	
OPO <sup>3)</sup>	70 µJ / 700 mW
SH/SF generator (optional) <sup>4)</sup>	6 µJ / 60 mW
DUV generator (optional) <sup>5)</sup>	1 µJ / 1 mW
Minimal tuning step	
Signal (405 – 710 nm)	1 cm <sup>-1</sup>
Idler (710 – 2600 nm)	1 cm <sup>-1</sup>
SH/SF (210 – 405 nm)	2 cm <sup>-1</sup>
DUV (192 – 210 nm)	2 cm <sup>-1</sup>
Pulse and beam parameters	
Pulse duration <sup>6)</sup>	~7 ns
Linewidth <sup>7)</sup>	<3 cm <sup>-1</sup>
Typical beam diameter <sup>8)</sup>	4.5 mm × 2.5 mm
Beam pointing stability <sup>9)</sup>	≤ 50 µrad RMS
Polarization	
Signal beam	Horizontal
Idler beam	Horizontal
SH/SF	Horizontal
DUV	Vertical
<b>PUMP LASER <sup>10)</sup></b>	
Pump wavelength	355 nm
Typical pump pulse energy	0.3 mJ
Pulse duration	~7 ns
Beam quality	Near Gaussian in near and far fields
Beam divergence	< 1.5 mrad
Pulse energy stability (StdDev)	< 2.5 %
Pulse repetition rate	10 kHz
Nominal lifetime for pump diodes	20 000 hours
Typical warm-up time <sup>11)</sup>	15 min
<b>PHYSICAL CHARACTERISTICS</b>	
Laser head size (W × L × H)	400 × 790 × 166 ± 3 mm
Power supply unit size (W × L × H)	553 × 510 × 529 ±3 mm
Umbilical length	3 m
<b>OPERATING REQUIREMENTS</b>	
Cooling <sup>12)</sup>	Built-in chiller
Clean air purge	Built-in
Room temperature	18 – 27 °C
Ambient temperature stability	±2°C
Relative humidity	20 – 80 % (non-condensing)
Power requirements	100 – 240 VAC, single phase 50/60 Hz
Power consumption	<1 kW
Cleanliness of the room	Not worse than ISO Class 9

- <sup>1)</sup> Due to continuous improvement, all specifications are subject to change. Parameters marked typical are illustrative; they are indications of typical performance and will vary with each unit we manufacture. Unless stated otherwise, all specifications are measured at 450 nm.
- <sup>2)</sup> Hands-free tuning range is from 210 nm to 2600 nm. Wavelengths values at margins are rounded.
- <sup>3)</sup> Measured at 450 nm. See tuning curves for typical outputs at other wavelengths.
- <sup>4)</sup> Measured at 230 nm. See tuning curves for typical outputs at other wavelengths.
- <sup>5)</sup> Measured at the peak of tuning curve. See tuning curves for typical outputs at other wavelengths.
- <sup>6)</sup> FWHM measured with photodiode featuring 1 ns rise time and 300 MHz bandwidth oscilloscope.
- <sup>7)</sup> In signal and idler range. Linewidth is <5 cm<sup>-1</sup> for 210 – 480 nm range.
- <sup>8)</sup> Beam diameter is measured at 450 nm at the 1/e<sup>2</sup> level and can vary depending on the pump pulse energy.
- <sup>9)</sup> Beam pointing stability is evaluated as movement of the beam centroid in the focal plane of a focusing element.
- <sup>10)</sup> Laser output will be optimized for OPO operation and specifications may vary with each unit we manufacture.
- <sup>11)</sup> Starting from 22 °C and stand-by mode.
- <sup>12)</sup> Air cooled. Water cooled under request.

Note: The laser and auxiliary units must be settled in such a place void of dust and aerosols. It is advisable to operate the laser in air conditioned room, provided that the laser is placed at a distance from air conditioning outlets. The laser should be positioned on a solid and flat worktable in horizontal position. Access from one side should be ensured. Intensive sources of vibration should be avoided near the laboratory (ex. railway station or similar).



**OPTIONS**

Option	Features
-SH/SF	Tuning range extension in 210 – 405 nm range by combining second harmonics and sum-frequency generator outputs for maximum possible pulse energy
-DUV	Deep UV option for 192 – 210 nm range output
-FC	Fiber coupled output in 350 – 2000 nm range
-ATTN	Attenuator output in 210 – 2600 nm range
-SCU	Spectral filtering accessory for improved spectral purity of pulses

**PERFORMANCE**

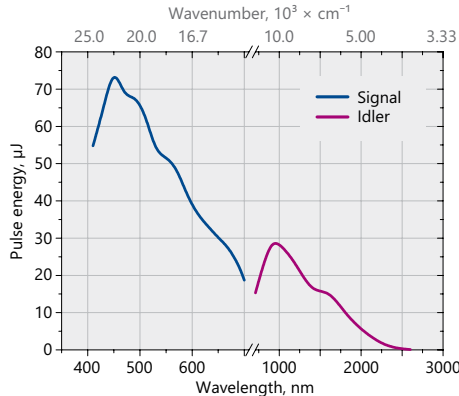

Fig 1. Typical (smoothed) NT262 laser tuning curves in signal (405 – 710 nm), idler (710 – 2600 nm) ranges

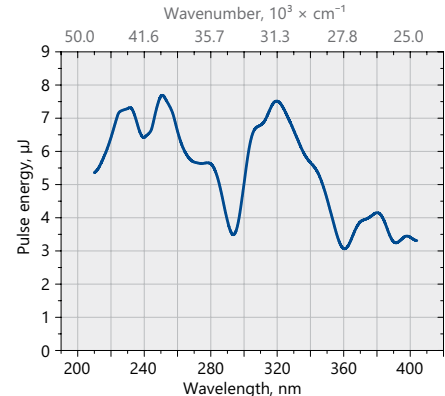

Fig 2. Typical (smoothed) NT262 laser output with -SH/SF option (210 – 405 nm) range

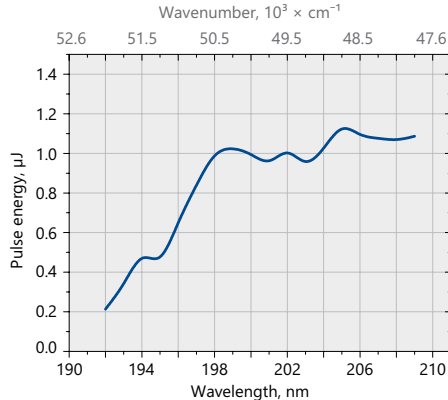

Fig 3. Typical (smoothed) NT262 laser output with -DUV option (192 – 210 nm) range

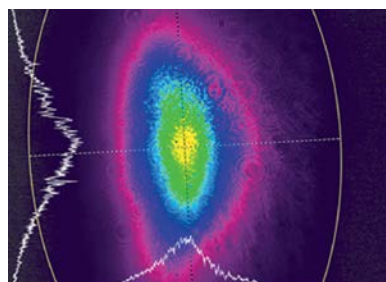

Fig 4. NT262 series laser beam profile at 450 nm in near field

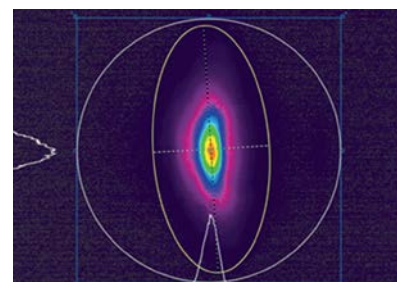

Fig 5. NT262 series laser beam profile at 450 nm in far field

**OUTLINE DRAWINGS**



Fig 5. For easier transportation and integration NT262 features removable handles

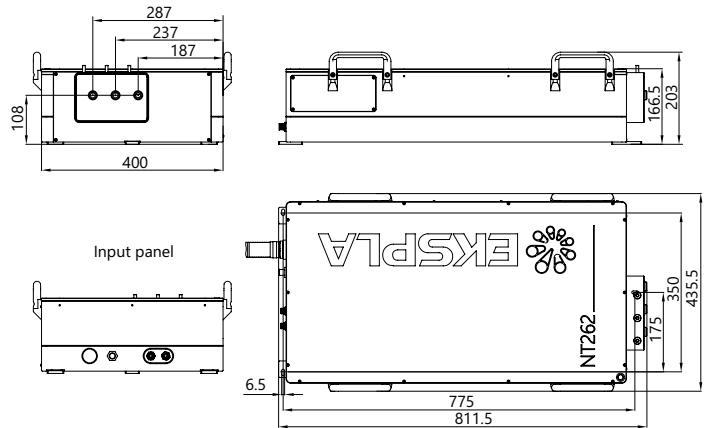
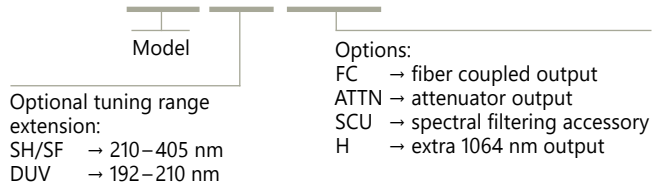

Fig 6. NT262 series laser head dimensions (without options)

**ORDERING INFORMATION**

**Note:** Laser must be connected to the mains electricity all the time. If there will be no mains electricity for longer than 1 hour then laser (system) needs warm up for a few hours before switching on.

**NT262-SH/SF-FC-ATTN**



[www.phototechnica.co.jp](http://www.phototechnica.co.jp)  
 フォトテクニカ株式会社  
 〒336-0017 埼玉県さいたま市南区南浦和 2-18-2  
 TEL:048-871-0067 FAX:048-871-0068  
 e-mail:voc@phototechnica.co.jp