

# ORPHEUS-F

## Broad Bandwidth Hybrid Optical Parametric Amplifier



### FEATURES

- Combines the best features of collinear and non-collinear OPA
- <100 fs pulse duration
- Variable bandwidth
- Single pulse – 1 MHz repetition rate
- Computer controlled
- Dual pulse width option provides gap free tunability (650 – 2500 nm)

ORPHEUS-F is a hybrid optical parametric amplifier of white-light continuum pumped by femtosecond Ytterbium based laser amplifiers. This OPA combines the short pulse durations that are produced by a non-collinear OPA and wide wavelength tuning range (620 – 900 nm) offered by collinear OPA. The Signal beam can be easily compressed with a simple prism-based setup down to <60 fs in most of the tuning range, while Idler is compressed in bulk material down to 40 – 90 fs depending on wavelength. Switching to standard OPA configuration for tuning in 900 – 1200 nm range (250 fs) is optional. It possible to limit the output

bandwidth to some extent (up to 2 – 3 times) without losing any output power.

Standard ORPHEUS device uses spectral narrowing to produce bandwidth-limited 200 – 300 fs duration pulses directly at the output, with extended Signal/Idler tuning range and options to generate ultraviolet and mid-infrared light. Our non-collinear ORPHEUS-N-2H device produces even broader bandwidths, compressible down to <20 fs, but limits the tuning range to 650 – 900 nm. For most applications, the performance of ORPHEUS-F configuration is the optimal choice.

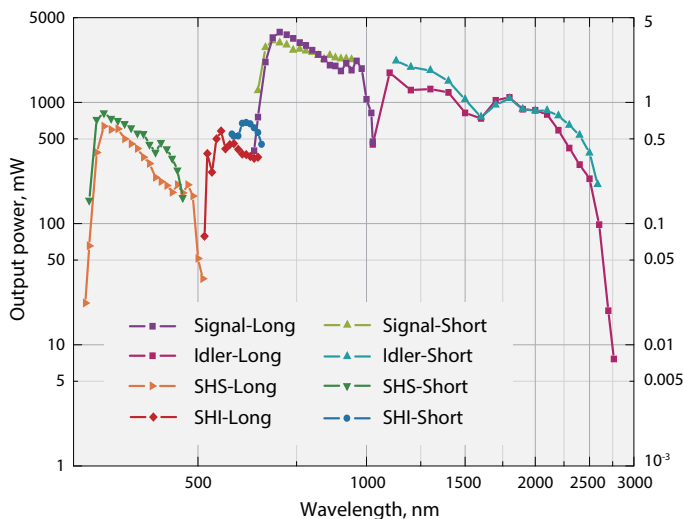

### ORPHEUS-F

ORPHEUS-F energy conversion curve.  
Pump: 40 W, 40  $\mu$ J, 1000 kHz

For custom tuning curve value visit  
<http://toolbox.lightcon.com/tools/tuningcurves/>

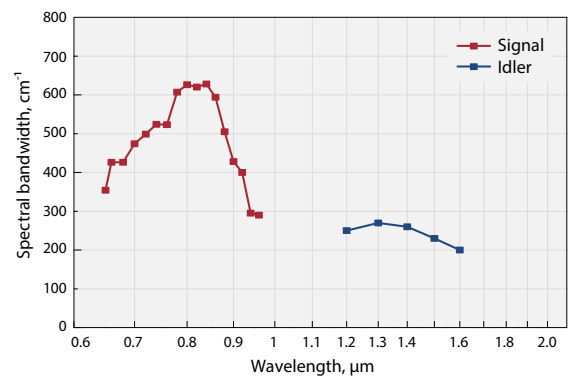

Typical spectral bandwidth of ORPHEUS-F

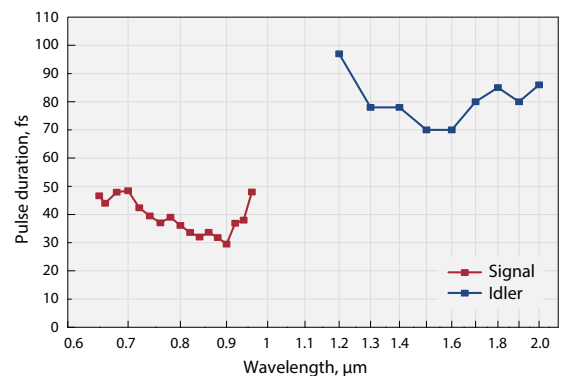

Pulse duration after compression of ORPHEUS-F

**SPECIFICATIONS**

Product name	<i>ORPHEUS-F</i> [short pulse mode]	<i>ORPHEUS-F</i> [long pulse mode]
--------------	--	---------------------------------------

OUTPUT FROM ORPHEUS-F

Tuning range	Signal	650 – 900 nm	650 – 1010 nm
	Idler	1 200 – 2 500 nm	1050 – 2 500 nm
Integrated second harmonic generation efficiency		> 35 % (515 nm) <sup>1)</sup>	
Pump power (maximum)		Up to 40 W	
Pump energy		10 – 500 μJ	
Conversion efficiency at peak, Signal + Idler combined		> 10 %	
Pulse duration before compression		< 290 fs	
Pulse bandwidth	650 – 900 nm	200 – 750 cm <sup>-1</sup>	80 – 150 cm <sup>-1</sup> (PHAROS / CARBIDE) 100 – 220 cm <sup>-1</sup> (PHAROS-SP)
	800 – 900 nm	< 55 fs	—
Pulse duration after compressor	650 – 800 nm	< 70 fs	
	1200 – 2000 nm	< 100 fs	
	Typical: 650 – 900 nm	25 – 70 fs	
	Typical: 1200 – 2000 nm	40 – 100 fs	
Compressor transmission	650 – 900 nm	> 65 %	—
	1200 – 2000 nm	> 80 %	
Long term power stability (8 h)		< 2 % @ 800 nm	
Pulse energy stability (1 min)		< 2 % @ 800 nm	

WAVELENGTH EXTENSIONS

At peak	325 – 450 nm (SH of Signal)	> 1 %	—
	325 – 505 nm (SH of Signal)	—	> 1 %
	525 – 650 nm (SH of Idler)	—	> 0.5 %
	600 – 700 nm (SH of Idler)	> 0.5 %	—
	210 – 252 nm (FH of Signal)	—	> 0.1 %
	263 – 325 nm (FH of Idler)	—	> 0.2 %
	2200 – 4200 nm (DFG1)	Contact Light Conversion	
	4000 – 16000 nm (DFG2)	Contact Light Conversion	

<sup>1)</sup> At designated output port.

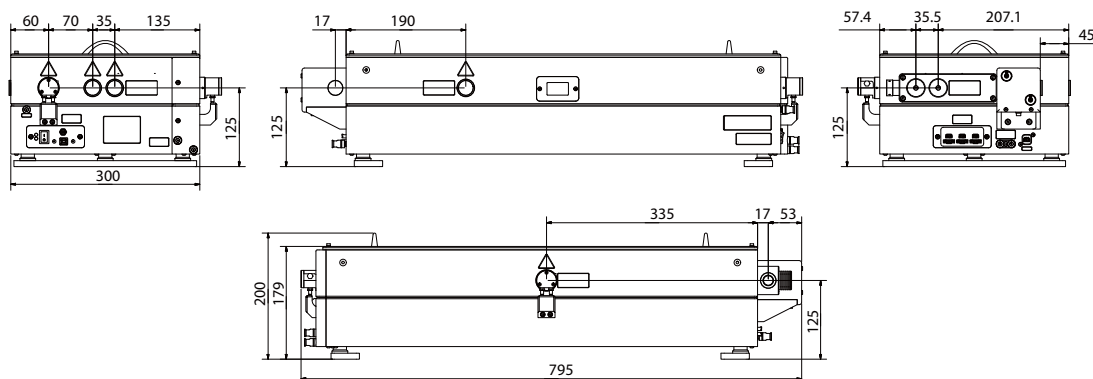

ORPHEUS-F outline drawings