

Quantas

Q1-1064

DIODE PUMPED AIR-COOLED Q-SWITCHED Nd:YAG LASER

FEATURES

Up to **32 mJ** pulse energy at **1064 nm**

Air cooled – no liquids inside

Short pulse duration **< 8 ns**

Weight is **< 5 kg** incl. power supply

Variable up to **50 Hz** repetition rate

Build-in sync pulse generator for triggering of user equipment

Remote control via build-in **Ethernet** interface

Optional 2nd, 3rd, 4th or 5th harmonic generators

Optional attenuator for fundamental wavelength

Optional fiber coupled output

OEM version is available

Guaranteed **> 1 Gshot** lifetime

APPLICATIONS

Light Induced Breakdown Spectroscopy (LIBS)

Laser ablation

Time-of-Flight Spectroscopy (TOFS)

Light Induced Fluorescence (LIF) spectroscopy

Flash photolysis

Matrix Assisted Laser Desorption/Ionization (MALDI)

Pulsed Light Deposition (PLD)

Light Detection and Ranging (LIDAR)

Remote sensing

TFT-LCD repair

Particle Image Velocimetry (PIV)



Quantas is diode pumped, air-cooled, Q-switched laser designed for wide range of applications that require low pulse repetition rate and high peak power pulses (Q1D model produces ~5 MW peak power). Due good thermal properties of Nd:YAG crystal Q1-1064 can operate at higher pulse repetition rates in comparison to Q1-1053. Laser can produce up to 30 mJ at 20 Hz repetition rate or up to 10 mJ at 50 Hz repetition rate. Typical applications are Light Induced Breakdown Spectroscopy (LIBS), Light Induced Fluorescence Spectroscopy (LIF), laser ablation and remote sensing. Less than 8 ns pulse duration allows efficient fundamental wavelength conversion to higher harmonics with shortest wavelength available of 213 nm. Wavelength extensions into infrared range are available by request.

Quantas is completely air cooled laser due its excellent wall-plug efficiency. Liquids are not used for heat transfer, as result, maintenance associated with regular replacements of cooling liquid and/or cleaning of cooling system is not required.

Low jitter triggering pulses for user equipment are available with up to 300 μ s lead in internal triggering mode. If required, laser pulsing can be externally triggered from delay generator, allowing operation in single-shot or variable pulse repetition modes.

Laser controller has Ethernet interface for convenient monitoring and control from personal computer.



Quantum
Light
Instruments

WWW.QLINSTRUMENTS.COM

SPECIFICATIONS ¹⁾

MODEL	Quantas-1064 Q1B	Quantas-1064 Q1C	Quantas-1064 Q1D
Wavelength		1064 nm ²⁾	
Pulse energy	10 mJ	18 / 16 mJ ³⁾	32 / 30 mJ ³⁾
Typical pulse duration		< 8 ns ⁴⁾	
Pulse to pulse energy stability ⁵⁾		< 0.5 % RMS	
Power drift		± 3.0 % ⁶⁾	
Pulse repetition rate ⁷⁾			
Min		single shot	
Max	10, 20 or 50 Hz	10 or 20 Hz	10 or 20 Hz
Beam profile	nearly TEM ₀₀	bell-shaped, > 75 % fit to Gaussian	
Beam divergence ⁸⁾	< 2 mrad	< 1.5 mrad	
Polarization	linear, horizontal at 1064 nm		
Typical beam diameter, ⁹⁾	1.5 mm	2 mm	2.5 mm
Jitter	< 1 ns RMS ¹⁰⁾		

OPTIONAL HARMONICS GENERATOR MODULE ¹¹⁾

Pulse energy			
532 nm	5 mJ	9 / 8 mJ	16 / 15 mJ
355 nm	3 mJ	5.5 / 5 mJ	9.5 / 9 mJ
266 nm	1.5 mJ	3 / 2.5 mJ	5 / 4 mJ
213 nm	0.5 mJ	1.2 / 1 mJ	2 / 1.6 mJ

OPTIONAL ATTENUATOR ¹²⁾

Wavelength, nm	1064 nm, 532 nm, 355 nm
Attenuation range	5 – 95 %

OPTIONAL FIBER COUPLED OUTPUT ¹³⁾

Wavelength	1064 or 532 nm
Max output pulse energy	up to 7 mJ ¹⁴⁾

DIMENSIONS

Laser head (W×L×H)	113 × 230 × 112 mm ³
Harmonics generator module (W×L×H)	113 × 242 × 112 mm ³
Controller unit (W×L×H)	85 × 165 × 50 mm ³
Power adapter, typical (W×L×H)	50 × 125 × 32 mm ³

OPERATING REQUIREMENTS

Cooling requirements	air cooled
Ambient temperature	15 – 30 °C
Relative humidity	10 – 80 % (non-condensing)
Mains voltage	90 – 230 V AC, single phase, 47 – 63 Hz ¹⁵⁾
Power consumption	< 30 W

¹⁾ Due to continuous improvements all specifications are subject to change. Unless stated otherwise all specifications are measured at 1064 nm and 10 Hz pulse repetition rate.

²⁾ 1053 nm output wavelength models are available. See Q1-1053 model leaflet.

³⁾ First number is for 10 Hz, second – for 20 Hz pulse repetition rate.

⁴⁾ FWHM level at 1064 nm. Shorter pulse duration is available by request. Inquire for detailed specifications.

⁵⁾ Averaged from 500 pulses.

⁶⁾ Over 8 hour period after 20 minutes of warm-up when ambient temperature variation is less than ±2 °C.

⁷⁾ Factory-set pulse repetition rate is fixed at max repetition rate. Single-shot or variable pulse repetition rate is possible when laser is externally triggered. Higher repetition rates are available, please inquire for details.

⁸⁾ Full angle measured at 1/e² level.

⁹⁾ Beam diameter is measured 20 cm from laser output at 1/e² level.

¹⁰⁾ In respect to Q-switch triggering edge of pulse.

¹¹⁾ Harmonics generator module is stand-alone unit optimized for specified output wavelength. Inquire for details if multiple wavelength output is needed.

¹²⁾ External Motorized Variable Attenuator. Please inquire for attenuator build-in into harmonics generator module.

¹³⁾ Fiber coupler is build-in into harmonics generator module. Please inquire for details.

¹⁴⁾ For fiber core diameter of 550 μm. Smaller or larger core fibers are available, inquire for specifications.

¹⁵⁾ Laser can be powered from appropriate 12 V DC power source. Inquire for details.



DRAWINGS

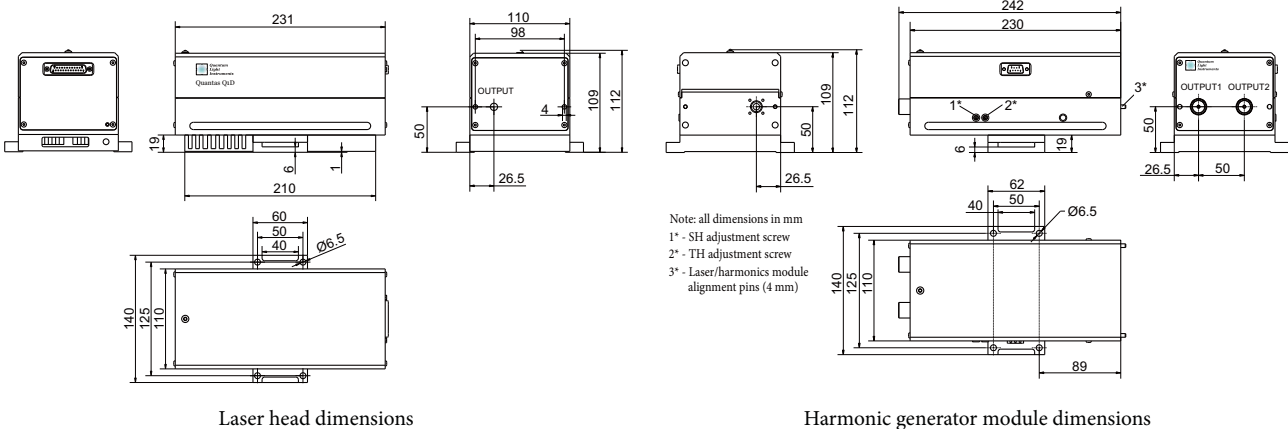

Laser head dimensions

Harmonics generator module dimensions