

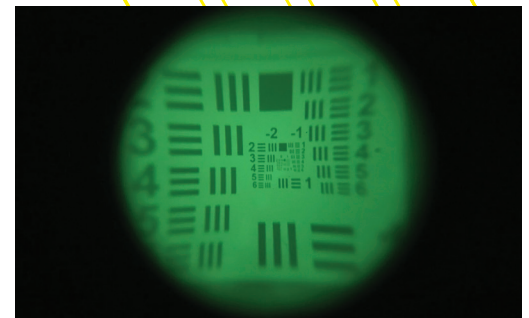

ABRIS SERIES

Converts 350-2000nm
radiation to visible

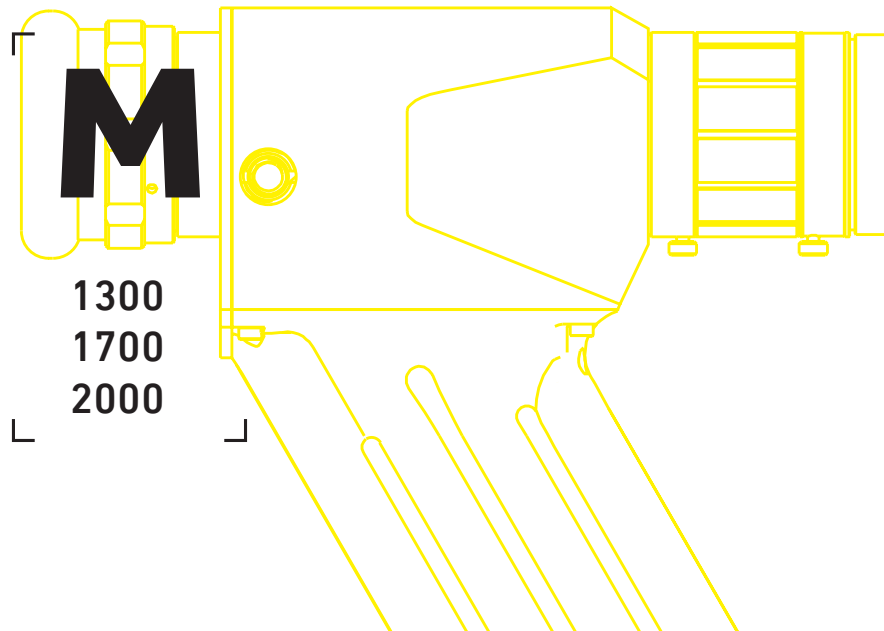

APPLICATIONS:

- Location and alignment of Nd:YAG Yb:YAG, Yb:KGW, Ti:Sapphire and other IR lasers
- Identification of stray IR reflections
- Observation of GaAs laser diodes, IR LED's, dye and other IR-sources
- Forensic analysis on inks, pigments

MAIN FEATURES:

- Wide spectral region 350 - 2000 nm
- Lightweight and ergonomic design
- High contrast
- High sensitivity
- Excellent image quality
- Hand-held / post mounted
- Works with C-mount lenses (with adapter)
- Charged via USB
- Pulsed and CW light detection without synchronisation
- Connects to PC via video adapter
- Interfaces to CCTV cameras



How does it work?

Infrared viewer focus emitted or reflected light from a chosen subject into the image tube where electron image is generated. When powered (with battery or power supply) the 16-18 kV voltage is generated required to accelerate the electron image into the output phosphor screen. The fluorescent green light output (550 nm) is observed via an adjustable eyepiece lens.

Accessories available

- Neutral density filter to lens 1X (3-5%@1064 nm)
- Neutral density filter to lens 2X (3-5%@1064 nm)
- Microscope adapter
- Facemask for hands free operation
- IR illuminator 850 nm
- C-mount Camera adapter
- Lens 2X (F1.8/50 mm)
- Lens 1X (F1.4/25 mm)
- Distance ring
- Video adapter VA-1

< SPECTRAL SENSITIVITY

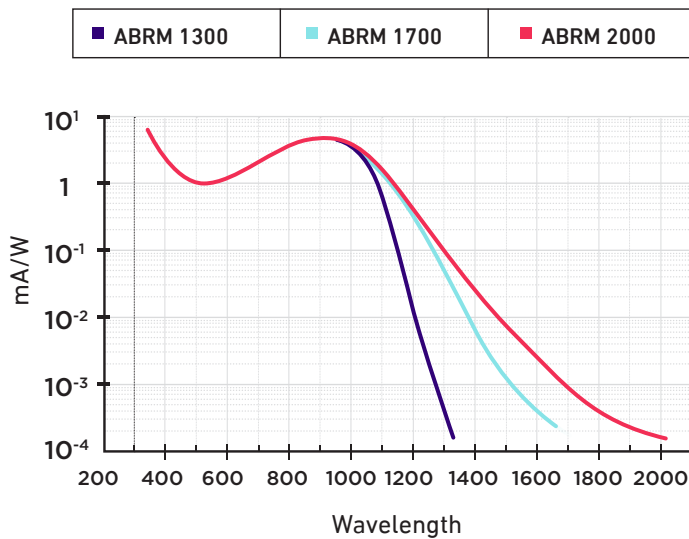

< POWER DENSITY

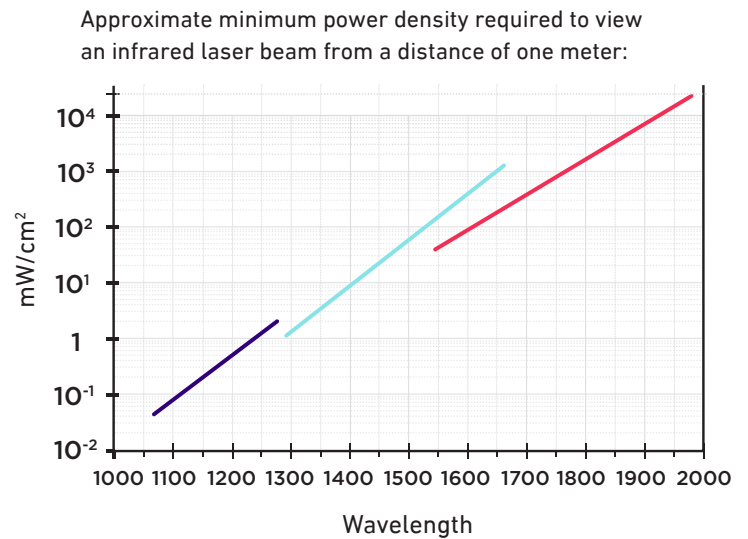

TECHNICAL INFORMATION

	MODEL 1X	MODEL 2X
< SPECTRAL RANGE	ABRM-1300-x (350-1300 nm) ABRM-1700-x (350-1700 nm) ABRM-2000-x (350-2000 nm)	
FIELD OF VIEW	40°	20°
MAGNIFICATION	1X	2X
FOCUS	0.1 m to ∞	0.5 m (0.15m)* to ∞
Objective lens	F1.4/25 mm	F1.8/50 mm
Resolution (center)	60 Lp/mm	
Adjustable iris	Included	
Distortion of image	20%	
Battery life fully charged	50 hours	
Weight	0.4 kg	
Dimensions	153x184x51 mm	
Tripod or handle	R1/4"	

* with macro ring