

## BLAZER series

Medium-power industrial ps-laser



*BLAZER series provide industrial grade DPSS picoseconds lasers with adjustable repetition rate and high peak power. Rugged and compact design of these lasers has been a versatile tool for a variety of industrial material processing applications.*

### FEATURES

- 10-40W at 1064nm / Harmonics from 532nm to 355nm
- 100-2000 kHz repetition rate / 10 ps pulse duration
- High beam quality  $M^2 < 1.3$
- Compact, sealed and rugged industrial grade design
- Fully detachable umbilical
- Burst mode
- Integrated process shutter
- PSO

### APPLICATIONS

- Cutting and drilling for Materials such as glass, sapphire
- Thin film ablation
- Micromachining
- Patterning

### BLAZER-20F/40F Laser Head Mechanical Specifications

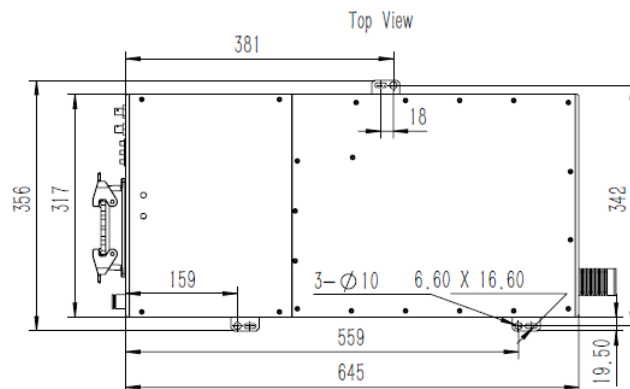
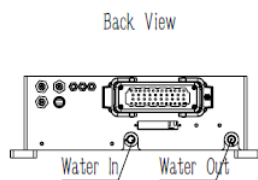
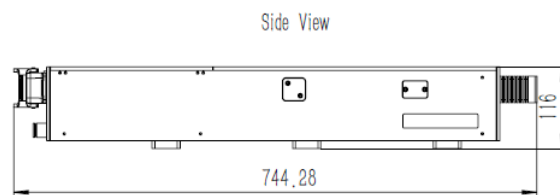
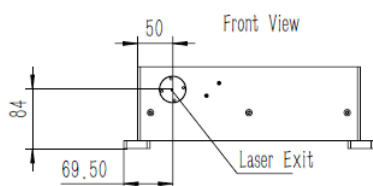

# BLAZER series Specifications



Medium-power industrial ps-laser

## Beam characteristics

Version	BLAZER-20F			BLAZER-40F		
Wavelength (nm)	1064nm (532/355 option)					
Repetition Rate <sup>1</sup> (kHz)	100 – 2000 kHz					
Average Power (W)	Average Power (W) at Different Rep. Rates <sup>2</sup>					
Wavelength (nm)	100kHz	500kHz	800kHz	400kHz	600kHz	800kHz
1064nm	13	24	26	35	40	40
532nm <sup>3</sup>	8	15	18	20	25	25
355nm	5	10	10	12	15	15
Pulse Energy (μJ)	Pulse Energy (μJ) at Different Rep. Rates					
Wavelength (nm)	100kHz	500kHz	800kHz	400kHz	600kHz	800kHz
1064nm	130	48	32.5	87.5	66.6	50
532nm	80	30	22.5	50	41.6	31
355nm	50	20	12.5	30	25	18.8
Beam Spatial Profile	TEM <sub>00</sub> (M <sup>2</sup> <1.3)					
Pulsewidth FWHM (ps)	<15ps@1064nm					
Energy Stability (RMS)	<2%					
Power Stability <sup>4</sup> (RMS)	<2%					
Polarization Ratio	>100:1					
Beam Circularity (%)	>85%					
Pointing Stability <sup>5</sup> (μrad/°C)	<50μrad/°C					
Beam Divergence <sup>6</sup> (mrad)	<1mrad					
Beam Diameter <sup>7</sup> (mm)	~2mm					

## General characteristics

AC Input	220 VAC ±5% 50-60Hz
Power Consumption	<2.5kW (typical 50W at 500kHz)
Cooling Type	Closed-loop water cooling
Operating Conditions	Temperature 15-35°C Humidity <65%
Warm-Up Time (mins)	<40mins

### NOTES

- 1.All specifications at 1064nm and 500kHz repetition rate unless otherwise noted.
- 2.Please provide operating Rep. rate for optimum output power.
- 3.A lower 532nm output power version to be offered if need both 532nm &355nm.
- 4.Average in 8 hours with room temperature variation  $\delta T < 3^{\circ}C$ .
- 5.Maximum deviation from beam mean centroid.
6. Full angle for 86.5% of energy.
- 7.Output of laser head at 1064nm.



### China

#### Grace Laser Technology Co., Ltd.

Ju Hong BLDG B, Area B, Airport Industrial Park, Shunyi District, Beijing, China

Postcode: 101318

Tel: +86 010-60401920 Fax: +86 010-60401720 Email: sales@gracelaser.com

Web: www.gracelaser.com

PHOTO  
TECHNICA www.phototechnica.co.jp  
フォトテクニカ株式会社  
〒336-0017 埼玉県さいたま市南区南浦和 1-2-17  
TEL:048-871-0067 FAX:048-871-0068  
e-mail:voc@phototechnica.co.jp

## BLAZER series

High-power industrial ps-laser



*BLAZER series provide industrial grade DPSS picoseconds lasers with adjustable repetition rate and high peak power. Rugged and compact design of these lasers has been a versatile tool for a variety of industrial material processing applications.*

### FEATURES

- 30-100W at 1064nm / Harmonics from 532nm to 355nm
- 100-2000 kHz repetition rate / 10 ps pulse duration
- High beam quality  $M^2 < 1.3$
- Compact, sealed and rugged industrial grade design
- Fully detachable umbilical
- Burst mode
- Integrated process shutter
- PSO

### APPLICATIONS

- Cutting and drilling for Materials such as PI, FPC, LCP
- Thin film ablation
- Micromachining
- Patterning

### BLAZER-50F/100F Laser Head Mechanical Specifications

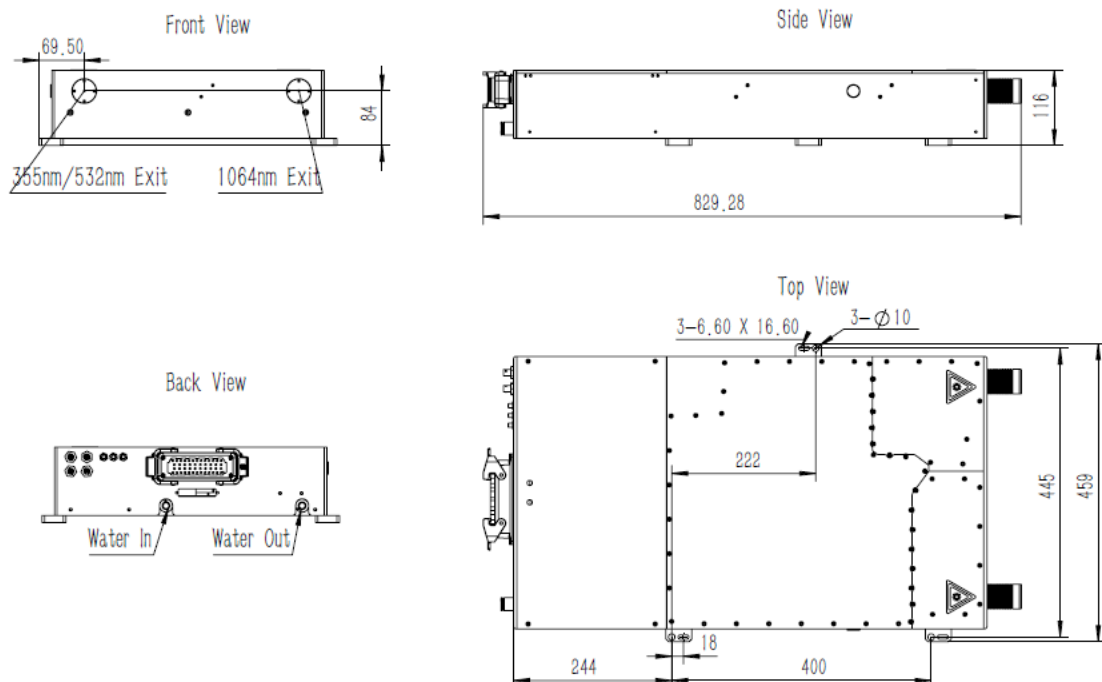

# BLAZER series Specifications



High-power industrial ps-laser

## Beam characteristics

Version	BLAZER-50F			BLAZER-100F		
Wavelength (nm)	1064nm (532/355 option)					
Repetition Rate <sup>1</sup> (kHz)	100 – 2000 kHz					
Average Power (W)	Average Power (W) at Different Rep. Rates <sup>2</sup>					
Wavelength (nm)	100kHz	500kHz	800kHz	400kHz	600kHz	800kHz
1064nm	30	50	50	70	80	80
532nm <sup>3</sup>	18	30	25	50	50	50
355nm	12	20	20	30	30	30
Pulse Energy (μJ)	Pulse Energy (μJ) at Different Rep. Rates					
Wavelength (nm)	100kHz	500kHz	800kHz	400kHz	600kHz	800kHz
1064nm	300	100	62.5	175	133	100
532nm	180	60	31	125	83	62.5
355nm	120	40	25	75	50	37.5
Beam Spatial Profile	TEM <sub>00</sub> (M <sup>2</sup> <1.3)					
Pulsewidth FWHM (ps)	<10ps@1064nm					
Energy Stability (RMS)	<2%					
Power Stability <sup>4</sup> (RMS)	<2%					
Polarization Ratio	>100:1					
Beam Circularity (%)	>85%					
Pointing Stability <sup>5</sup> (μrad/°C)	<50μrad/°C					
Beam Divergence <sup>6</sup> (mrad)	<1mrad					
Beam Diameter <sup>7</sup> (mm)	~2mm					

## General characteristics

AC Input	220 VAC ±5% 50-60Hz
Power Consumption	<2.5kW (typical 50W at 500kHz)
Cooling Type	Closed-loop water cooling
Operating Conditions	Temperature 15-35°C Humidity <65%
Warm-Up Time (mins)	<40mins

### NOTES

- 1.All specifications at 1064nm and 500kHz repetition rate unless otherwise noted.
- 2.Please provide operating Rep. rate for optimum output power.
- 3.A lower 532nm output power version to be offered if need both 532nm &355nm.
- 4.Average in 8 hours with room temperature variation  $\delta T < 3^{\circ}\text{C}$ .
- 5.Maximum deviation from beam mean centroid.
6. Full angle for 86.5% of energy.
- 7.Output of laser head at 1064nm.



### China

#### Grace Laser Technology Co., Ltd.

Ju Hong BLDG B, Area B, Airport Industrial Park, Shunyi District, Beijing, China  
 Postcode: 101318  
 Tel: +86 10-60401920 Fax: +86 10-60401720 Email: sales@gracelaser.com  
 Web: www.gracelaser.com

**PHOTO TECHNICA** www.phototechnica.co.jp  
**フォトテクニカ株式会社**  
 〒336-0017 埼玉県さいたま市南区南浦和 1-2-17  
 TEL:048-871-0067 FAX:048-871-0068  
 e-mail:voc@phototechnica.co.jp