

# NT230 SERIES

## High Energy Broadly Tunable DPSS Lasers



NT230 series lasers deliver high up to 9 mJ energy pulses at 100 Hz pulse repetition rate, tunable over a broad spectral range. Integrated into a single compact housing, the diode pumped Q-switched Nd:YAG laser and Optical Parametric Oscillator (OPO) offers hands-free, no-gap tuning from 193 to 2600 nm. With its 100 Hz repetition rate, the NT230 series laser establishes itself as a versatile tool for many laboratory applications, as laser induced fluorescence, flash photolysis, photobiology, metrology, remote sensing, etc.

Due to the innovative diode-pumped design, NT230 series lasers features maintenance-free laser operation for an extended period of time and

improved stability (compared with flash-lamp pumped counterparts).

NT230 series systems can be controlled from a remote control pad or/and a computer using supplied LabVIEW™ drivers. The control pad allows easy control of all parameters and features on a backlit system display that is easy to read even with laser safety eyewear.

Due to DPSS pump source, the laser requires little maintenance. It is cooled by a water-air chiller, which further reduces running costs. An OPO pump energy monitor allows monitoring of pump laser performance. A standard feature includes a separate output port for the 355 nm pump beam.

### FEATURES

- ▶ Integrates DPSS pump laser and OPO into a single housing
- ▶ Hands-free no-gap wavelength tuning from 192 to 2600 nm
- ▶ High, up to 15 mJ pulse energy from OPO
- ▶ 100 Hz pulse repetition rate
- ▶ More than 2 mJ output pulse energy in UV
- ▶ Less than 5 cm<sup>-1</sup> linewidth
- ▶ 2–5 ns pulse duration
- ▶ Remote control pad
- ▶ PC control via USB port (RS232 is optional) and LabVIEW™ drivers
- ▶ Optional separate output port for 532/1064 nm beam

### APPLICATIONS

- ▶ Laser-induced fluorescence
- ▶ Flash photolysis
- ▶ Photobiology
- ▶ Remote sensing
- ▶ Metrology
- ▶ Non-linear spectroscopy

### Accessories and optional items

Option	Features
-SH	Tuning range extension in UV range (210–405 nm) by second harmonic generation
-SF	Tuning range extension in 300–405 nm range by sum-frequency generation
-SH/SF	Tuning range extension in 210–405 nm range by combining second harmonic and sum-frequency generator outputs for maximum possible pulse energy
-DUV	Deep UV option in 192–210 nm
-H, -2H	1064 nm or 532 nm output via separate port
-FC	Fiber coupled output in 300–2000 nm range
-Attn/FC	Fiber coupled attenuated output
-SCU	Spectral filtering accessory for improved spectral purity of pulses

**SPECIFICATIONS <sup>1)</sup>**

Model	NT230-50	NT230-100
<b>OPO</b>		
Wavelength range		
Signal	405 – 710 nm	
Idler	710 – 2600 nm	
SH and SF	210 – 405 nm <sup>2)</sup>	
DUV	192 – 210 nm	
Pulse energy <sup>3)</sup>		
OPO	15 mJ	9 mJ
SH and SF <sup>4)</sup>	2 mJ	1.5 mJ
DUV	0.3 mJ	0.2 mJ
Pulse repetition rate	50 Hz	100 Hz
Pulse duration <sup>5)</sup>	2 – 5 ns	
Linewidth <sup>6)</sup>	<5 cm <sup>-1</sup>	
Tuning resolution <sup>7)</sup>		
Signal	1 cm <sup>-1</sup>	
Idler	1 cm <sup>-1</sup>	
SH/SF/DUV	2 cm <sup>-1</sup>	
Polarization		
Signal	horizontal	
Idler	vertical	
SH/SF	horizontal	
DUV	vertical	
OPO beam divergence <sup>8)</sup>	<2 mrad	
Typical beam diameter <sup>9)</sup>	4 mm	
<b>PUMP LASER</b>		
Pump wavelength <sup>10)</sup>	355 nm	
Typical pump pulse energy <sup>11)</sup>	50 mJ	35 mJ
Pulse duration <sup>6)</sup>	4 – 6 ns at 1064 nm	
<b>PHYSICAL CHARACTERISTICS</b>		
Unit size (W × L × H)	451 × 640 × 152 mm	
Power supply size (W × L × H)	471 × 391 × 147 mm	
External chiller	inquire	
Umbilical length	2.5 m	
<b>OPERATING REQUIREMENTS</b>		
Cooling	external chiller	
Room temperature	15 – 30 °C	
Relative humidity	20 – 80 % (non-condensing)	
Power requirements	208 or 240 V AC, single phase 50/60 Hz	
Power consumption	<1 kVA	

<sup>1)</sup> Due to continuous improvement, all specifications are subject to change. Parameters marked typical are illustrative. They are indications of typical performance and will vary with each unit we manufacture. Unless stated otherwise, all specifications are measured at 450 nm.

<sup>2)</sup> Separate –SH and –SF options are available.

<sup>3)</sup> See tuning curves for typical outputs at other wavelengths.

<sup>4)</sup> Measured at 260 nm and 340 nm wavelengths

<sup>5)</sup> FWHM measured with photodiode featuring 1 ns rise time and 300 MHz bandwidth oscilloscope.

<sup>6)</sup> Linewidth is <8 cm<sup>-1</sup> for 210 – 405 nm range.

<sup>7)</sup> When wavelength is controlled from PC. When wavelength is controlled from keypad, tuning resolution is 0.1 nm for signal, 1 nm for idler and 0.05 nm for SH, SF and DUV.

<sup>8)</sup> Full angle measured at the FWHM level at 450 nm.

<sup>9)</sup> Beam diameter is measured at 450 nm at the 1/e<sup>2</sup> level and can vary depending on the pump pulse energy.

<sup>10)</sup> Separate output port for the 3rd harmonic beam is standard. Output ports for other harmonic are optional.

<sup>11)</sup> The pump laser pulse energy will be optimized for best OPO performance and can vary with each unit we manufacture.



PERFORMANCE

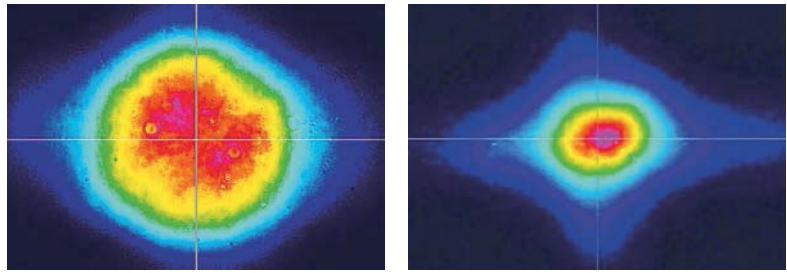

Near field Far field

Fig 1. Typical beam profiles of NT230 series lasers at 450 nm

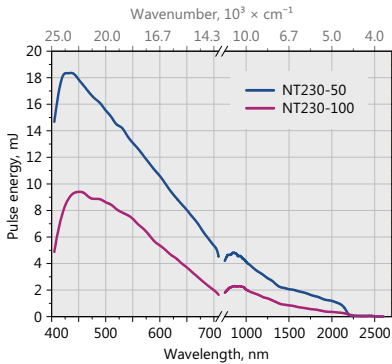

Fig 2. Typical output pulse energy of NT230 laser

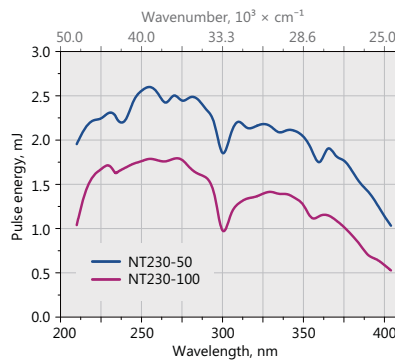

Fig 3. Typical output pulse energy of NT230 laser with SH/SF extension

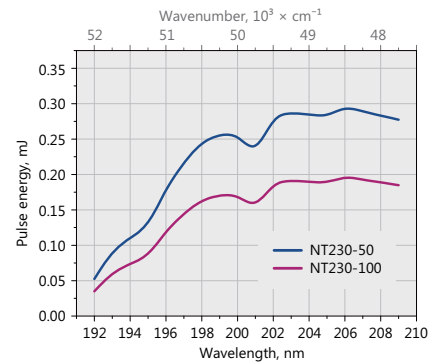

Fig 4. Typical output pulse energy of NT230 laser with DUV extension

OUTLINE DRAWINGS

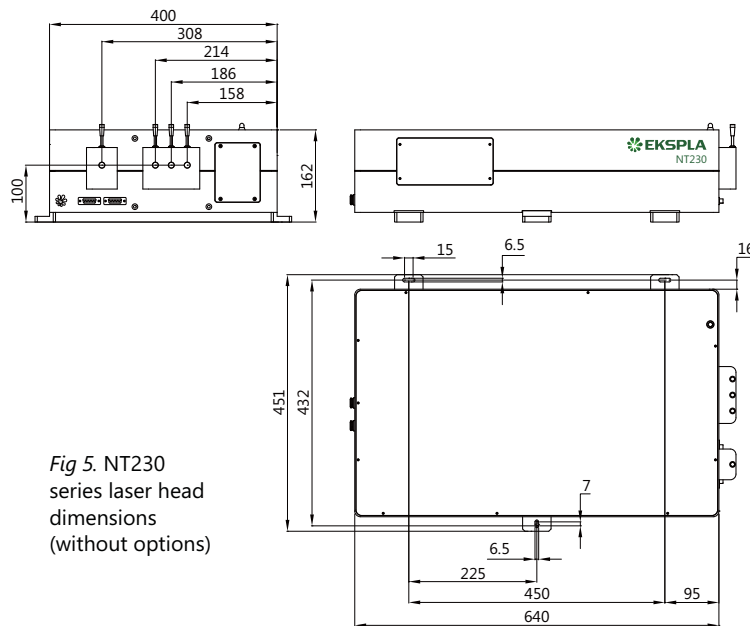

Fig 5. NT230 series laser head dimensions (without options)

ORDERING INFORMATION

**Note:** Laser must be connected to the mains electricity all the time. If there will be no mains electricity for longer than 1 hour then laser (system) needs warm up for a few hours before switching on.

NT230-50-SH-H-2H-SCU

<p>Model</p> <p>Pulse repetition rate in Hz</p>	<p>Options:</p> <p>H → extra 1064 nm output</p> <p>2H → extra 532 nm output</p> <p>SCU → spectral filtering accessory</p> <p>Optional tuning range extension:</p> <p>SH → 210–405 nm</p> <p>SF → 300–405 nm</p> <p>SH/SF → 210–405 nm</p> <p>DUV → 192–210 nm</p>
-------------------------------------------------	-------------------------------------------------------------------------------------------------------------------------------------------------------------------------------------------------------------------------------------------------------------------