

# PL2210 SERIES



PL2210 series diode-pumped, air-cooled, mode-locked Nd:YAG lasers provide picosecond pulses at a kilohertz pulse repetition rate.

Short pulse duration, excellent pulse-to-pulse stability, superior beam quality makes PL2210 series diode pumped picosecond lasers well suited for many applications, including material processing, time-resolved spectroscopy, optical parametric generator pumping, and other tasks.

### Flexible design

PL2210 series lasers offer a number of optional items that extend the capabilities of the laser. A pulse picker option allows control of the pulse repetition rate of the laser and operation in single-shot mode.

The repetition rate and timing of pulses can be locked to an external RF source (with –PLL option) or other ultrafast laser system (with –FS option). The laser provides a triggering pulse for synchronization of the customer’s equipment. A low jitter SYNC OUT pulse has a lead up to 500 ns that can be adjusted in ~0.25 ns steps from a PC. Up to 400 μs lead of triggering pulse is available as a PRETRIG feature that is designed to provide precise, very low jitter trigger pulses for a streak camera.

### Built-in harmonic generators

Motorised switching of wavelength for PL2210A. Non-linear crystals mounted in temperature stabilized heaters are used for second, third and fourth high spectral purity harmonic generation.

### Available models <sup>1)</sup>

Model	Features
PL2210A-1k	Up to 900 μJ, 28 ps pulses at an up to 1 kHz repetition rate
PL2211A	Up to 5 mJ energy at a 1 kHz repetition rate at 28 ps pulses

<sup>1)</sup> Custom-built models with higher pulse energy are available on request.

## Diode Pumped Picosecond kHz Pulsed Nd:YAG Lasers

### FEATURES

- ▶ High pulse energy at kHz rates
- ▶ Diode pumped **solid state** design
- ▶ **Air cooled** – external water supply is not required (for PL2210A-1k only)
- ▶ Turn-key operation
- ▶ Low maintenance costs
- ▶ Optional streak camera triggering pulse with <10 ps rms jitter
- ▶ Remote control pad
- ▶ PC control
- ▶ Optional temperature stabilized second, third and fourth **harmonic generators**

### APPLICATIONS

- ▶ Time resolved fluorescence (including streak camera measurements), pump-probe spectroscopy
- ▶ OPG/OPA/OPO pumping
- ▶ Remote Laser Sensing
- ▶ Other spectroscopic and nonlinear optics applications

### Simple and convenient laser control

For customer convenience the laser can be operated from master device or personal computer through USB (VCP, ASCII commands), RS232 (ASCII commands), LAN (REST API) or RS232 (ASCII commands), LAN (REST API) depending on the system configuration or from remote control pad with backlit display that is easy to read even while wearing laser safety glasses.

**SPECIFICATIONS <sup>1)</sup>**

Model	PL2210A	PL2211A
<b>Output energy</b>		
at 1064 nm	0.9 mJ	5 mJ
at 532 nm <sup>2)</sup>	0.45 mJ	2.5 mJ
at 355 nm <sup>3)</sup>	0.35 mJ	1.6 mJ
at 266 nm <sup>4)</sup>	0.16 mJ	1 mJ
<b>Pulse energy stability (StdDev) <sup>5)</sup></b>		
at 1064 nm	0.5 %	
at 532 nm	0.8 %	
at 355 nm	1 %	
at 266 nm	2 %	
Pulse duration (FWHM) <sup>6)</sup>	29 ± 4 ps	
Pulse repetition rate	1 kHz	
Triggering mode	internal/external	
Typical TRIG1 OUT pulse delay <sup>8)</sup>	-500 ... 50 ns	
TRIG1 OUT pulse jitter	< 0.1 ns rms	
Spatial mode <sup>9)</sup>	Close to Gaussian	
Beam divergence <sup>10)</sup>	<1 mrad	
Beam diameter <sup>11)</sup>	1.7 ± 0.3 mm	~3 mm
Beam pointing stability <sup>12)</sup>	< 30 µrad	
Pre-pulse contrast	> 200 : 1	
Polarization	linear, >100 : 1	
<b>PHYSICAL CHARACTERISTICS</b>		
Laser head size (W × L × H) <sup>13)</sup>	456 × 1031 × 249 mm	
Power supply size (W × L × H)	365 × 392 × 290 mm	550 × 600 × 550 ±3 mm (19" standard, MR-9)
<b>OPERATING REQUIREMENTS</b>		
Water service	not required, air cooled	
Relative humidity	20–80 % (non condensing)	
Ambient temperature	22 ± 2 °C	
Power requirements	100–240 V AC, single phase 50/60 Hz	
Power consumption <sup>14)</sup>	<1 kW	<1.5 kW

<sup>1)</sup> Due to continuous improvement, all specifications are subject to change without notice. Parameters marked typical are not specifications. They are indications of typical performance and will vary with each unit we manufacture. Unless stated otherwise, all specifications are measured at 1064 nm and for basic system without options.

<sup>2)</sup> For PL2210 series laser with -SH, -SH/TH, -SH/FH or -SH/TH/FH option. Outputs are not simultaneous.

<sup>3)</sup> For PL2210 series laser with -TH, -SH/TH or -SH/TH/FH option. Outputs are not simultaneous.

<sup>4)</sup> For PL2210 series laser with -SH/FH or -SH/TH/FH option. Outputs are not simultaneous.

<sup>5)</sup> Averaged from pulses, emitted during 30 sec time interval.

<sup>6)</sup> Optional 80 or 22 ps ± 10% duration. Pulse energy specifications may differ from indicated here.

<sup>7)</sup> With respect to optical pulse. <10 ps rms jitter is provided optionally with PRETRIG feature.

<sup>8)</sup> TRIG1 OUT lead or delay can be adjusted with 0.25 ns steps in specified range.

<sup>9)</sup> Near field Gaussian fit is >90%.

<sup>10)</sup> Average of X- and Y-plane full angle divergence values measured at the 1/e<sup>2</sup> level at 1064 nm.

<sup>11)</sup> Beam diameter is measured at 1064 nm at the 1/e<sup>2</sup> point.

<sup>12)</sup> Beam pointing stability is evaluated from fluctuations of beam centroid position in the far field.

<sup>13)</sup> 456×1233×249 mm (W×L×H) laser head size might be required for some optional configurations.

<sup>14)</sup> At 1 kHz pulse repetition rate.



OPTIONS

- ▶ **PRETRIG** provides low jitter pulse for streak camera triggering with lead/delay in -400...600  $\mu$ s range and <10 ps rms jitter.
- ▶ **Option P80** provides 80 ps  $\pm$  10 % output pulse duration. Inquire for pulse energy specifications.
- ▶ **Option P20** provides 22 ps  $\pm$  10 % output pulse duration. Inquire for pulse energy specifications.
- ▶ **Option PC** allows reduction of the pulse repetition rate of the PL2210 series laser by integer numbers. Single shot mode is also possible. In addition, the -PC option reduces the low-intensity quasi-CW background that is present at laser output at 1064 nm wavelength. Please note that the output of fundamental wavelength and harmonic will be reduced by approx. 20% with installation of the -PC option.

BEAM PROFILE

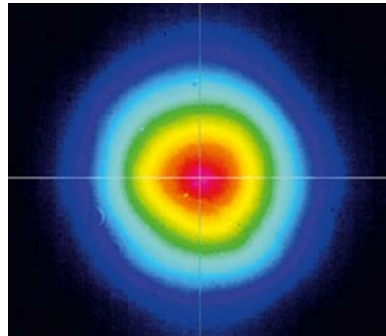

Fig 1. Typical PL2210 series laser near field beam profile at 1064 nm except PL2211A

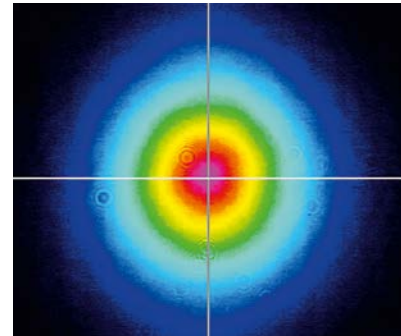

Fig 2. Typical PL2211A laser near field beam profile at 1064 nm

OUTLINE DRAWINGS

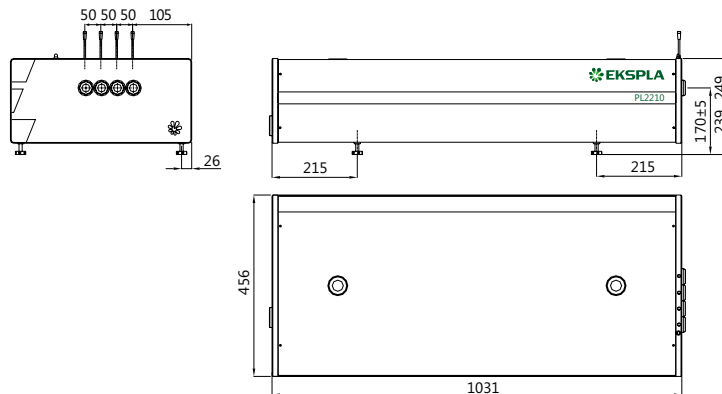

Fig 3. Dimensions of PL2210 series laser head

ORDERING INFORMATION

**Note:** Laser must be connected to the mains electricity all the time. If there will be no mains electricity for longer than 1 hour then laser (system) needs warm up for a few hours before switching on.

