

SL230 SERIES



SL230 series lasers are excellent solution for applications, where high energy picosecond pulses are needed. Not like conventional mode-locked lasers that typically uses saturable nonlinear absorption or Kerr lensing to produce ultrafast pulses, the SL230 series lasers employ backward-stimulated Brillouin scattering (SBS) in liquid for the same purpose.

Innovative design

Diode pumped electro-optically Q-switched single longitudinal mode (SLM) nanosecond generator is the heart of the system. It provides nanosecond optical pulse that is later compressed during SBS in a special cell.

Q-switched master oscillator allows precise external triggering with jitter of less than 0.2 ns rms while mode-locked lasers typically have jitters of at least of tens of nanoseconds or even worse. Precise sync pulses from internal delay generator are also available with less than 200 ps rms jitter with respect to optical pulse.

Pulse compression is done in SBS-cell. The geometry of interaction is designed to produce shortest and most stable pulses with 120 ps duration.

After SBS compression, pulse is directed to multi-pass flashlamp pumped power amplifier for amplification to up to 500 mJ pulse energy.

Completely diode pumped version of SL231 is available under special request.

Thermocontrolled harmonic generators, based on angle-tuned KD*P and KDP crystals and harmonic separation optics are available as standard options. Each wavelength has a separate output port.

Build in energy monitors continuously monitors output pulse energy. Data from the energy monitor can be seen on the remote keypad or on PC screen.

Power supply and cooling units are mounted into standard 19" rack.

Simple and convenient laser control

Laser is controlled by PC via USB port with application for Windows™ operating system.

In addition, major settings of laser can be controlled through remote control pad. The remote pad features a backlit display that is easy to read even while wearing laser safety eyewear.

SBS Compressed Picosecond DPSS Nd:YAG Lasers

FEATURES

- ▶ Diode pumped Q-switched SLM master oscillator
- ▶ Flashlamp pumped power amplifier for up to **500 mJ** pulse energy at 1064 nm
- ▶ Advanced SBS compression produces pulses down to **120 ps** duration
- ▶ Excellent pre-pulse contrast ratio
- ▶ Thermo stabilized second, third or fourth harmonic generator options
- ▶ Low jitter external triggering
- ▶ Sync pulses output with < 200 ps rms jitter
- ▶ Laser control from PC via USB or RS232 port
- ▶ Low maintenance costs

APPLICATIONS

- ▶ Plasma research
- ▶ Medical
- ▶ Material ablation and deposition
- ▶ Interferometry
- ▶ Remote laser sensing
- ▶ Satellite ranging



SPECIFICATIONS ¹⁾

Model	SL231 ²⁾	SL234	SL235
Max. pulse energy:			
at 1064 nm	20 mJ	250 mJ	500 mJ
at 532 nm ³⁾	8 mJ	125 mJ	240 mJ
at 355 nm ⁴⁾	5 mJ	70 mJ	140 mJ
at 266 nm ⁵⁾	2 mJ	40 mJ	80 mJ
at 213 nm ⁶⁾	inquire		
Pulse energy stability (StdDev): ⁷⁾			
at 1064 nm	2 %		1.5 %
at 532 nm	3.5 %		3 %
at 355 nm	5 %		4 %
at 266 nm	8 %		7 %
at 213 nm	inquire		
Pulse duration at 1064 nm (FWHM) ⁸⁾	120 ps ± 15 %		150 ps ± 15 %
Pulse duration stability at 1064 nm (StdDev) ⁷⁾	5 %		
Repetition rate	50 Hz	10 Hz	5 Hz
Linewidth	≤ 0.2 cm ⁻¹		
Polarization ratio at 1064 nm	> 1:100		
Optical pulse jitter (StdDev) ⁹⁾	0.2 ns		
Beam profile	near Gaussian	Top Hat ¹⁰⁾	
Beam pointing stability at 1064 nm ¹¹⁾	< 50 μrad		
Beam divergence ¹²⁾	< 0.5 mrad		
Beam height	170±5 mm		
Contrast ratio	≥ 10 ⁵ : 1		
Beam diameter ¹³⁾	~ 4 mm	~ 10 mm	~ 12 mm

PHYSICAL CHARACTERISTICS

Laser head size (W × L × H)	456 × 810 × 249 mm	456 × 1031 × 249 mm	
Electric cabinet size (W × L × H)	553 × 600 × 519 mm		553 × 600 × 665 mm
Umbilical length	2.5 m		

OPERATING REQUIREMENTS

Water consumption (max. 20 °C)	< 10 liters/min		
Room temperature	18–24 °C		
Relative humidity	10–80 % (non-condensing)		
Power requirements	208 or 380 V AC, three phase, 50/60 Hz	208 or 230 V AC, single phase, 50/60 Hz	
Power consumption	< 2 kVA	< 3.5 kVA	< 4 kVA

- ¹⁾ Due to continuous improvement, all specifications are subject to change. Parameters marked typical are illustrative. They are indications of typical performance and will vary with each unit we manufacture. Unless stated otherwise all specifications are measured at 1064 nm and for basic system without options.
- ²⁾ Completely diode pumped version of SL231 is available under special request.
- ³⁾ For -SH option. Outputs are not simultaneous. Please inquire for pulse energies at other wavelengths.
- ⁴⁾ For -TH option. Outputs are not simultaneous. Please inquire for pulse energies at other wavelengths.
- ⁵⁾ For -FH option. Outputs are not simultaneous. Please inquire for pulse energies at other wavelengths.

- ⁶⁾ For custom -FIH option. Outputs are not simultaneous. Please inquire for pulse energies at other wavelengths.
- ⁷⁾ Averaged from 300 pulses.
- ⁸⁾ Inquire for optional variable pulse durations in 150 – 400 ps or 400 – 1000 ps range (does not apply for SL231). Some of laser specifications with this option may differ from those without it.
- ⁹⁾ In external triggering mode with two separate triggering pulses for flashlamps and Q-switch.
- ¹⁰⁾ Near Gaussian fit profile with lower energy is available by request.
- ¹¹⁾ RMS value measured from 300 shots. Beam pointing stability is evaluated from fluctuations of beam centroid position in the far field.
- ¹²⁾ Full angle measured at the 1/e² point at 1064 nm.
- ¹³⁾ Beam diameter is measured at 1064 nm at the 1/e² level.



OPTIONS

► Variable pulse duration options -VPx and -VPCx

SL series lasers offer a unique capability for tuning pulse duration. The tuning is done by changing the geometry of interaction in the SBS compressor. Two tuning ranges – 120–500 ps (option -VP1) and 500–1000 ps (option -VP2) – are available as standard options.

While the -VPx option requires manual tuning of optical layout components for pulse duration change, the -VPCx option provides motorized tuning that allows a change in pulse duration from a personal computer (purchased separately) or laser control pad.

Note. Certain specifications may change when the laser is configured for variable pulse duration. Contact Ekspla for detailed data sheets.

OUTLINE DRAWINGS

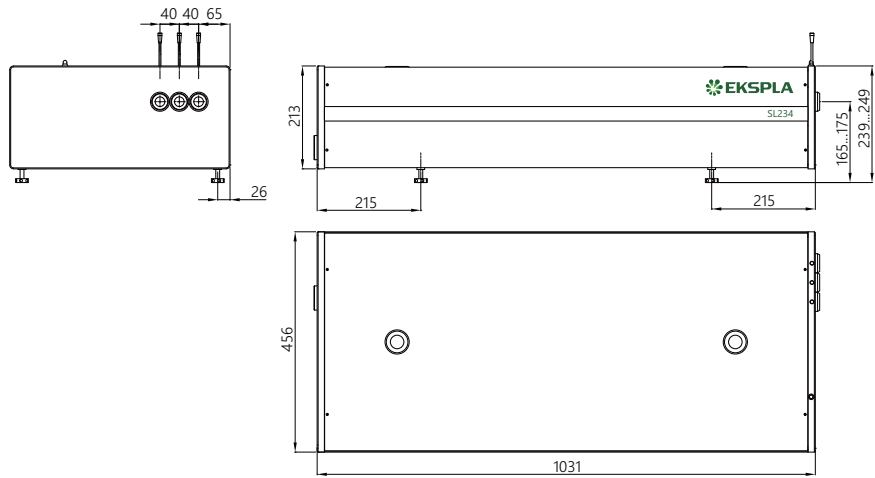

Fig 1. SL234, SL235 lasers head outline drawing

Note: Laser must be connected to the mains electricity all the time. If there will be no mains electricity for longer than 1 hour then laser (system) needs warm up for a few hours before switching on.

Femtosecond Lasers

Picosecond Lasers

Picosecond Tunable Systems

Nanosecond Lasers

Nanosecond Tunable Lasers

High Energy Lasers

Other Ekspla Products