

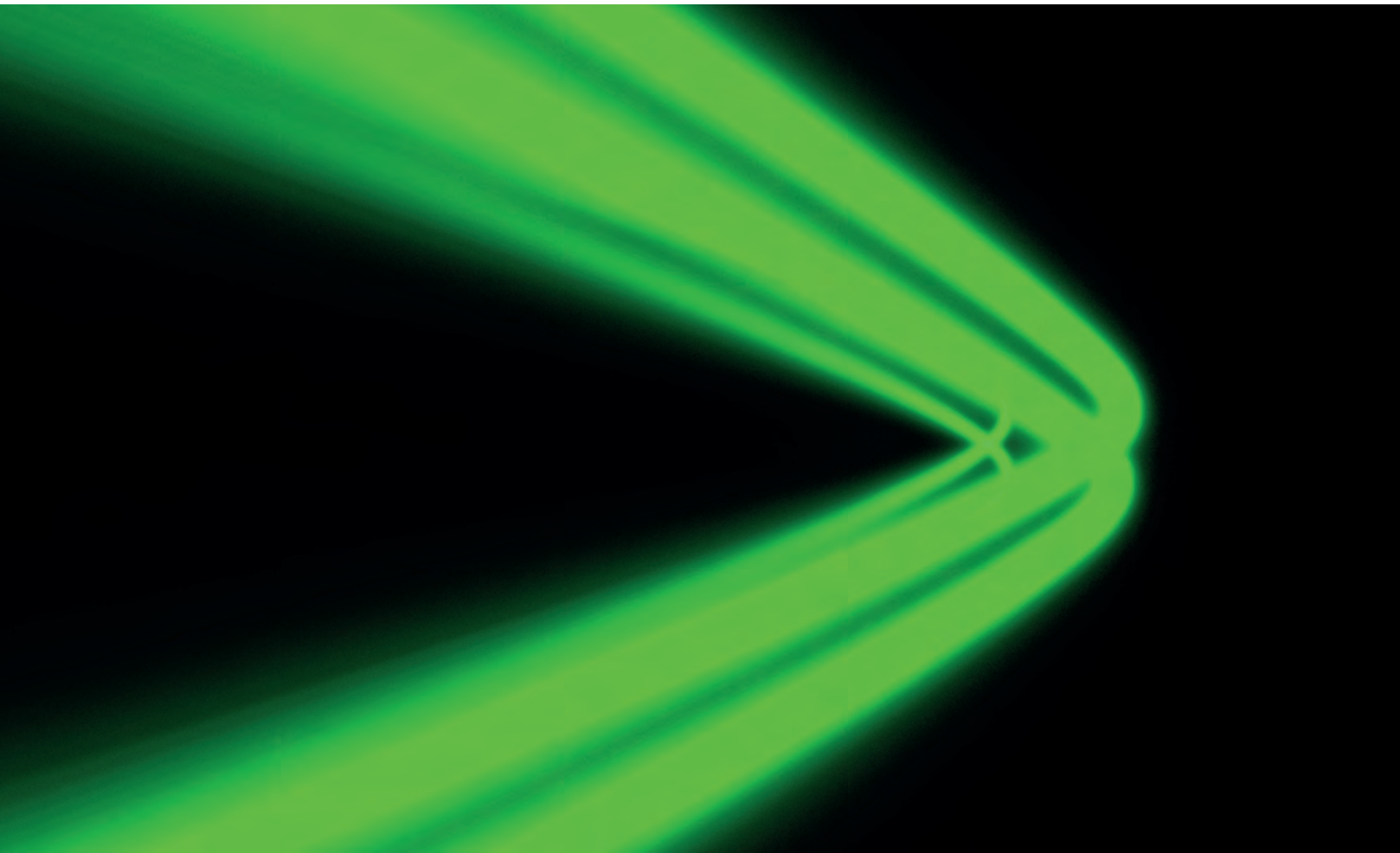

# 190 nm (6.5 eV) Laser-ARPES

Laser ARPES using a Tunable ps UV Source



# 190 nm (6.5 eV) UV Source

## Laser ARPES/ARUPS with a High-Power UV Source

- Tunable deep-UV pulses from 190 ... 215 nm (6.5 ... 5.77 eV) are available with APE's wavelength conversion instruments: HarmoniXX in combination with Levante Emerald.
- The tunable system provides high laser power in the range of several mW. Its brilliant and monochromatic laser light is ideally suited for high-resolution ARPES (Angle-resolved Photoemission Spectroscopy) or ARUPS (Angle-resolved Ultraviolet Photoemission Spectroscopy).



- Tunable (Vacuum)-UV wavelengths from 190 ... 215 nm / 6.5 ... 5.77 eV
- Extremely narrow spectral bandwidth of  $< 0.2$  meV
- High photon flux of  $> 10^{15}$  photons/s
- Exceptional beam quality of  $M^2 < 1.2$
- Automated wavelength tuning via software
- Ideally suited for table-top laser-based ARPES / ARUPS

# Laser-based ARPES Application

## Laser-based ARPES

- Laser-based Angle-Resolved Photo-Emission Spectroscopy is a form of ARPES that uses a laser as excitation source. Compared to synchrotron light source, laser-based ARPES offers some advantages:

It fits on a table and makes experiment schedules independent from rare beam times at synchrotron facilities. The UV-laser generates an ultra-high energy resolution of down to 0.1 meV while providing a very high photon flux. For measurements, the bulk sensitivity is enhanced and the momentum resolution increased by using low energy photons of around 6 eV. This photon energy is sufficient to induce photoemission in many samples. However, due to the lower photon energy - compared to synchrotron radiation - Laser-ARPES is limited to probe electronic states close to the Fermi level.

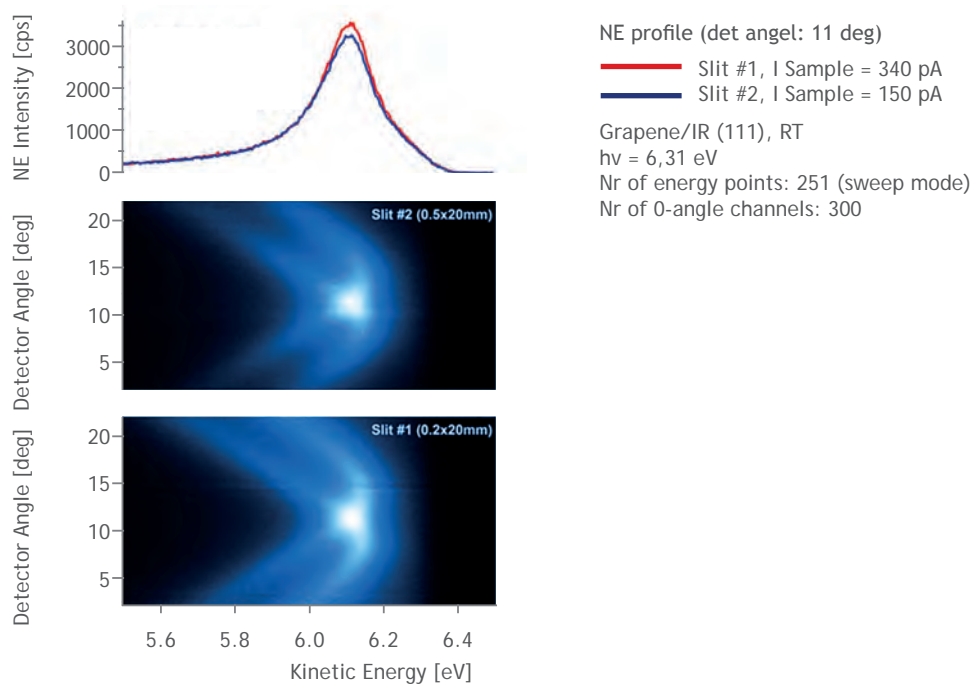

## Comparison of a Table-top ARPES Source versus Synchrotron Radiation

	UV Laser-based	Synchrotron Light Source
■ Energy resolution	0.16 meV	5 - 20 meV
■ Photon flux	$> 10^{15}$ photons/s	$< 10^{13}$ photons/s
■ Photon energy	5.77 - 6.5 eV	5 - 1000 eV
■ Momentum region	about 1 BZ	$> 5$ BZ
■ Bulk Sensitivity	3 - 10 nm	5 - 20 nm
■ Tunable	Yes	Yes
■ Measurement	Fermi-level	All

# 190 nm (6.5 eV) Turn-Key

## Creating a 190 nm (6.5 eV) Table-top System

- This light source enables spectroscopy and pump probe measurements in the deep UV range < 200 nm. The system consists of the following sub-components:

### Levante Emerald HP OPO

- The generation of high power tunable UV radiation is based on a widely tunable picosecond OPO (Optical Parametric Oscillator) with computer controlled tuning, pumped by an industrial high power green laser and with subsequent frequency conversion to reach UV wavelengths even below 200 nm (> 6.20 eV).

### HarmoniXX FHG

- The signal beam of Levante Emerald HP pumps the Fourth Harmonic Generator HarmoniXX FHG (3+1) in order to achieve 190 nm emission.
- The HarmoniXX FHG (3+1) allows access to the wavelength range < 190 ... 215 nm (6.5 ... 5.77 eV) by mixing the THG with the fundamental wavelength to create the fourth harmonic. The harmonic pulses are narrow bandwidth, enabling high resolution across the tuning range.

### Pump Laser

- Paladin 532 - 20000 from Coherent Inc. is ideal for pumping OPOs. It is enabling a wide tuning-range and high-average powers of the OPO output. Of course, also other pump lasers can be incorporated into the setup.

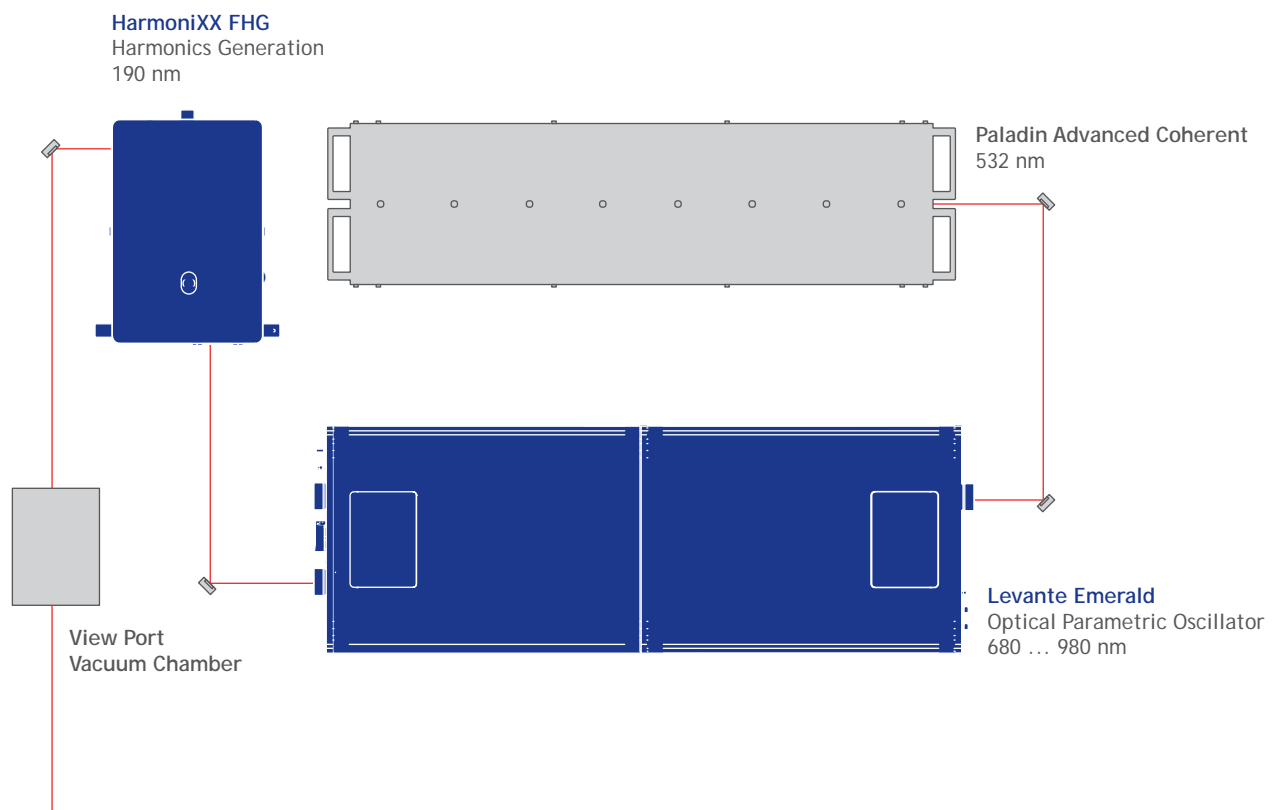

# ARPES on Graphene/Ir(111)

## ARPES on Graphene/Ir(111)

- The following measurements are performed with APE's 190 nm (6.5 eV) system. The ARPES data are taken with a PHOIBOS 150 hemispherical analyzer with 2D-CCD detector (SPECS GmbH).

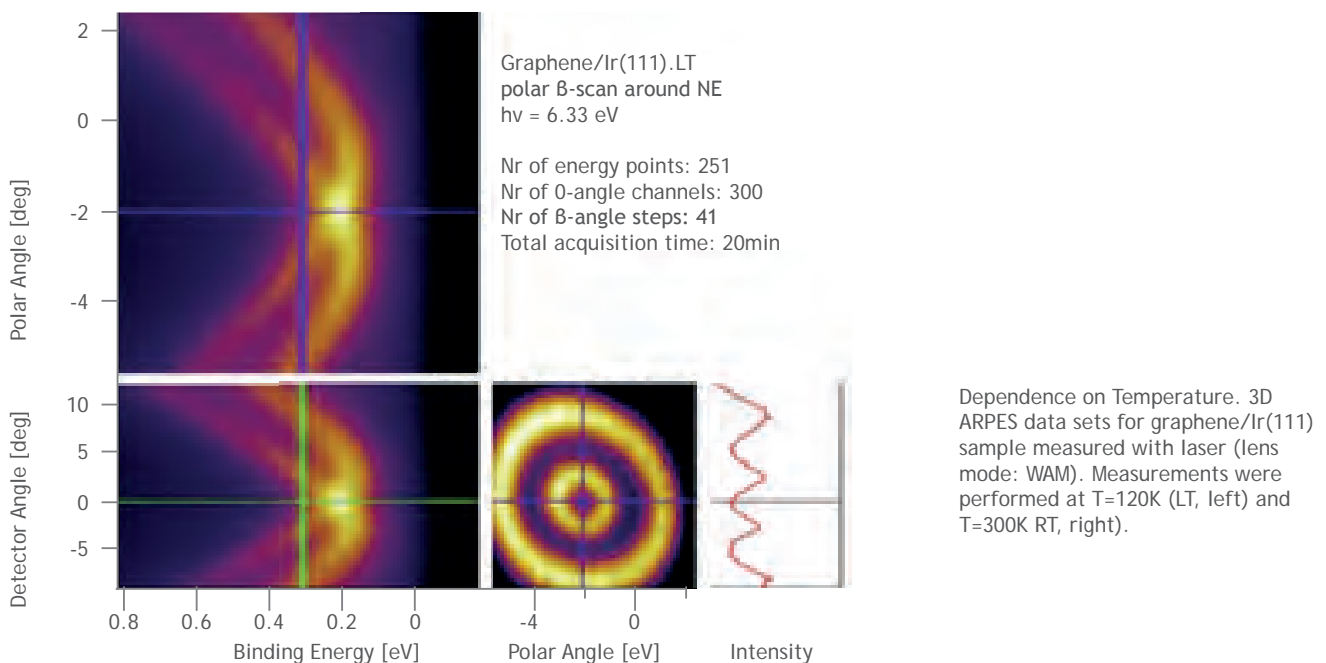
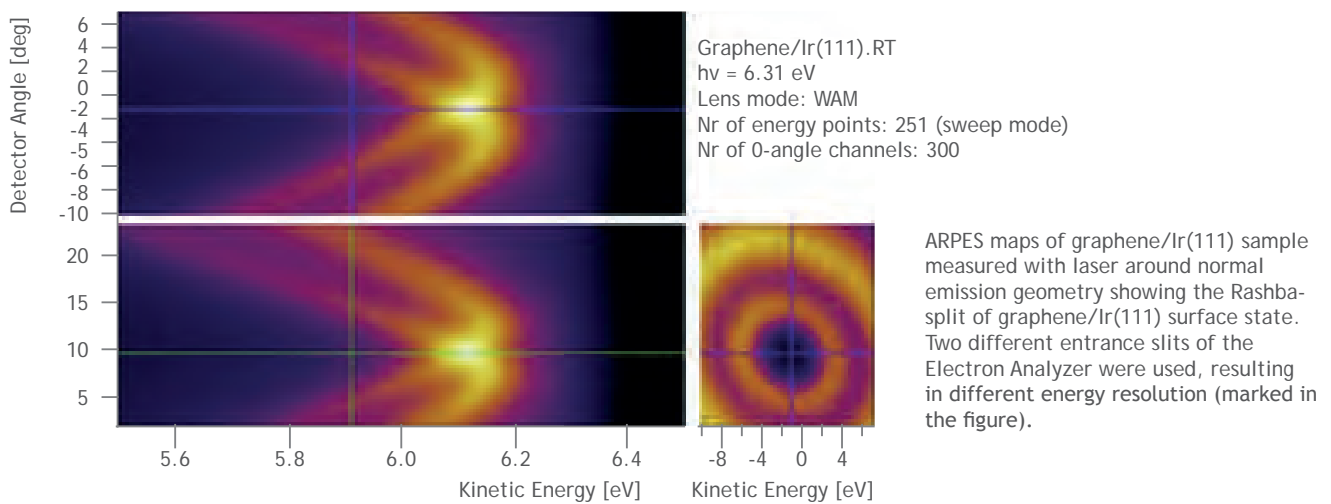

- Measurements by Thorsten Kampen, SPECS Nano Surface Analysis GmbH, Berlin. A full application report is available from APE.

# 190 nm / 6.5 eV UV Laser Specifications



## Levante Emerald HP + HarmoniXX FHG (incl. THG, SHG)

Wavelength Range	< 192 ... 215 nm   > 6.5 ... 5.77 eV (FHG) < 240 ... 320 nm   > 5.12 ... 3.87 eV (THG) < 360 ... 480 nm   > 3.44 ... 2.58 eV (SHG) < 690 ... 990 nm (Levante Emerald HP OPO Signal)
Power Output	> 11 mW at 207 nm   6 eV (FHG) > 75 mW at 280 nm   4.4 eV (THG) > 410 mW at 800 nm   1.55 eV (SHG; THG components removed) > 6000 mW at 760 ... 960 nm (OPO Signal)
Pulse Width	Approx. 15 ps
Spectral Bandwidth FHG	5 pm   0.16 meV at 196 nm   6.46 eV
Repetition Rate	80 MHz
M2	< 1.2 (typical 1.1)
Polarization	Linear / Horizontal

## Pump Laser

Wavelength	532 nm
Power	> 20 W
Pulse Width	Approx. 15 ps
Manufacturer	Coherent Inc. (Paladin 532-20000)

## Software

Software	Included
Remote Control	Possible via USB / Ethernet TCP/IP / Serial RS232

## Dimensions

Dimensions	See drawings
------------	--------------



DANGER  
LASER RADIATION  
AVOID EYE OR SKIN EXPOSURE TO  
DIRECT OR SCATTERED RADIATION  
CLASS 4 LASER PRODUCT

# ... Technical Drawings

## Levante Emerald HP

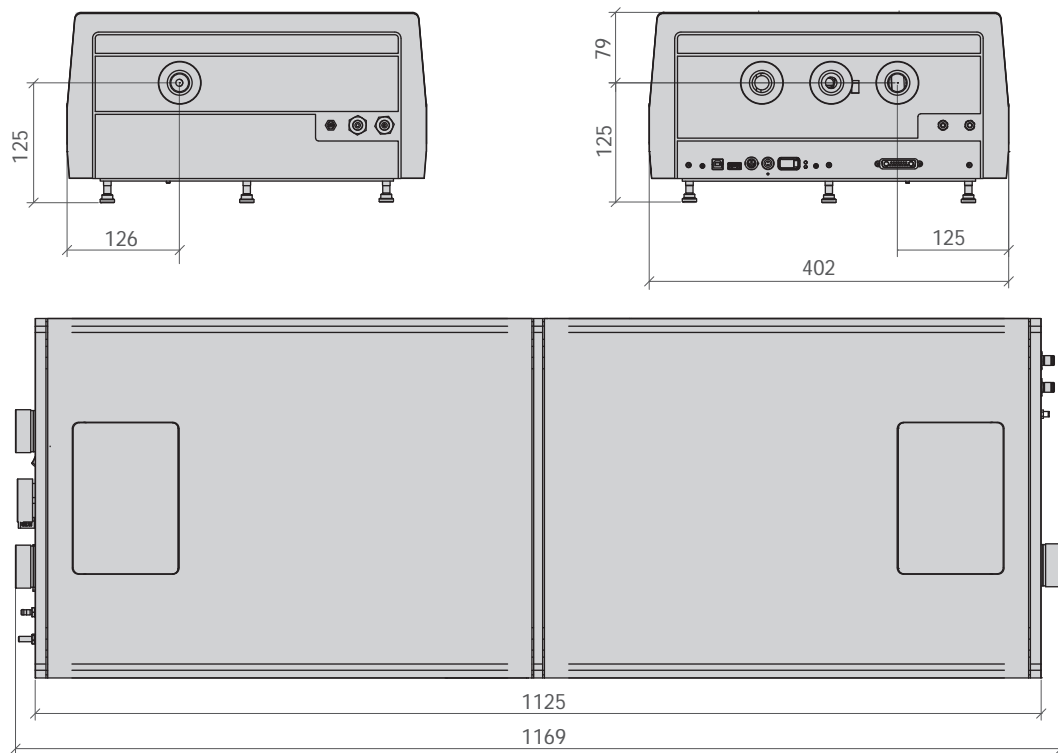

## HarmoniXX FHG

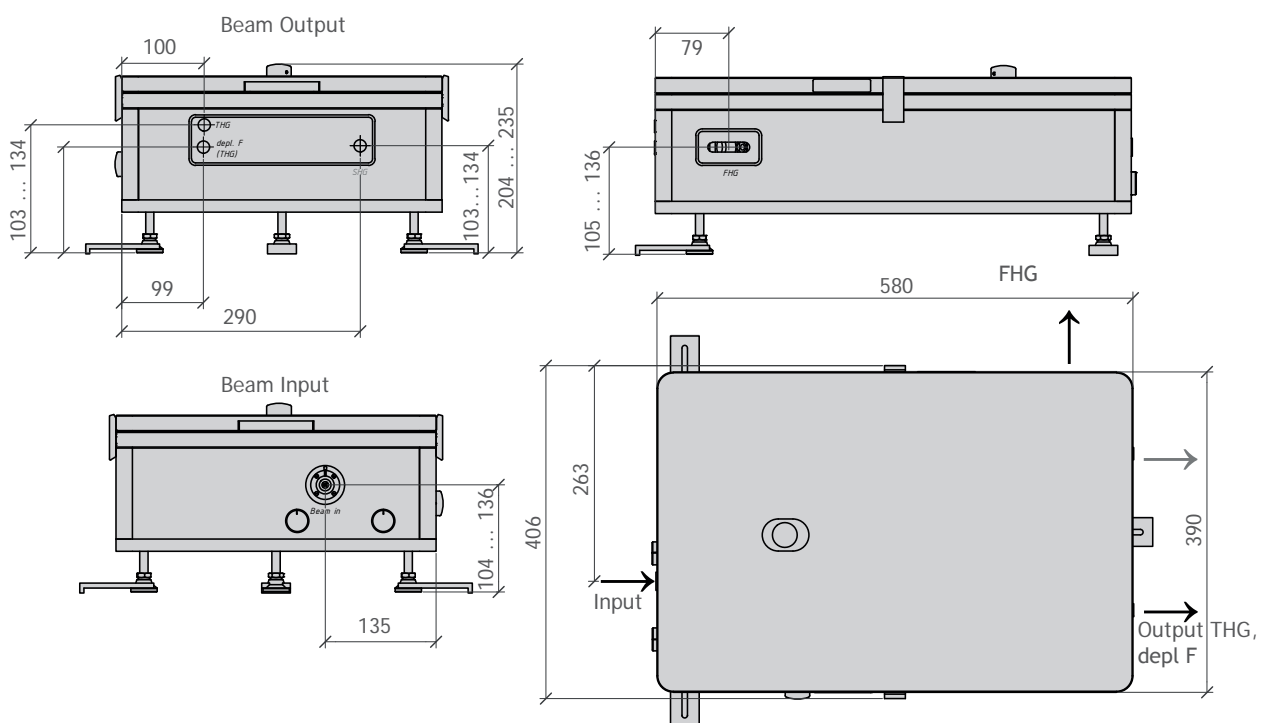

Contact

APE Angewandte Physik & Elektronik GmbH  
Plauener Str. 163-165 | Haus N | 13053 Berlin | Germany  
T: +49 30 986 011-30  
F: +49 30 986 011-333  
E: sales@ape-berlin.de  
www.ape-berlin.de

APE follows a policy of continued product improvement.  
Therefore, specifications are subject to change without notice.

© APE GmbH | Dec 2017 | Rev. 3.1.1.

Your local contact:

 [www.phototechnica.co.jp](http://www.phototechnica.co.jp)  
フォトテクニカ株式会社  
〒336-0017 埼玉県さいたま市南区南浦和 1-2-17  
TEL:048-871-0067 FAX:048-871-0068  
e-mail:voc@phototechnica.co.jp