

High Energy DPSS Picosecond Passively Q-Switched Laser

MPL300-YLF

FEATURES

- > Up to **50 mJ** pulse energy at **1053 nm**
- > Short pulse duration **< 500 ps**
- > Up to **100 Hz** repetition rate
- > High peak power **100 MW**
- > Air or water cooled
- > Excellent **TEM₀₀** and stable **SLM**
- > **527 nm, 351 nm, 263 nm**
- > Other wavelengths (1047 nm, 1064 nm, 1319 nm, 1338 nm, 1342 nm, 1079 nm, and its harmonic, etc.) available under request

APPLICATIONS

- > Cleaning
- > Material ablation and deposition
- > Medical
- > OLED repair
- > Pollution Monitoring
- > Remote sensing
- > Supercontinuum Generation
- > LIBS

MPL300-YLF series high pulse energy, DPSS passively Q-switched picosecond lasers are ideal choice for applications where high peak powers are needed. Diode pumped passively Q-switched single longitudinal mode (SLM) oscillator is the core of the system. Short picosecond optical pulse of 500 ps is directed to multi-pass diode pumped power amplifier for amplification to up to more than 50 mJ pulse energy. The power amplifier(s) are based on novel pump technology (VCSEL), which allows long-life system operation up to 20 G shots (compared with standard LD pumping – by order of magnitude longer). Thermocontrolled harmonic generators available as standard options. Each wavelength has a separate output port. Set of extremely high-performance parameters covers many applications like surface cleaning, material analysis (LIBS), pollution monitoring

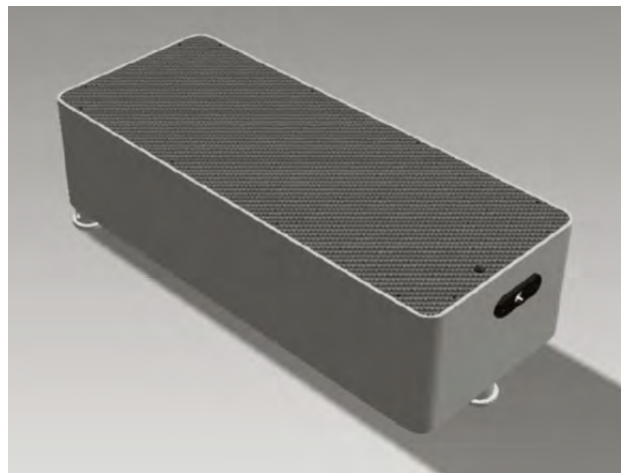

and many others. System is supplied with air or water cooling depends on repetition rate. Compact system footprint is welcome point for OEM integrators. Laser is controlled by supplied user-friendly software via PC USB port with application for Windows™ operating system.

Specifications ¹⁾

MODEL	MPL300-YLF	MPL330-YLF	MPL350-YLF
Pulse energy			
1053 nm	1 mJ	30 mJ	50 mJ
526.5 nm	0.5 mJ	15 mJ	25 mJ
351 nm	0.25 mJ	7 mJ	15 mJ
263 nm	0.1 mJ	3 mJ	7 mJ
Pulse energy stability (Std. Dev)			
1053 nm	< 1 % ²⁾		
526.5 nm	< 2 % ²⁾		
351 nm	< 3.5 % ²⁾		
263 nm	< 5% ²⁾		
Pulse duration (FWHM)			
< 500 ps ³⁾			
Power drift			
± 3 % ⁴⁾			
Pulse repetition rate			
10 Hz or other fixed in the range 0 – 100 Hz ⁵⁾			
Polarization			
vertical, > 99 % at 1064 nm			
Beam profile			
close to Gaussian in near and far fields			
Beam divergence			
	< 6 mrad ⁶⁾	< 1.5 mrad ⁶⁾	< 0.7 mrad ⁶⁾
Beam propagation ratio M²			
< 1.3			
Beam pointing stability			
≤ 20 μrad ⁷⁾			
Typical beam diameter			
	~ 1 mm ⁸⁾	~ 5 mm ⁸⁾	~ 7 mm ⁸⁾
Optical jitter			
~ 2 μs ⁹⁾			

DIMENSIONS

Laser head size (W × L × H)	113 × 163 × 46 mm	175 × 430 × 132 mm
Electrical cabinet size (W × L × H)	600 × 520 × 286 mm	440 × 420 × 286 mm
Umbilical length	2.5 m	

OPERATING REQUIREMENTS

Cooling	air or water
Ambient temperature	15 – 30 °C
Relative humidity	10 – 80 % (non-condensing)
Mains voltage	100 – 240 VAC, single phase. 50 – 60 Hz
Power consumption	max 100 W

- ¹⁾ Due to continuous improvements all specifications are subject to change. Unless stated otherwise all specifications are measured at 1053 nm.
- ²⁾ Averaged from pulses, emitted during 60 sec time interval.
- ³⁾ FWHM level at 1053 nm. Other pulse duration (from 300 ps to 20 ns) is available by request. Please inquire for detailed specifications.
- ⁴⁾ Over 8-hour period after max 5 minutes of warm-up when ambient temperature variation is less than ±2 °C.
- ⁵⁾ Factory-set pulse repetition rate is fixed at max repetition rate. Higher repetition rates are available, please inquire for details.
- ⁶⁾ Full angle measured at the 1/e² level.
- ⁷⁾ RMS value measured from 1000 shots.
- ⁸⁾ Beam diameter is measured 20 cm from laser output at the 1/e² level.
- ⁹⁾ In respect to Q-switch triggering rising edge pulse.

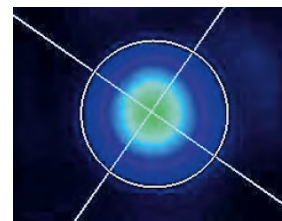

Typical beam profile of MPL300-YLF laser

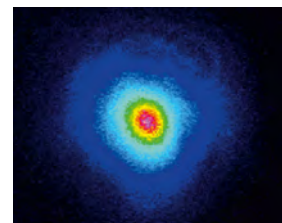

Typical beam profile of MPL330-YLF and MPL350-YLF lasers

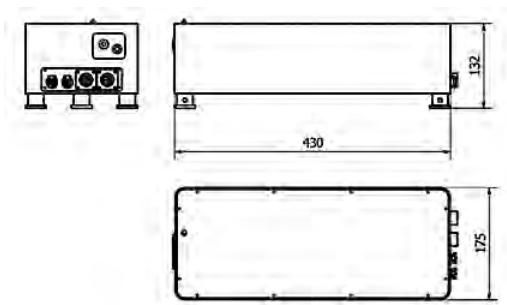

MPL330-YLF and MPL350-YLF laser model head dimensions (in mm)

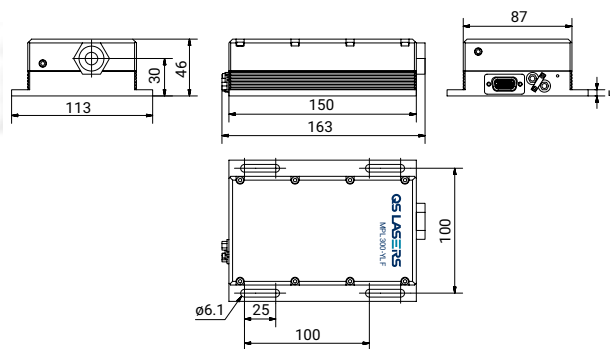

MPL300-YLF laser model head dimensions (in mm)