

NL230 SERIES



BENEFITS

- ▶ Short duration pulses (2 – 4 ns) ensures strong interaction with material and are highly suitable for LIBS
- ▶ User selectable wavelength single axis output is superior for experiments where alternating wavelengths are required such as material ablation and LIBS
- ▶ Rugged, monolithic design enables usage in harsh environments
- ▶ Diode pumped design provides quiet operation and eliminates flashlight irritation
- ▶ Variety of interfaces: USB, RS232, LAN and WiFi ensures easy control and integration with other equipment

The NL230 series diode-pumped Q-switched lasers produce up to 150 mJ at 100 Hz or up to 190 mJ at 50 Hz pulse repetition rate. Diode pumping allows maintenance-free laser operation for an extended period of time (more than 3 years for an estimated eight working hours per day). The typical pump diode lifetime is more than 1 billion shots.

Lasers are designed to produce high-intensity, high-brightness pulses and are targeted for applications such as LIBS, material ablation, remote sensing, OPO pumping. Due to an electro optical Q-switch, the master oscillator generates short duration pulses in the 2–4 ns range. The oscillator cavity optical design

features a variable reflectivity output coupler, giving a low-divergence laser beam.

A closed-loop air-cooled chiller is used for laser cooling, eliminating the need for external cooling water and reducing running costs.

Angle-tuned non-linear crystals mounted in temperature stabilized heaters are used for optional second or third harmonic generation. The harmonic separation system is designed to ensure radiation with a high spectral purity and to direct it to the separate output ports.

For customer convenience the laser can be controlled via a remote control pad or PC. The remote pad allows easy control of all parameters

High Energy Q-switched DPSS Nd:YAG Lasers

FEATURES

- ▶ Diode-pumped
- ▶ Rugged sealed laser cavity
- ▶ Up to **190 mJ** at **1064 nm** pulse energy
- ▶ Up to **100 Hz** pulse repetition rate
- ▶ Short pulse duration in the **2–4 ns** range
- ▶ Variable reflectivity output coupler for low-divergence beam
- ▶ Quiet operation: no more flashlamp firing sound
- ▶ Remote control via keypad and/or PC with supplied LabVIEW™ drivers
- ▶ Optional temperature-stabilized second and third harmonic generators

APPLICATIONS

- ▶ LIBS (Light Induced Breakdown Spectroscopy)
- ▶ Material ablation
- ▶ OPO pumping
- ▶ Remote Sensing
- ▶ LIDAR (Light Detection And Ranging)
- ▶ Mass Spectroscopy
- ▶ LIF (Light Induced Fluorescence)

and features a backlit display that is easy to read even through laser safety eyewear. Alternatively, the laser can be controlled from a personal computer via supplied Windows™ compatible software. LabVIEW™ drivers are also included with each laser installation package.

SPECIFICATIONS ¹⁾

Model	NL231-50	NL231-100
Pulse energy (not less than) ²⁾		
at 1064 nm	190 mJ	150 mJ
at 532 nm ³⁾	110 mJ	90 mJ
at 355 nm ⁴⁾	55 mJ	40 mJ
Pulse energy stability (StdDev) ⁵⁾		
at 1064 nm	< 1 %	
at 532 nm	< 2.5 %	
at 355 nm	< 3.5 %	
Pulse repetition rate	50 Hz	100 Hz
Power drift ⁶⁾	< ±1 %	
Pulse duration ⁷⁾	2 – 4 ns	
Linewidth	< 1 cm ⁻¹ at 1064 nm	
Beam profile ⁸⁾	"Top Hat" in near field and close to Gaussian in far field	
Beam divergence ⁹⁾	< 0.8 mrad	
Beam pointing stability (StDev) ¹⁰⁾	≤ 60 μrad	
Polarization	linear, > 95 % at 1064 nm	
Typical beam diameter ¹¹⁾	5 mm	
Optical pulse jitter (StDev)		
Internal triggering regime ¹²⁾	< 0.5 ns	
External triggering regime ¹³⁾	< 0.5 ns	
SYNC OUT pulse delay	-100 ms ... 100 ms	
Typical warm-up time	10 min	
PHYSICAL CHARACTERISTICS		
Laser head size (W × L × H)	251 × 291 × 167 ± 3 mm	
Power supply unit (W × L × H)		
Desktop case	471 × 391 × 147 mm ± 3 mm	
19" module	483 × 355 × 133 mm ± 3 mm	
External chiller	inquire	
Umbilical length	2.5 m	
OPERATING REQUIREMENTS		
Cooling (air cooled) ¹⁴⁾	external chiller	
Ambient temperature	18–27 °C	
Relative humidity (non-condensing)	20–80 %	
Power requirements	100–240 V AC, single phase, 50/60 Hz	
Power consumption	< 1.0 kVA	

¹⁾ Due to continuous improvement, all specifications are subject to change. The parameters marked typical may vary with each unit we manufacture. Unless stated otherwise all specifications are measured at 1064 nm and for basic system without options.

²⁾ Outputs are not simultaneous. Inquire for higher energy (up to 350 mJ at 50 Hz, 250 mJ at 100 Hz) custom models.

³⁾ With H230SHC or H230STHC harmonic generator module.

⁴⁾ With H230THC or H230STHC generator modules.

⁵⁾ Averaged from pulses, emitted during 30 sec time interval.

⁶⁾ Measured over 8 hours period after 20 min warm-up when ambient temperature variation is less than ± 2 °C.

⁷⁾ FWHM.

⁸⁾ Near field (at the output aperture) TOP HAT fit is >80%.

⁹⁾ Full angle measured at the 1/e² level.

¹⁰⁾ Beam pointing stability is evaluated as movement of the beam centroid in the focal plane of a focusing element.

¹¹⁾ Beam diameter is measured at 1064 nm at the 1/e² level.

¹²⁾ With respect to SYNC OUT pulse.

¹³⁾ With respect to QSW IN pulse.

¹⁴⁾ Adequate room air conditioning should be provided.

Notes: The laser and auxiliary units must be settled in such a place void of dust and aerosols. It is advisable to operate the laser in air conditioned room, provided that the laser is placed at a distance from air conditioning outlets. The laser should be positioned on a solid worktable. Access from one side should be ensured. Intensive sources of vibration should be avoided near the laboratory (ex. railway station or similar).



PERFORMANCE

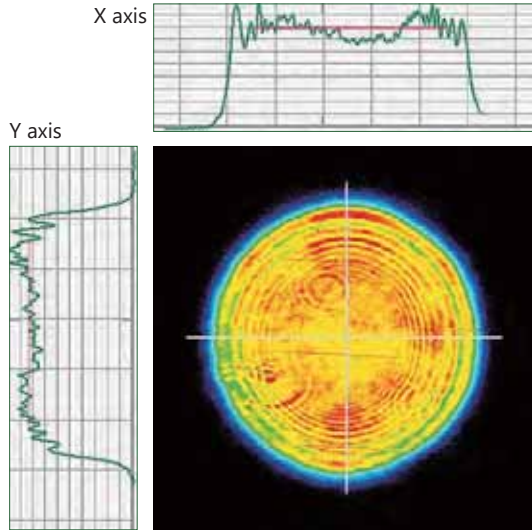

Fig 1. NL230 laser typical near field beam profile

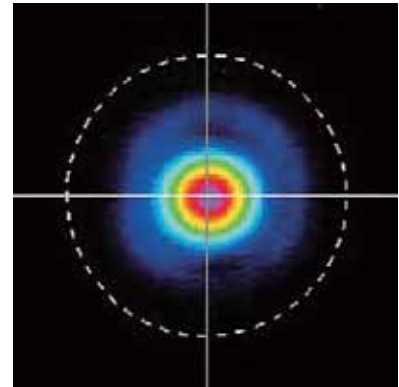

Fig 2. NL230 laser typical far field beam profile

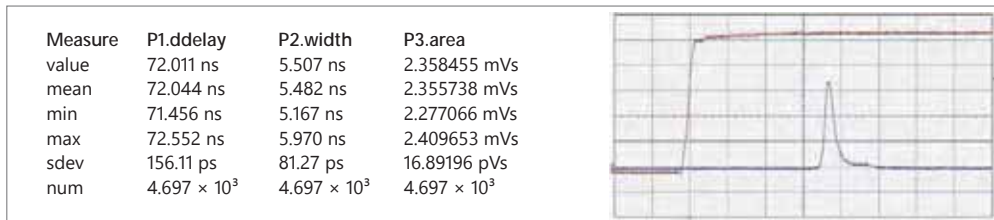

Fig 3. NL230 laser pulse waveform

OUTLINE DRAWINGS

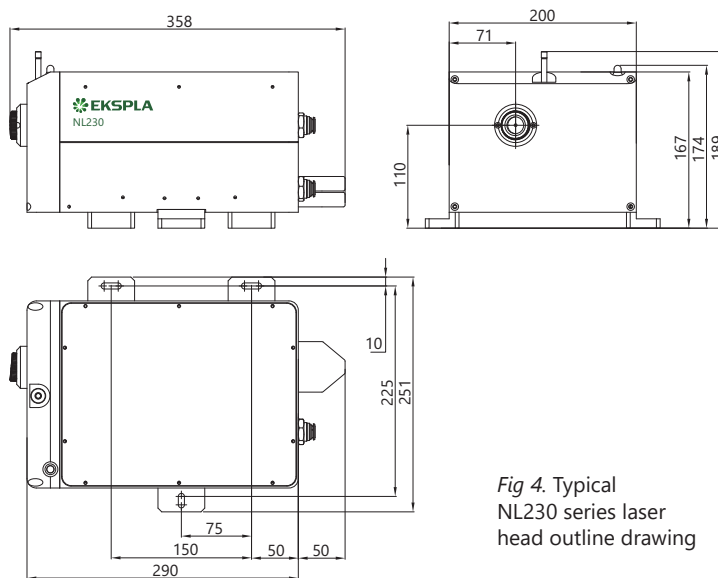
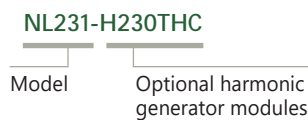

Fig 4. Typical NL230 series laser head outline drawing

ORDERING INFORMATION



Note: Laser must be connected to the mains electricity all the time. If there will be no mains electricity for longer than 1 hour then laser (system) needs warm up for a few hours before switching on.