

PT501 SERIES



PT501 series laser systems integrate a picosecond optical parametric oscillator (OPO) and a pump laser in a single compact housing. Mounting the components on the same frame provides a robust solution. It makes laser installation shorter, improves long-term stability, and reduces maintenance costs.

Fast and fully automatic wavelength tuning is achieved by advanced microprocessor control. The wavelength tuning elements are mounted on precise closed-loop micro-stepping motors. The temperatures of the nonlinear crystals are controlled by precise

thermo-controllers. No additional manual adjustment of the laser system is needed.

For customer convenience, the laser can be operated from a master device or a personal computer using various interfaces. Depending on the system configuration, control is available via the USB interface (REST API over RNDIS or VCP with ASCII commands), the RS-232 interface (ASCII commands), the LAN interface (REST API), or from the remote control pad with a backlit display that remains easy to read even while wearing laser safety glasses.

Single Housing Mid-Infrared Tunable Picosecond Laser System

FEATURES

- ▶ *Tuning range 2300 – 16000 nm (4345 – 625 cm⁻¹)*
- ▶ *Hands-free tuning: motorized for the entire tuning range*
- ▶ *Linewidth <3 cm⁻¹ in the entire tuning range*
- ▶ *Repetition rate 100 Hz*
- ▶ *Air cooled – external water supply is not required*
- ▶ *Beam direction stability in the entire tuning range*
- ▶ *Single housing: integrates a pump laser and OPO in a single housing*
- ▶ *PC control via USB (virtual COM port), RS232, LAN using REST API commands*
- ▶ *Fast wavelength scan (sweep)*

APPLICATIONS

- ▶ *Infrared spectroscopy*
- ▶ *SFG (sum frequency generation spectroscopy)*

PT501 series features

Model	Features
PT501	provides a narrowband radiation with a linewidth <3 cm ⁻¹ in the entire tuning range: 2300 – 16000 nm (4345 – 625 cm ⁻¹). Repetition rate 100 Hz.

SPECIFICATIONS ¹⁾

Model	PT501
Tuning range	2300–16000 nm
Output pulse energy	
at 3500 nm	> 200 µJ
at 10000 nm	> 50 µJ
Bandwidth	< 3 cm ⁻¹
Pulse repetition rate	100 Hz
Tuning resolution	< 0.5 cm ⁻¹
Typical beam size ²⁾	~4 mm
Beam divergence ³⁾	< 3 mrad
Beam pointing stability	≤ 100 µrad rms
Beam polarization	horizontal , > 100:1
Wavelength sweep	available
Optical pulse jitter	
Internal triggering regime ⁴⁾	< 50 ps (StdDev.) in respect to TRIG1 OUT pulse
External triggering regime ⁵⁾	~3 ns (StdDev.) in respect to SYNC IN pulse
TRIG1 OUT pulse delay	Positive pulse with controllable delay. Pulse width ~100 ns. Default delay – ~250 µs before optical pulse up to 10 ms.

PHYSICAL CHARACTERISTICS

Laser unit size (W × L × H)	~ 508 × 1030 × 244 mm
Power supply size (W × L × H)	450 × 450 × 140 mm

OPERATING REQUIREMENTS

Room temperature	22 ± 2 °C
Relative humidity	20–80 % (non-condensing)
Power requirements	100–240 V AC single phase, 47–63 Hz
Power consumption	< 0.5 kW
Cooling	air cooled
Cleanness of the room	not worse than ISO Class 9

¹⁾ Due to continuous improvement, all specifications are subject to change without notice. Parameters marked typical are not specifications. They are indications of typical performance and will vary with each unit we manufacture. Unless stated otherwise, all specifications are measured at 3500 nm for PT501 units for basic system without options.

²⁾ Beam diameter is measured at the 1/e² level.
³⁾ At 3000 nm, Full angle measured at the FWHM point
⁴⁾ With respect to TRIG1 OUT pulse. <10 ps jitter is provided with PRETRIG option.
⁵⁾ With respect to SYNC IN pulse.



Communication module interfaces

Interface	Description
USB*	REST API over RNDIS
RS232	ASCII commands
LAN	REST API

* Default, other option: ASCII commands over virtual serial port

TUNING CURVES

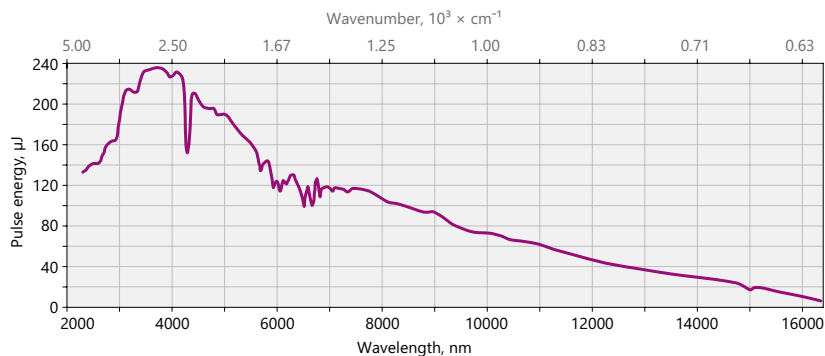

Fig 1. Typical PT501 tuning curve

OUTLINE DRAWINGS

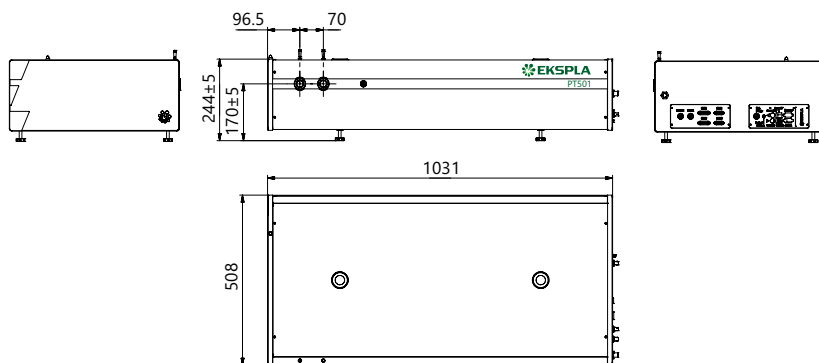

Fig 2. Typical PT501 outline drawing

**PHOTO
TECHNICA** www.phototechnica.co.jp
 フォトテクニカ株式会社
 〒336-0017 埼玉県さいたま市南区南浦和 2-18-2
 TEL:048-871-0067 FAX:048-871-0068
 e-mail:voc@phototechnica.co.jp