

CRONUS | 2P

Three-Channel Wavelength-Tunable Femtosecond Laser

FEATURES

- Three simultaneous and synchronized outputs
- Watt-level output, high repetition rate
- Automated GDD control
- Industrial-grade design
- High output stability



CRONUS-2P is a femtosecond laser providing watt-level three simultaneous and synchronized outputs with high repetition rate, short pulse duration, and GDD control, making it the ultimate source for nonlinear microscopy. Two outputs are independently tunable in the 680 – 960 nm and 960 – 1300 nm ranges, while the third is fixed at 1025 nm. The CRONUS-2P can be used for simultaneous excitation of multiple fluorescent probes, calcium indicators, or opsins at their absorption maxima, whereas second- and third-harmonic emission (SHG and THG) can be spectrally shifted for ease of detection or resonant enhancement.

The three simultaneous outputs also enable advanced coherent anti-Stokes and stimulated Raman scattering (CARS and SRS) applications with dual-band imaging, a broader selection of vibrational resonance frequencies, constant-difference dual-beam tuning, resonant enhancement, and more.

CRONUS-2P is a fully automated and robust next-generation laser system built on over 25 years of experience in designing and manufacturing femtosecond lasers and wavelength-tunable sources.

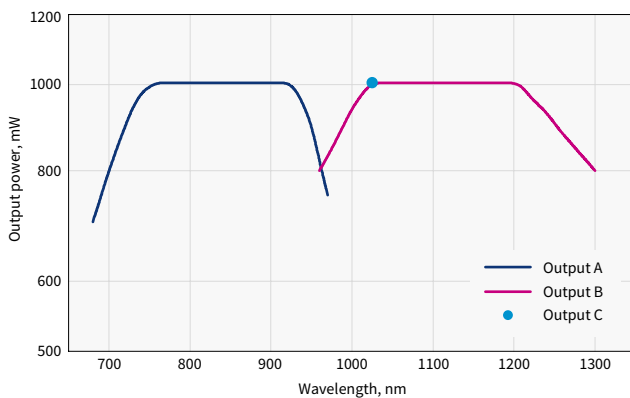

CRONUS-2P tuning curve

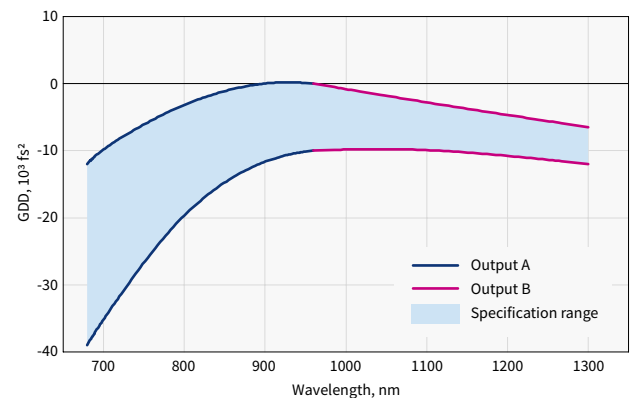

GDD control range

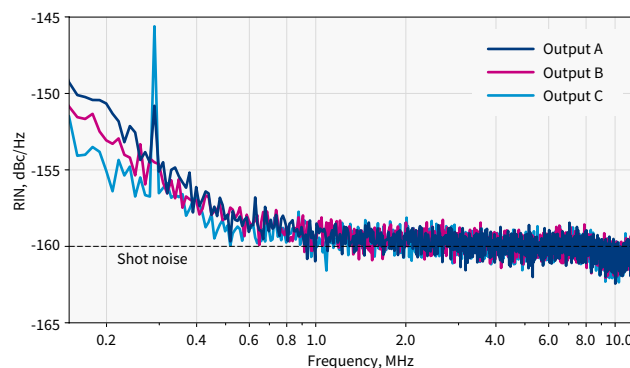

CRONUS-2P relative intensity noise (RIN)

SPECIFICATIONS

Model	CRONUS-2P		
	Output A	Output B	Output C
Tuning range	680 – 960 nm	960 – 1300 nm	1025 nm (fixed)
Output power	> 1 W @ 920 nm	> 1 W @ 1100 nm	> 1 W
Pulse duration ^{1) 2)}	< 160 fs		
Repetition rate	77 ± 1 MHz		
Beam quality ²⁾	TEM ₀₀ ; M ² < 1.2		
Polarization	Linear, horizontal		
Beam divergence, full angle	< 1 mrad		< 1.5 mrad
Beam diameter ²⁾ (1/e ²)	3.0 ± 0.4 mm	3.2 ± 0.4 mm	2.8 ± 0.4 mm
Beam ellipticity ²⁾	> 0.8		
Beam astigmatism ²⁾	< 20%		
Beam pointing stability ³⁾	< 200 μrad		-
Long-term power stability ^{2) 4)}	< 1%		
GDD control range	-10000 to -35000 fs ² @ 700 nm -3000 to -20 000 fs ² @ 800 nm 0 to -10 000 fs ² @ 960 nm	0 to -10 000 fs ² @ 960 nm -3000 to -10 000 fs ² @ 1100 nm -6 000 to -12 000 fs ² @ 1300 nm	-

ENVIRONMENTAL REQUIREMENTS

Altitude	< 2000 m
Temperature, operating	18 – 30 °C
Temperature, storage	10 – 35 °C
Relative humidity, operating	< 80% (non-condensing)

DIMENSIONS

Laser head (L × W × H)	806 × 528 × 311 mm
Rack for power supply and chiller (L × W × H)	642 × 553 × 673 mm

¹⁾ IR pulse duration determined assuming sech² shape.

²⁾ At 900 nm, 1100 nm, and 1025 nm, respectively.

³⁾ Beam pointing deviation over the entire tuning and GDD control range.

⁴⁾ Expressed as NRMSD (normalized root mean squared deviation) over 2 h with less than ±1 °C temperature change after 1 h warm up.

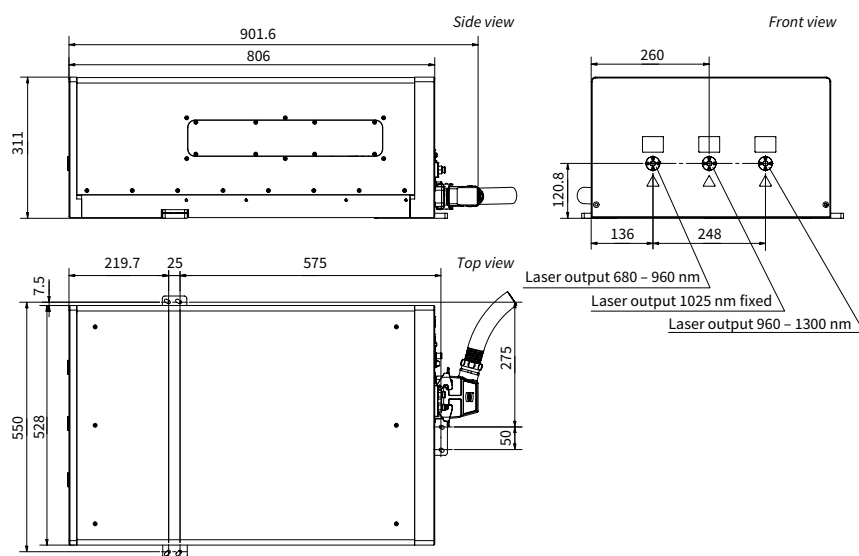
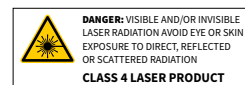

CRONUS-2P drawing