

**MODEL ASM SERIES  
UV ACOUSTO-OPTIC MODULATOR**

- INTENSITY MODULATION
- PHOTOLITHOGRAPHY
- OPTICAL FREQUENCY SHIFTING
- LASER BEAM DEFLECTION
- HIGH OPTICAL POWER CAPABILITY
- HIGH RELIABILITY
- EXCELLENT TEMPERATURE STABILITY

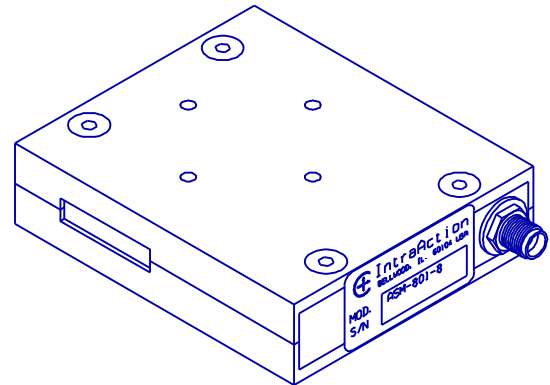

**SPECIFICATIONS**

Optical Wavelength Range	300 to 400 nm
Acousto-optic Material	UV Grade Fused Silica
Optical Insertion Loss	<4 percent
Optical Polarization	Linear vertical
Weight	175 grams
RF Connector	SMA
Size (less connector)	2.80 L x 2.40 W x 0.70 H inches 71.2 L x 61.0 W x 17.8 H mm
Input Impedance	50 ohms

**MODEL**

	<b>ASM-851B8</b>	<b>ASM-702B8</b>
Center Frequency <sup>1</sup>	85 MHz	70 MHz
Beam Separation <sup>2</sup> (360 nm)	5.14 mrad	4.24 mrad
Frequency Shift Range	" (70 to 100) MHz	" (55 to 85) MHz
Active Aperture Height	1 mm	2 mm
Diffraction Efficiency	80 percent	80 percent
RF Drive Power <sup>3,4</sup> (360 nm)	2 watts (360 nm)	2 watts (360 nm)
Modulation Bandwidth(-3db)	20 MHz (0.22mm dia.)	8.8 MHz (0.5mm dia.)
Optical Rise Time	24 nsec (0.22mm dia.)	55 nsec (0.5 mm dia.)

<sup>1</sup> Other frequencies available upon request

<sup>2</sup> Beam separation varies with optical wavelength

<sup>3</sup> RF drive power varies with optical wavelength

<sup>4</sup> Drive electronics available. ME-70/ME-85 (analog), ME-70T/ME-85T (digital) . OEM drivers also available.



**MODEL AOM-40AF SERIES  
ACOUSTO-OPTIC MODULATOR/FREQUENCY SHIFTER**

- INTENSITY MODULATION
- OPTICAL FREQUENCY SHIFTING
- LASER BEAM DEFLECTION
- HIGH OPTICAL POWER CAPABILITY
- HIGH RELIABILITY
- EXCELLENT TEMPERATURE STABILITY



**SPECIFICATIONS**

Acoustic Center Frequency <sup>1</sup>	40 MHz
Optical Frequency Shift Range	±(30 to 50) MHz
Acousto-optic Material	Dense Flint Glass
Acoustic Velocity	3630 m/sec
Modulation Bandwidth (-3db)	2.7 MHz (1.0 mm beam diameter) 1.8 MHz (1.5 mm beam diameter)
Optical Rise Time	177 nsec (1.0 mm beam diameter) 265 nsec (1.5 mm beam diameter)
Static Optical Insertion Loss	2 Percent (633nm)
Optical Polarization	Any
RF Input Impedance	50 Ohms (VSWR < 1.25:1 at CF)
RF Connector	BNC
Size (less connector)	0.88 H x 2.94 D x 2.46 W inches 22.4 H x 74.7 D x 62.5 W mm

<b>MODEL</b>	<b><u>AOM-402AF1</u></b>	<b><u>AOM-405AF1</u></b>	<b><u>AOM-402AF3</u></b>	<b><u>AOM-402AF4</u></b>
Optical Wavelength Range	440-700 nm	440-700 nm	700-1100 nm	1064 nm
Active Aperture Height <sup>2</sup>	2 mm	5 mm	2 mm	2 mm
Diffraction Efficiency	90 Percent	90 percent	90 Percent	85 Percent
Drive Power <sup>3</sup>	1.8 Watts (633 nm)	4.5 watts (633 nm)	3 Watts (780 nm)	5 Watts
Beam Separation	6.9 mrad (633 nm)	6.9 mrad (633 nm)	8.6 mrad (780 nm)	11.7 mrad

<sup>1</sup> Other center frequencies available.

<sup>2</sup> Other active aperture heights available.

<sup>3</sup> A complete line of analog, digital, dual frequency, OEM, and laboratory drive electronics are available.



**MODEL AOM-40AF SERIES  
ACOUSTO-OPTIC MODULATOR/FREQUENCY SHIFTER**

- INTENSITY MODULATION
- OPTICAL FREQUENCY SHIFTING
- LASER BEAM DEFLECTION
- HIGH OPTICAL POWER CAPABILITY
- HIGH RELIABILITY
- EXCELLENT TEMPERATURE STABILITY



**SPECIFICATIONS**

Acoustic Center Frequency <sup>1</sup>	40 MHz
Optical Frequency Shift Range	±(30 to 50) MHz
Acousto-optic Material	Dense Flint Glass
Acoustic Velocity	3630 m/sec
Modulation Bandwidth (-3db)	2.7 MHz (1.0 mm beam diameter) 1.8 MHz (1.5 mm beam diameter)
Optical Rise Time	177 nsec (1.0 mm beam diameter) 265 nsec (1.5 mm beam diameter)
Static Optical Insertion Loss	2 Percent (633nm)
Optical Polarization	Any
RF Input Impedance	50 Ohms (VSWR < 1.25:1 at CF)
RF Connector	BNC
Size (less connector)	0.88 H x 2.94 D x 2.46 W inches 22.4 H x 74.7 D x 62.5 W mm

<b>MODEL</b>	<b><u>AOM-402AF1</u></b>	<b><u>AOM-405AF1</u></b>	<b><u>AOM-402AF3</u></b>	<b><u>AOM-402AF4</u></b>
Optical Wavelength Range	440-700 nm	440-700 nm	700-1100 nm	1064 nm
Active Aperture Height <sup>2</sup>	2 mm	5 mm	2 mm	2 mm
Diffraction Efficiency	90 Percent	90 percent	90 Percent	85 Percent
Drive Power <sup>3</sup>	1.8 Watts (633 nm)	4.5 watts (633 nm)	3 Watts (780 nm)	5 Watts
Beam Separation	6.9 mrad (633 nm)	6.9 mrad (633 nm)	8.6 mrad (780 nm)	11.7 mrad

<sup>1</sup> Other center frequencies available.

<sup>2</sup> Other active aperture heights available.

<sup>3</sup> A complete line of analog, digital, dual frequency, OEM, and laboratory drive electronics are available.

**MODEL AOM-80    MODEL AOM-110**  
**ACOUSTO-OPTIC MODULATOR**

- HIGH OPTICAL POWER CAPABILITY
- INTENSITY MODULATION
- OPTICAL FREQUENCY SHIFTING
- HIGH RELIABILITY
- EXCELLENT TEMPERATURE STABILITY

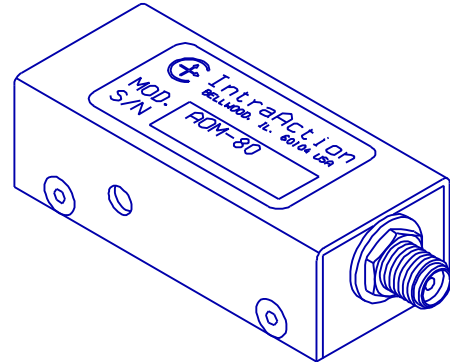

**SPECIFICATIONS**

Optical Wavelength Range	440 nm to 700 nm
Acousto-optic Material	Dense Flint Glass
Static Optical Insertion Loss	2 Percent (633nm)
Optical Polarization	Any
RF Input Impedance	50 Ohms
RF Connector	SMA
Size(less connector)	2.00 D x 0.63 H x 0.88 W inches 50.8 D x 16.1 H x 22.4 W mm

**MODEL AOM-80**

Acoustic Frequency	80 MHz
Active Aperture Height	1 mm

	<u>442 nm</u>	<u>633 nm</u>
Beam Separation	9.7 mrad	13.9 mrad
RF Drive Power	1 watt	2 watts
Static Optical Insertion Loss	7 percent	2 percent
Beam Diameter	0.18 mm / 0.36 mm	0.18 mm / 0.36 mm
Optical Rise Time	35 nsec / 70 nsec	35 nsec / 70 nsec
Modulation Bandwidth	15 MHz / 7.5 MHz	15 MHz / 7.5 MHz
Diffraction Efficiency	80 % / 85 %	70 % / 80 %

**MODEL AOM-110**

Acoustic Frequency	110 MHz
Active Aperture Height	0.6 mm

	<u>442 nm</u>	<u>633 nm</u>
Beam Separation	13.4 mrad	19.2 mrad
RF Drive Power	1 watt	2 watts
Static Optical Insertion Loss	5 percent	2 percent
Beam Diameter	0.14 mm / 0.28 mm	0.14 mm / 0.28 mm
Optical Rise Time	24 nsec / 48 nsec	24 nsec / 48 nsec
Modulation Bandwidth	20 MHz / 10 MHz	20 MHz / 10 MHz
Diffraction Efficiency	80 % / 80 %	70 % / 70 %

**MODEL ATM SERIES  
ACOUSTO-OPTIC MODULATOR**

- INTENSITY MODULATION
- FAST MODULATION CAPABILITY
- OPTICAL FREQUENCY SHIFTING
- BEAM DEFLECTION
- LOW DRIVE POWER
- HIGH RELIABILITY

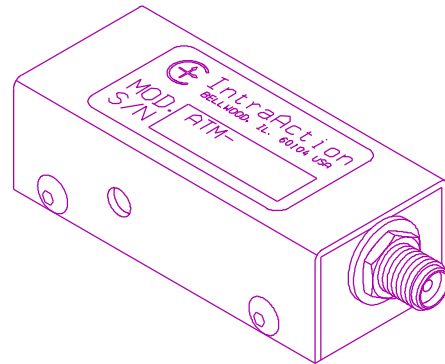

**SPECIFICATIONS**

Optical Wavelength Range <sup>1</sup>	440 nm to 700 nm
Acousto-optic Material	Tellurium Dioxide (TeO <sub>2</sub> )
Sound Velocity	4260 m/sec (longitudinal)
Input Impedance	50 ohms
Input VSWR	<1.3:1 at center frequency
Static Optical Insertion Loss	4 percent
Size (less SMA connector)	2.00 D X 0.63 H X 0.9 W inches 5.08 D X 1.60 H X 2.28 W cm

<b>MODEL</b>	<b><u>ATM-80A1</u></b>	<b><u>ATM-125B1</u></b>	<b><u>ATM-200C1</u></b>
Center Frequency	80 MHz	125 MHz	200 MHz
Active Aperture Height	1 mm	0.6 mm	0.3 mm
Beam Separation (633 nm)	11.9 mrad	18.6 mrad	29.7 mrad
Diffraction Efficiency	85 percent	80 percent	70 percent
RF Drive Power <sup>2</sup> (633 nm) (514 nm)	700 milliwatts 500 milliwatts	800 milliwatts 550 milliwatts	900 milliwatts 600 milliwatts
Optical Rise Time (beam diameter)	31 nsec (0.2 mm) 77 nsec (0.5 mm)	20 nsec (0.13 mm) 38 nsec (0.25 mm)	9.2 nsec (0.06 mm) 15.5 nsec (0.1 mm)
Modulation Frequency (-3 db)	15.8 MHz (0.2 mm) 6.3 MHz (0.5 mm)	24.5 MHz (0.13 mm) 12.8 MHz (0.25 mm)	50 MHz (0.06 mm) 30 MHz (0.1 mm)

<sup>1</sup> Specifications vary with optical wavelength.

<sup>2</sup> Drive electronics Model ME-801/ME-1251/ME-2001 analog input, ME-801T/ME-1251T/ME-2001T digital input. OEM drivers also available.

**MODEL ACM SERIES  
ACOUSTO-OPTIC MODULATOR / FREQUENCY SHIFTER**

- NEAR IR WAVELENGTH RANGE
- INTENSITY MODULATION
- OPTICAL FREQUENCY SHIFTING
- OPTICAL ISOLATION
- LOW RF DRIVE POWER
- HIGH RELIABILITY
- HIGH OPTICAL POWER CAPABILITY

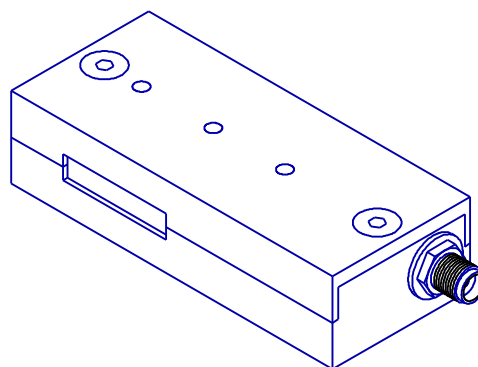

**SPECIFICATIONS**

Acousto-optic Material	AMTIR-1 Chalcogenide Glass
Optical Wavelength <sup>1</sup>	1.2 to 1.6 : $\mu$ m
Optical Power Capability	50 Kwatts / $\text{cm}^2$
Active Aperture Height <sup>2</sup>	2 mm
Diffraction Efficiency	90 percent
RF Drive Power <sup>3</sup>	600 milliwatts (1.55 : $\mu$ m)
RF Input Impedance	50 ohms
Modulation Bandwidth (-3db)	1.25 MHz (1.5 mm diameter)
Optical Rise Time	255 nsec / mm beam diameter
Static Optical Insertion Loss	5 percent (1.55 $\mu$ m)
Optical Polarization	any
RF Connector	SMA
Size (less connector)	2.80 L x 1.25 W x 0.70 H inches 71.2 L x 31.8 W x 17.8 H mm

<b>MODEL</b>	<b><u>ACM-402AA1</u></b>	<b><u>ACM-502AA1</u></b>	<b><u>ACM-802AA1</u></b>	<b><u>ACM-1002AA1</u></b>
Center Frequency <sup>4</sup>	40 MHz	50 MHz	80 MHz	100 MHz
Optical Frequency Shift	" 30 to 50 MHz	" 40 to 60 MHz	" 65 to 95 MHz	" 80 to 120 MHz
Beam Separation (1.55 $\mu$ m)	24.6 mrad	30.8 mrad	49.2 mrad	61.5 mrad

<sup>1</sup> Wavelengths available in the range of 1.2 to 2.5  $\mu$ m with appropriate antireflection coating. Specifications vary with optical wavelength.

<sup>2</sup> Other active aperture heights available with modified specifications.

<sup>3</sup> Fixed frequency, synthesized variable frequency, or OEM drivers are available.

<sup>4</sup> Any RF frequency from 40 to 250 MHz is available. Specifications vary with RF frequency.

**MODEL FCM SERIES  
FIBER PIGTAILED  
ACOUSTO-OPTIC MODULATOR/ATTENUATOR**

- NEAR IR WAVELENGTH RANGE
- INTENSITY MODULATION
- OPTICAL FREQUENCY SHIFTING
- CHOICE OF FREQUENCY SHIFT
- LOW RF DRIVE POWER
- HIGH RELIABILITY

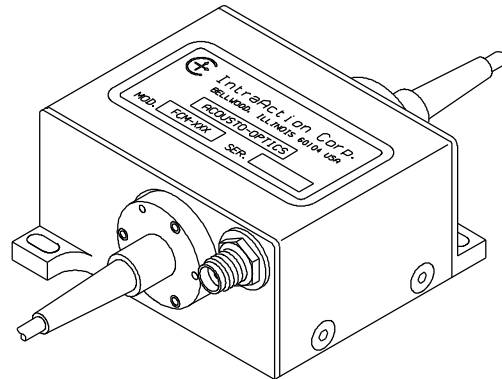

**SPECIFICATIONS**

Acousto-optic Material	AMTIR-1 Chalcogenide Glass
Optical Fiber <sup>1</sup>	Singlemode
Fiber Connector <sup>1</sup>	FC-PC
Optical Back Reflection <sup>2</sup>	-40 dB
Optical Polarization	any
Input Impedance / VSWR	50 Ohms / 1.2:1
Size	See outline drawing

<b>MODEL (Modulator)<sup>3</sup></b>	<b><u>FCM-40.8E5C</u></b>	<b><u>FCM-40.8E6C</u></b>	<b><u>FCM-401E5C</u></b>	<b><u>FCM-401E6C</u></b>
Optical Wavelength	1.55 $\mu$ m	1.3 $\mu$ m	1.55 : m	1.3 : m
RF Frequency <sup>4</sup>	40 MHz	40 MHz	40 MHz	40 MHz
Optical Frequency Shift	+ 40 MHz	+ 40 MHz	+ 40 MHz	+ 40 MHz
RF Drive Power <sup>5</sup>	600 mwatts	500 mwatts	500 mwatts	400 mwatts
Insertion Loss (RF on)	< 3 dB	< 3 dB	< 2.4 dB	< 2.4 dB
Extinction Ratio (RF on/RF off) <sup>5</sup>	> 55 dB	> 55 dB	> 55 dB	> 55 dB
Modulation Bandwidth (-3 dB)	7.5 MHz	7.5 MHz	4 MHz	4 MHz
Optical Rise Time	60 nsec	60 nsec	120 nsec	120 nsec

<b>MODEL (Attenuator)<sup>3</sup></b>	<b><u>FCM-40.8E5CA</u></b>	<b><u>FCM-40.8E6CA</u></b>	<b><u>FCM-401E5CA</u></b>	<b><u>FCM-401E6CA</u></b>
Optical Wavelength	1.55 $\mu$ m	1.3 $\mu$ m	1.55 : m	1.3 : m
RF Frequency <sup>4</sup>	40 MHz	40 MHz	40 MHz	40 MHz
RF Drive Power <sup>5</sup>	600 mwatts	500 mwatts	500 mwatts	400 mwatts
Insertion Loss (RF off)	< 1 dB	< 1 dB	< 1 dB	< 1 dB
Extinction Ratio (RF off/RF on)	7 dB	7dB	7dB	7 dB
Modulation Bandwidth (-3 dB)	7.5 MHz	7.5 MHz	4 MHz	4 MHz
Optical Rise Time	60 nsec	60 nsec	120 nsec	120 nsec

<sup>1</sup> Other optical fiber such as polarization maintaining, and other connectors such as FC-APC are also available.

<sup>2</sup> Optical back reflection varies with fiber type and connectors.

<sup>3</sup> Modulator...first order diffracted beam is transmitted to output fiber, Attenuator...zero order beam is transmitted to output fiber.

<sup>4</sup> Operation at other RF frequencies is available. See Frequency Shifter/FCM Series product sheet.

<sup>5</sup> High extinction digital drivers are available. Laboratory and OEM drivers are available.

**MODEL AGM-406B1**  
**IR ACOUSTO-OPTIC MODULATOR / FREQUENCY SHIFTER**

- INTENSITY MODULATION
- OPTICAL FREQUENCY SHIFTING
- OPTICAL ISOLATION
- LASER BEAM DEFLECTION
- HIGH RELIABILITY
- HIGH OPTICAL POWER CAPABILITY

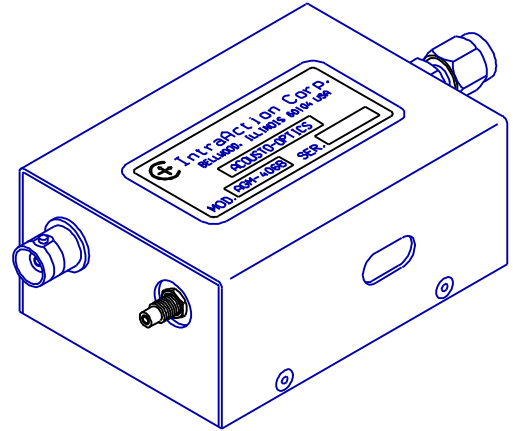

**SPECIFICATIONS**

Optical Wavelength <sup>1</sup>	10.6 $\mu$ m
Acousto-optic Material	Optical Single Crystal Germanium
Acoustic Velocity	5.5 mm/ $\mu$ sec
Center RF Frequency <sup>2</sup>	40 MHz
RF Bandwidth	20 MHz
Optical Frequency Shift Range	$\pm$ (30 MHz to 50 MHz)
Beam Separation	77 mrad (40 MHz)
Bragg Angle	38.5 mrad (40 MHz)
Diffraction Efficiency	85 percent
RF Drive Power <sup>3</sup>	30 watts
Active Aperture Height	6 mm
Modulation Bandwidth (-3db)	750 KHz (5.5 mm diameter)
Optical Rise Time	117 nsec / mm beam diameter
RF Input Impedance	50 ohms
Optical Insertion Loss	<12 percent
Optical Power Capability	100 watts full aperture
Optical Polarization	Parallel to mounting surface
Water Cooling	500 ml / min at 20 <sup>o</sup> C
Thermal Interlock Switch	NC opens at 45 <sup>o</sup> C
Size (less connectors)	2.97 D x 1.50 H x 2.42 W inches 75.4 D x 38.1 H x 61.5 W mm

<sup>1</sup> Other wavelengths and ranges from 2.5-11.5  $\mu$ m available. Note: Specifications change with optical wavelength.

<sup>2</sup> Other frequencies available.

<sup>3</sup> A complete line of drive electronics are available. Model GE-4030 analog input, GE-4030T digital input. OEM drivers are available.



**MODEL AGM-40 SERIES  
IR ACOUSTO-OPTIC MODULATOR/FREQUENCY SHIFTER**

- Intensity Modulation
- Optical Frequency Shifting
- Laser Beam Deflection
- High Reliability

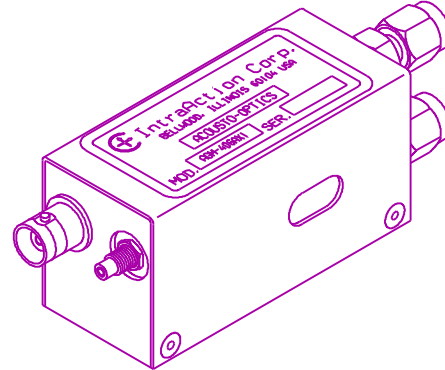

**SPECIFICATIONS**

Acousto-optic Material	Optical Single Crystal Geranium
Acoustic Velocity	5.5 mm / $\mu$ sec
RF Center Frequency <sup>1</sup>	40 MHz
Optical Frequency Shift Range	" (30 to 50) MHz
RF Input Impedance	50 ohms
Optical Insertion Loss	<7 percent
Optical Power Capability	25 watts full aperture
Laser Polarization	Parallel to Base
Water Cooling	250 ml / min, 20 degrees C
RF Connector	BNC
Size (less connectors)	2.95 L x 1.2 H x 1.3 W inches 7.50 L x 3.1 H x 3.3 W cm

<b>MODEL</b>	<b><u>AGM-402A1</u></b>	<b><u>AGM-406A1</u></b>	<b><u>AGM-402A3</u></b>	<b><u>AGM-406A3</u></b>
Optical Wavelength <sup>2</sup>	10.6 $\mu$ m	10.6 $\mu$ m	3.39 $\mu$ m	3.39 $\mu$ m
Active Aperture Height	2 mm	6 mm	2 mm	6 mm
Optical Rise Time (diameter)	116 nsec (1 mm)	582 nsec (5 mm)	116 nsec (1 mm)	582 nsec (5mm)
Modulation -3 dB Bandwidth	4.1 MHz (1 mm)	825 KHz (5 mm)	4.1 MHz (1 mm)	825 KHz (5 mm)
Beam Separation	77 mrad	77 mrad	24.7 mrad	24.7 mrad
Bragg Angle	38.5 mrad	38.5 mrad	12.3 mrad	12.3 mrad
Diffraction Efficiency	70 percent	50 percent	70 percent	70 percent
RF Drive Power <sup>3</sup>	20 watts	25 watts	2 watts	6 watts

<sup>1</sup> Other frequencies available

<sup>2</sup> Narrow and broadband A/R coatings in the range of 2.2  $\mu$ m to 12  $\mu$ m are available.

<sup>3</sup> Laboratory and OEM drive electronics available.

NOTE: Operating specifications change with optical wavelength.

## AOD-70 ACOUSTO-OPTIC DEFLECTOR ADM-70 ACOUSTO-OPTIC DEFLECTOR-MODULATOR

- Laser Beam Deflection
- Intensity Modulation
- Multiple Beam Generation
- Flat Optical Scan Response
- Acoustic Phased-array Design<sup>1</sup>
- Optical Signal Processing
- Optical Frequency Shifting
- High Reliability

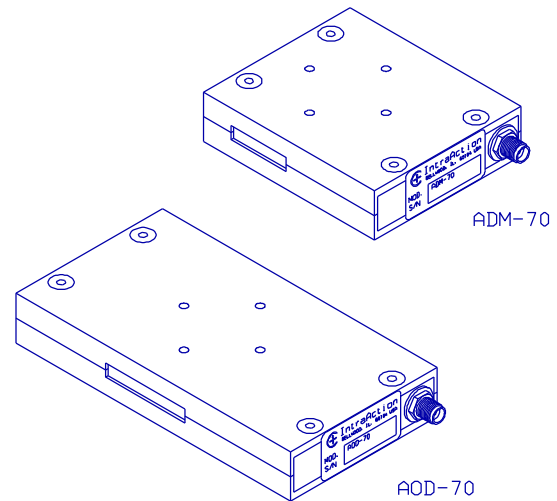
**SPECIFICATIONS**

Design Optical Wavelength <sup>2</sup>	633 nm
Acousto-optic Material	Dense Flint Glass
Diffraction Efficiency (center of scan)	80 percent
Diffraction Efficiency (edges of scan)	60 percent
Center Frequency	70 MHz
Deflection Bandwidth	40 MHz
Beam Separation	11.4 mrad (70 MHz)
Deflection Range	6.5 mrad
RF Drive Power <sup>3</sup> (nominal)	2.5 watts
Input Impedance (nominal)	50 ohms
Optical Polarization	any

**MODEL**

	<b><u>ADM-70</u></b>	<b><u>AOD-70</u></b>
Time-Bandwidth Product(resolution) <sup>4</sup>	200(spots)	400(spots)
Access Time (full aperture width)	5 : sec	10 : sec
Active Aperture Height	2 mm	2 mm
Active Aperture Width	20 mm	40 mm
Size (less connector)	2.8 L x 0.7 H x 2.4 W inches 7.1 L x 1.8 H x 6.1 W cm	4.5 L x 0.7 H x 2.4 W inches 11.5 L x 1.8 H x 6.1 W cm

<sup>1</sup> These deflectors incorporate an acoustic phased-array beam steering design to produce a relatively flat first order diffraction efficiency across the deflection bandwidth. Because of this design feature, the deflectors require a single RF power amplifier to drive the multiple transducer array.

<sup>2</sup> Useful at other wavelengths with modified specifications.

<sup>3</sup> A complete line of VCO, synthesized, laboratory, and OEM drive electronics are available.

<sup>4</sup> This is resolution as defined by the Rayleigh criterion for a uniformly illuminated optical beam.

**MODEL AGD-406B1  
INFRARED ACOUSTO-OPTIC DEFLECTOR**

- LASER BEAM DEFLECTION
- FLAT OPTICAL SCAN RESPONSE<sup>1</sup>
- OPTICAL FREQUENCY SHIFTING
- INTENSITY MODULATION
- HIGH OPTICAL POWER CAPABILITY
- EXCELLENT TEMP. STABILITY & RELIABILITY

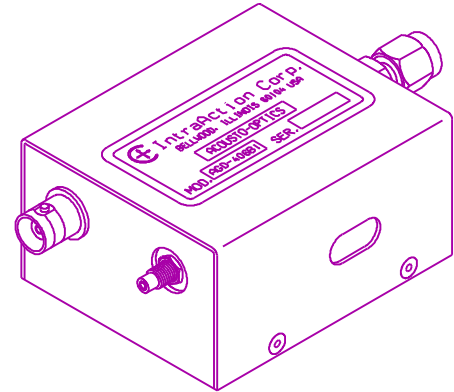

**SPECIFICATIONS**

Design Optical Wavelength <sup>2</sup>	10.6 $\mu$ m
Acousto-optic Material	Optical Single Crystal Germanium
Center RF Frequency	40 MHz
Deflection RF Bandwidth	20 MHz
Optical Frequency Shift Range	" (30 to 50) MHz
Beam Separation	77 mrad
Angular Deflection	38.5 mrad
Diffraction Efficiency	80 percent
RF Drive Power	30 watts (nominal)
Active Aperture Height	6 mm
Access Time	182 nsec / mm beam width
Time-Bandwidth Product	20 (5.5 mm beam width)
Intensity Modulation Bandwidth	750 KHz (5.5 mm beam diameter)
Optical Rise Time	117 nsec / mm optical beam width
Optical Polarization	Parallel to mounting surface
Static Optical Insertion Loss	<12 percent
RF Impedance	50 ohms (nominal)
RF Connector	BNC
Size (less connector)	2.97 D x 1.50 H x 2.42 W inches 75.4 D x 38.1 H x 61.5 W mm

<sup>1</sup> The Model AGD-406B1 incorporates an acoustic phased-array beam steering design which produces a relatively flat first order diffraction efficiency across the deflection bandwidth. Because of this design feature, the deflector requires a single RF power amplifier to drive the multiple transducer array.

<sup>2</sup> Deflectors can be designed to operate at other wavelengths in the range of 2.5 to 11  $\mu$ m.

<sup>3</sup> Two deflectors can be cascaded for various frequency shift ranges to produce an angular nonvariant frequency shifted optical beam.

<sup>4</sup> A complete line of VCO, synthesized, and OEM drive electronics are available.

**MODEL ATD-80 SERIES  
SLOW SHEAR MODE DEFLECTOR**

- LASER BEAM SCANNING
- OPTICAL SIGNAL PROCESSING
- RANDOM ACCESS DEFLECTION
- LOW DRIVE POWER
- RELIABLE

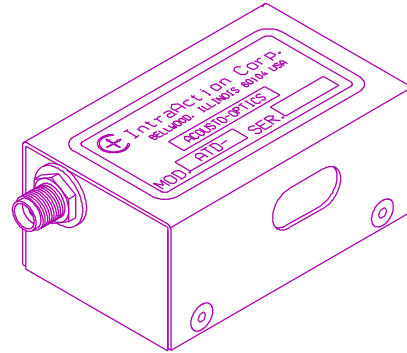

**SPECIFICATIONS**

Optical Wavelength Range	488 - 680 nm
Acousto-optic Material	Tellurium Dioxide (TeO <sub>2</sub> )
Operating Mode	Slow shear, off axis
Center Frequency	80 MHz
RF Bandwidth	50 MHz
Diffraction Efficiency	80% (minimum at center frequency)
Intensity Variation	<1 dB
Active Aperture <sup>1</sup>	5 H x 13 W mm
Input Optical Polarization	Linear, parallel to mount surface
Output Optical Polarization	Linear, perpendicular to mount surface
Static Optical Insertion Loss	5 percent
RF Drive Power <sup>2</sup>	1 Watt (514 nm)
Input Impedance	50 Ohms (nominal)
VSWR	<2.5:1
RF Connector	SMA
Size (less connector)	2.63 D X 1.00 H X 1.42 W inches 6.68 D X 5.08 H X 3.61 W cm

<b>MODEL</b>	<b><u>ATD-805AA1</u></b>	<b><u>ATD-805RA1</u></b>
Optical Wavelength	514 nm	633 nm
Beam Separation (80 MHz)	64.2 mrad	76.3 mrad
Deflection Angle	40.1 mrad	47.7 mrad
Acoustic Velocity	640 m / sec	663 m / sec
Access Time	1.56 : sec / mm beam width	1.51 : sec / mm beam width
Time-Bandwidth Product	78 / mm beam width	75 / mm beam width

<sup>1</sup> Other active aperture sizes are available.

<sup>2</sup> A complete line of frequency synthesized and VCO deflector drivers and RF power amplifiers are available.  
Note: The DTD Series of 2-axis deflectors are also available.



3719 Warren Avenue · Bellwood, IL 60104 · 708 547-6644 · Fax 708 547-0687 · iac@intraaction.com

**MODEL ATD / DTD COLLINEAR<sup>1</sup> SERIES  
1-AXIS / 2-AXIS ACOUSTO-OPTIC DEFLECTOR**

- LASER BEAM DEFLECTION
- COLLINEAR DESIGN<sup>1</sup>
- OPTICAL TWEEZERS
- LINEAR SCANNING
- LOW RF DRIVE POWER
- RELIABLE OPERATION

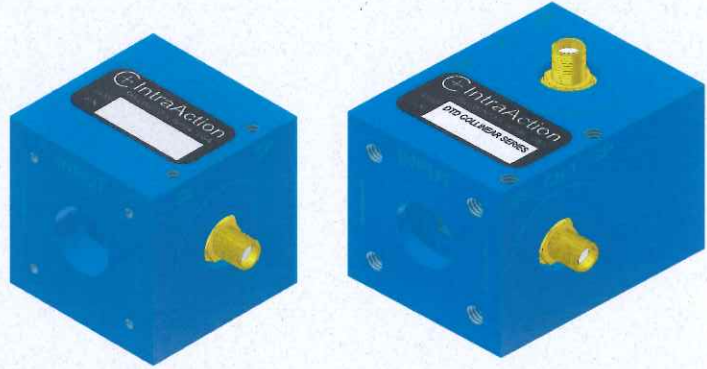

**SPECIFICATIONS**

Acousto-optic Material	Tellurium Dioxide (TeO <sub>2</sub> )
Operating Mode	Slow shear / off axis
Optical Insertion Loss	< 5 percent
First Order Diffraction Efficiency	>75 percent (per axis)
Optical Intensity Variation	<1 dB
Optical Input and Output Polarization <sup>2</sup>	Linear
Active Aperture Height <sup>3</sup>	4 mm
RF Drive Power <sup>4, 5</sup>	< 1 watt
Input Impedance	50 ohms (nominal)
RF Connectors	SMA
Size (less connectors), DTD(ATD)	1.50(1.50)D x 1.50(1.50)H x 2.0(1.50)W inches 38.1(38.1)D x 38.1(38.1)H x 50.8(38.1)W mm

<b>MODEL (ATD, 1-Axis; DTD, 2-Axis)</b>	<b><u>DTD-274HD6</u></b>	<b><u>DTD-604RC25</u></b>	<b><u>DTD-804RC17</u></b>
Optical Wavelength (λ)	1064 nm	780-785 nm	630-660 nm
Center RF Frequency (CF)	27 MHz	60 MHz	80 MHz
Deflection Bandwidth (BW at -1 dB)	18 MHz	36 MHz	50 MHz
Time-Bandwidth Product (4 mm)	110	215	300
Access time (per mm beam diameter)	1.6 μsec	1.5 μsec	1.5 μsec
Beam Separation <sup>6, 7</sup> (at CF)	45 mrad	71 mrad	76.6 mrad
Deflection Range <sup>6, 7</sup> (λ, BW)	30 mrad	42.4 mrad	47.5 mrad

<sup>1</sup> The nominal center of deflection area is collinear with the input optical beam. (Eliminates typical AO off-axis alignment)

<sup>2</sup> Input polarization is linear. 1-Axis output polarization is linear, rotated 90°; 2-Axis output polarization is linear, same as input.

<sup>3</sup> 5 or 6 mm Active Aperture Height is also available.

<sup>4</sup> For Optical Tweezers applications: Model DVE-120 synthesized, RF frequency, PCI computer card and DPA series power amplifier.

<sup>5</sup> For Linear Scanning applications: DE series Voltage Controlled Oscillator drivers.

<sup>6</sup> For 2-Axis: since both deflection angles can not originate at the same point, the origins are as close together as physically possible.

<sup>7</sup> For 2-axis operation, 2 relay lenses between 2 ATD can make the deflection origins of each axis the same.

## MODEL ME SERIES MODULATOR DRIVER

### DESCRIPTION

The Model ME series Modulator Drivers include a crystal controlled RF oscillator, fast modulation circuit, and a broadband RF power amplifier in a housing with power supply, RFI line filter, and line switch. The standard crystal controlled oscillator has a calibration tolerance of 25 ppm. Crystals at other than the specified frequencies can be factory installed. The standard modulation input configuration is analog with a digital input option available. A cw RF output level is adjusted by the front panel level control which inserts a dc offset to the input of the modulation circuit with no modulation input voltage. The class AB broadband amplifier has sufficient bandwidth for pulsed operation. RF output power capability can be up to 10 watts for some models. Configuration options include a front panel user accessible connection between the oscillator and modulation circuit (N) so that an external source frequency can be used in place of the internal crystal oscillator. Also available is an optional front panel connection between the modulation circuit and the RF power amplifier (H) to give the Model ME drivers capability to be used as a stand alone RF power amplifier. Drivers with option E provide a cw +10 dBm crystal oscillator reference output.

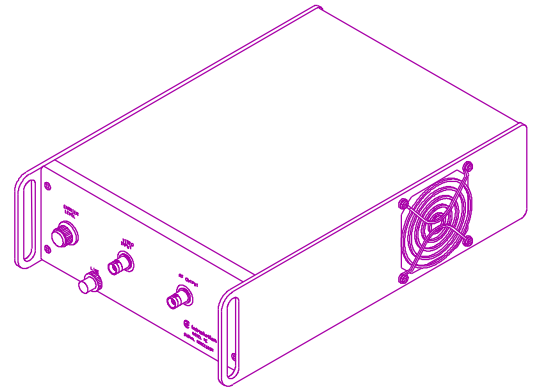

### SPECIFICATIONS

Input Configuration	Analog (0-1 volt for 0-specified RF power)
RF Amplifier Operation	Class AB
Rise/Fall Time	30 nsec
Harmonics (at full power)	-20 dBc
Output Mismatch Tolerance	100 percent
Input / Output Impedance	50 ohms
Extinction Ratio (RF on / RF off)	40 dB
Line Voltage (standard)	115/230 Vac, 50-60 Hz
	100 Vac, 50-60 Hz (option J)
Size (inches)	9.0 W x 3.5 H x 13.5 D
(cm)	22.9 W x 8.9 H x 34.3 D

MODEL	<u>ME-40</u>	<u>ME-405</u>	<u>ME-4010</u>	<u>ME-80</u>	<u>ME-110</u>	<u>ME-2001</u>
Oscillator Frequency <sup>1</sup>	40 MHz	40 MHz	40 MHz	80 MHz	110 MHz	200 MHz
RF Output Power <sup>2</sup>	2 watts	5 watts	10 watts	2 watts	2 watts	1 watt

OPTIONS: D...Inverse digital, input<0.8 volts for RF/on, input>2 volts to 5 volts for RF off, 50 S input impedance.  
 E...Low level oscillator RF output, +10 dBm level.  
 H...Front panel access between modulator circuit and RF power amplifier.  
 J...100 Vac line voltage for Japan.  
 N...Front panel access between oscillator and modulator circuit.  
 P...Internal pulse generator for q-switch applications with triggered, gated, and free running capability.  
 T...Digital input, input<0.8 volts for RF/off, input>2 volts to 5 volts for RF/on, 50 S input impedance.  
 T7...Same as option T, but with 70 dB extinction ratio.  
 -6...Analog input plus option T (analog + digital), total extinction ratio is 70 dB.

<sup>1</sup> Other frequencies available.

<sup>2</sup> Other RF output power levels available.

## MODEL GE SERIES HIGH POWER ACOUSTO-OPTIC MODULATOR DRIVER

### DESCRIPTION

The Model GE series high power acousto-optic modulator drivers include a crystal controlled RF oscillator, fast modulation circuit, and a broadband RF power amplifier in a housing with power supply, RFI line filter, line switch, and fault/interlock circuit. The standard crystal controlled oscillator has a calibration tolerance of 25 ppm. Crystals at other than the specified frequencies can be factory installed. The standard modulation input configuration is analog with a digital input option available. A CW RF output level is adjusted by the front panel level control which inserts a dc offset to the input of the modulation circuit with no modulation input voltage. The class AB broadband amplifier has sufficient bandwidth for pulsed operation. RF output power capability can be up to 100 watts for some models. Configuration options include a front panel user accessible connection between the oscillator and modulation circuit (H) so that an external source frequency can be used in place of the internal crystal oscillator.

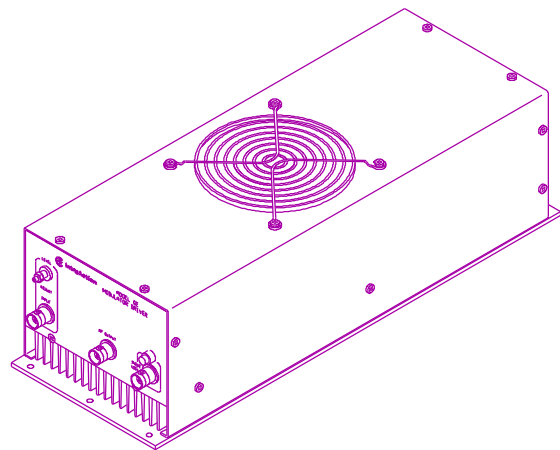

Also available is an optional front panel connection between the modulation circuit and the RF power amplifier (N) to give the Model GE drivers capability to be used as a stand alone RF power amplifier. The fault/interlock circuit will latch the power supply off when an open circuit condition is present and can be connected to the thermal switch of a Germanium infrared modulator or in a normally closed system interlock circuit.

### SPECIFICATIONS

Crystal Oscillator Stability	30 ppm
Input Configuration	Analog (0-1 volt for 0-maximum RF power)
RF Amplifier Operation	Class AB
Rise/Fall Time	30 nsec
Harmonics (at full power)	-20 dBc
Output Mismatch Tolerance	100 percent
Input / Output Impedance	50 ohms
Interlock Input Conditions	Shorted (power supply operational) Open (power supply latched off)
Line Voltage (standard)	115/230 Vac, 50-60 Hz (100 Vac, option J)
Size (inches)(cm)	5.7(14.5) W x 4.5(11.5) H x 16.0(40.7) D

MODEL	<b>GE-4030</b>	<b>GE-6030</b>	<b>GE-8030</b>	<b>GE-9020</b>	<b>GE-11020</b>
Oscillator Frequency <sup>1</sup>	40 MHz	60 MHz	80 MHz	90 MHz	110 MHz
RF Output Power <sup>2</sup>	30 watts	30 watts	30 watts	20 watts	20 watts

OPTIONS: D...Inverse digital, input<0.8 volts for RF/on, input>2 volts to 5 volts for RF off, 50 S input impedance.  
 E...Low level oscillator RF output, +10 dBm level.  
 H...Front panel access between oscillator and modulator circuit.  
 N...Front panel access between modulator circuit and RF power amplifier.  
 T...Digital input, input<0.8 volts for RF/off, input>2 volts to 5 volts for RF/on, 50 S input impedance.  
 T7...Same as option T (40 dB extinction ratio), but with 70 dB extinction ratio.  
 -6...Analog input plus option T (2 inputs), total extinction ratio is 70 dB.

<sup>1</sup>Other frequencies are available.      <sup>2</sup>Other RF power levels are available.

## MODEL DE SERIES DEFLECTOR DRIVER

### DESCRIPTION

The Model DE series Deflector Drivers include a voltage controlled RF oscillator and a broadband RF power amplifier in a housing with power supply, RFI line filter, and line switch. An optional (M) analog amplitude modulation circuit is available. Standard frequency linearity is " 0.25 percent. Standard frequency slew rate is 1 : sec for total frequency range. RF output power capability can be up to 10 watts for some models. Configuration options include a front panel user accessible connection between the voltage controlled oscillator and level/modulation circuit (H) so that an external source frequency can be used in place of the internal voltage controlled oscillator. Also available is an optional front panel connection between the level/modulation circuit and the RF power amplifier (N) to give the Model DE drivers capability to be used as a stand alone RF power amplifier. Drivers with option E provide a cw +10 dBm voltage controlled oscillator RF reference output.

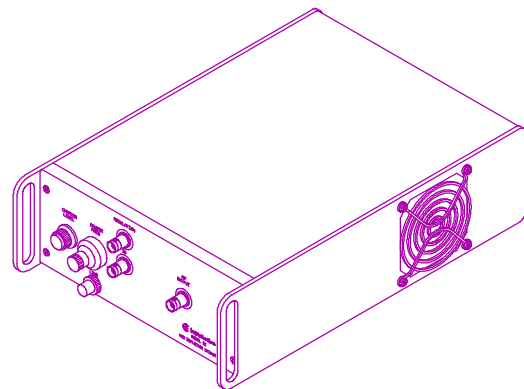

### SPECIFICATIONS

Frequency Control Voltage	Analog (1 volt peak-to-peak)
Frequency Slew Rate	1 : sec (total frequency range)
RF Amplifier Operation	Class AB
Rise/Fall Time (modulation option)	30 nsec
Harmonics (at full power)	-20 dBc
Output Mismatch Tolerance	100 percent
Input / Output Impedance	50 ohms
Line Voltage (standard)	115/230 Vac, 50-60 Hz 100 Vac, 50-60 Hz (option J)
Size (inches)	9.0 W x 3.5 H x 13.5 D
(cm)	22.9 W x 8.9 H x 34.3 D

MODEL	DE-40	DE-40S	DE-80	DE-1002	DE-1502
Center Frequency <sup>1</sup>	40 MHz	40 MHz	80 MHz	100 MHz	150 MHz
Frequency Range	20 MHz	20 MHz	40 MHz	50 MHz	100 MHz
RF Output Power Capability	2 watts	5 watts	2 watts	2 watts	2 watts

OPTIONS: D...Inverse digital, input<0.8 volts for RF/on, input>2 volts to 5 volts for RF off, 50 S input impedance.  
 E...Low level oscillator RF output, +10 dBm level.  
 H...Front panel access between oscillator and modulator circuit.  
 J...100 Vac line voltage for Japan.  
 M...Amplitude modulation (0-1 volt for 0 to specified RF output)  
 N...Front panel access between modulator circuit and RF power amplifier.  
 T...Digital input, input<0.8 volts for RF/off, input>2 volts to 5 volts for RF/on, 50 S input impedance.

<sup>1</sup> Other center frequencies and frequency ranges are available.



## MODEL DFE-A4 SERIES DUAL FREQUENCY SOURCE

### DESCRIPTION

The DFE Dual Frequency Source series are two-channel frequency generators capable of delivering up to four watts of RF power from each channel into a 50 ohm load. The DFE is used in applications where a very stable frequency difference is required. The fixed frequency and the variable frequency channels are both synthesized from the same temperature compensated crystal oscillator (TCXO). The variable frequency is set via front panel thumbwheel switches with a setting resolution of 10 kHz. Additional variable frequency control is available with optional parallel and serial port computer interfaces. Software is provided with the computer interface although instrument control software such as LabVIEW can be used. CW RF output is obtained by adjusting the front panel Carrier Level control. Amplitude modulation is electronically controlled with a 0 to 1 volt signal applied to the Video Input. A fixed +10 dBm RF reference output is also provided from each channel.

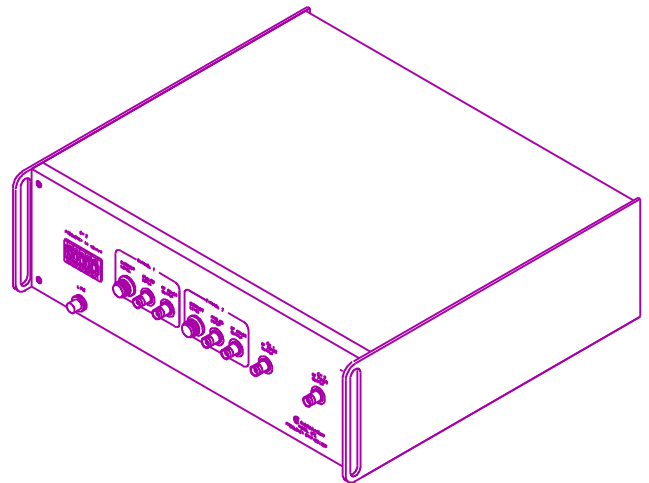

Amplitude modulation is electronically controlled with a 0 to 1 volt signal applied to the Video Input. A fixed +10 dBm RF reference output is also provided from each channel.

### SPECIFICATIONS

Variable Frequency Setting Resolution	10 kHz
Frequency Stability (0 to 50°C)	1 ppm (TCXO stability)
CW RF Output Power Capability	4 watts (0-4 watts for level control 0 - maximum)
Amplitude Modulation <sup>2</sup>	Analog (0-2 watts RF output for 0-1 volt input)
Harmonics at 4 Watts	- 20 dBc
Extinction Ratio (on/off)	40 dB
RF Reference Output	+10 dBm
Input / Output Impedance	50 ohms
RF Connectors	BNC
Line Power	115/230 Vac, 50-60 Hz
Size	5.5 H x 17.0 W x 13.5 D inches 14.0 H x 43.2 W x 34.3 D cm

MODEL	<u>DFE-404A4</u>	<u>DFE-604A4</u>	<u>DFE-804A4</u>	<u>DFE-1004A4</u>	<u>DFE-1504A4</u>
Fixed Frequency <sup>1</sup>	40 MHz	60 MHz	80 MHz	100 MHz	150 MHz
Variable Frequency	30-50 MHz	40-80 MHz	60-100 MHz	75-125 MHz	100-200 MHz

<sup>1</sup> The fixed frequency can be specified as any fixed frequency within the variable frequency range.

<sup>2</sup> Optional digital modulation capability is also available. Input impedance is 50 ohms.