

deltaEmerald

Dual Color SRS Imaging

Dual Color SRS Imaging

The new deltaEmerald allows simultaneous SRS imaging of two vibrational bands with its revolutionary dual color SRS (DC-SRS) scheme. It is aimed for users at the forefront of SRS microscopy, given the best signal-to-noise performance and the capability of background subtraction as well as simultaneous imaging of two vibrational bands. Two Stokes pulses, separated by 85 cm^{-1} and modulated at different frequencies are overlapped with the tunable Pump pulse.

The pulse length of about 1 ps, 10 cm^{-1} ... 15 cm^{-1} bandwidth and several 100 mW output power in each beam are ideal parameters for Coherent Raman imaging.

The pulses of all three beams are shot noise limited due to solid state laser design and proven OPO technology. The shot noise limited -162 dBc/Hz above 1 MHz (limited by the noise measurement setup with 4.8 mA) allows for fast image acquisition and superior signal-to-noise ratio.

Fully automated tuning, power control and temporal overlap of all three beams are given.

Additional a ~100 fs-output at 1030 nm is provided for efficient SHG and two-photon imaging.



- Innovative SRS scheme for simultaneous excitation of two vibrational band
- Tunable Pump and both Stokes pulses are spatially and temporally overlapped
- Spectral distance of Stokes 85 cm^{-1}
- Proven OPO technology with shot noise limited performance with -162 dBc/Hz above 1 MHz
- Additional femtosecond output at 1030 nm for optimum SHG and TPF excitation

deltaEmerald

Dual Color SRS Imaging

Applications

1. Simultaneous imaging of CH₂ & CH₃ for nondestructive and fast Coherent Raman histology. The 85 cm⁻¹ difference is chosen to address CH₂ & CH₃ with 2845 cm⁻¹ and 2930 cm⁻¹ at their peak position.
2. Background removal of non-resonant artefact's, especially important for weak signals in the fingerprint region.
3. Cosmetics / pharmaceutical imaging and further applications.

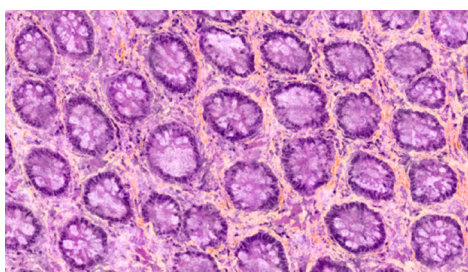

Colon, courtesy of LightCore Technology

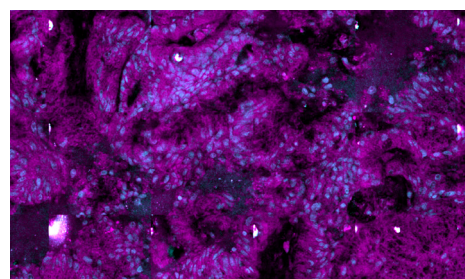

Biospie, courtesy of LightCore Technology

Specifications

Wavelength Stokes 1	1034 nm
Wavelength Stokes 2	1025 nm
Wavelength Pump (OPO Signal)	740 nm ... 990 nm
$\Delta\nu$ Pump - Stokes	350 cm ⁻¹ ... 3800 cm ⁻¹

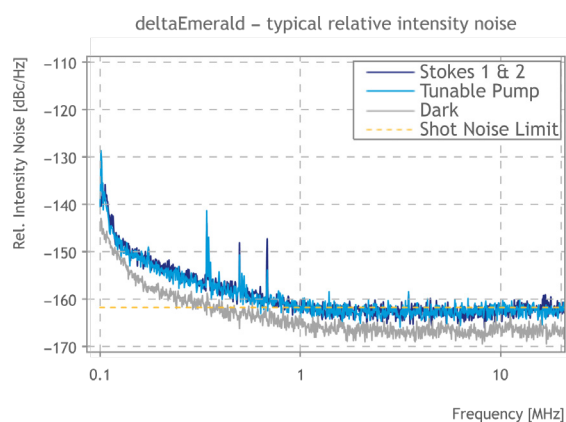
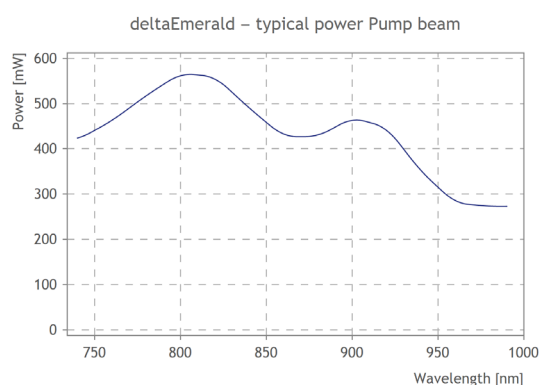

Specifications

Power Stokes 1	> 300mW (unmodulated), >150 mW modulated (20 MHz)
Power Stokes 2	> 300mW (unmodulated), >150 mW modulated (13 MHz)
Power Pump (OPO Signal)	> 400 mW at 800 nm

deltaEmerald

Specifications

Spectral bandwidth Pump and Stokes beams	10 cm ⁻¹ ... 15 cm ⁻¹
Pulse width	1 ps
Repetition rate	80 MHz
Noise	Shot noise limited (-162 dBc/Hz) > 1 MHz (Pump and Stokes)



Beam Parameters

Pointing stability	< 100 µrad per 100 nm
M ²	< 1.2 (Pump and Stokes)
Ellipticity	< 20%
Polarization	Linear; horizontal > 100:1
Beam divergence	0.9 (± 0.2) mrad (at 800 and Stokes)
Beam waist diameter	1.3 (± 0.2) mm at 800 nm; 1.7 (± 0.2) mm Stokes beams

Additional Femtosecond Output

Wavelength	1030 nm ± 3 nm
Power	300 mW
Pulse width	< 200 fs
Beam divergence	< 1.5 mrad

deltaEmerald

Features

Integrated modulators for Stokes beams	Built-in EOM with resonant fixed frequency of 20 MHz and 13 MHz
Power attenuators	Integrated for Pump and Stokes, independent for each beam
Delay management	Automated compensation for microscope dispersion
Remote control	Ethernet TCP/IP

Mechanical dimensions (L x W x H) / weight:

deltaEmerald	961 mm x 781 mm x 277 mm (see drawing for details) // 130 kg
Laser control unit	19 inch / 4U // 10 kg
Chiller	19 inch / 4U // 14 kg

Further requirements:

Power consumption	100 V ... 240 V, 50 Hz ... 60 Hz, max. 10 A (at 100 V)
Operating temperature	20°C ... 25°C, air conditioning (stability $\pm 1^\circ\text{C}$) recommended
Relative humidity	< 60%

dimensions in mm

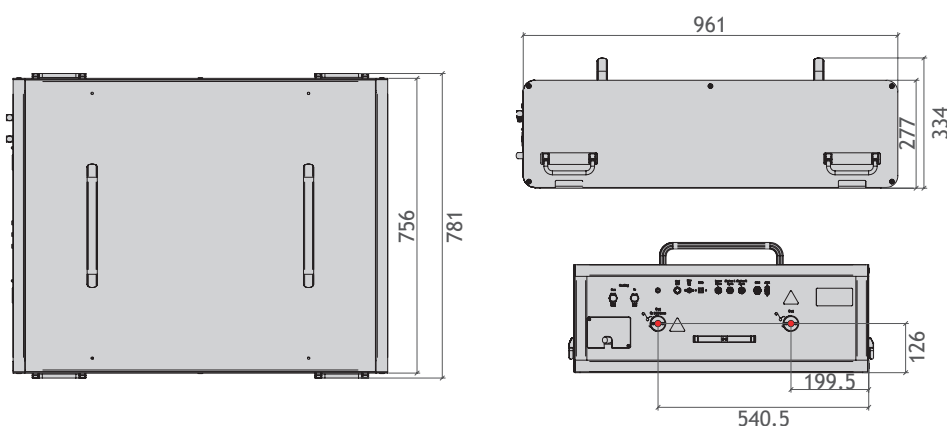

Contact

APE Angewandte Physik & Elektronik GmbH

Plauener Str. 163-165 | Haus N | 13053 Berlin | Germany

T: +49 30 986 011-30

F: +49 30 986 011-333

E: sales@ape-berlin.de

www.ape-berlin.de

Your local contact

www.phototechnica.co.jp
フォトテクニカ株式会社
 〒336-0017 埼玉県さいたま市南区南浦和 2-18-2
 TEL:048-871-0067 FAX:048-871-0068
 e-mail:voc@phototechnica.co.jp