

NEXOS™ SPECTROMETER



COMPACTLINE



Meet the NEXOS™ spectrometer, a compact device optimized for the best performance in system integration. This device is compatible with Avantes light sources, accessories, and AvaSoft software.

**POWERFUL.
VERSATILE.
COMPACT.**

NEXOS™ SPECTROMETERS

To be suitable for everyone, we offer three variations to match your application's needs.

1. NEXOS™ USB

Available with 2048 or 4096 pixel detector, and USB-powered with strengthened pigtail

2. NEXOS™ Link

Allows you to use a different communication protocol (RS232 or SPI) for smooth integration

3. NEXOS™ Bench Only

The Bench Only let's you combine our optical engine with your own electronics

WHY CHOOSE NEXOS™?

- Small size
- Improved optical bench design
- Smooth product or system integration
- Produced with AvaMation for unsurpassed inter-instrument reproducibility & scalability
- Superior stray light performance
- High signal-to-noise ratio
- USB-powered with pigtail
- Multiple variations available

APPLICATIONS & INDUSTRIES

The NEXOS™ spectrometers are suitable for a wide range of applications and industries, including;



Agriculture & Food
Food Sorting
Precision Agriculture

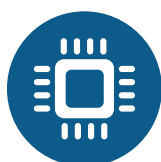

Semiconductor
Thin Film Coating
End-Point Detection



Environmental
Contamination &
Pollution Monitoring



(Bio)Medical
Blood Analysis
Cancer Detection



System Integration
Integrate into your
product or system

SPECIFICATIONS NEXOS™ SPECTROMETER

The information on this page relates to the USB-powered NEXOS™ spectrometer.

	NEXOS™ 2K	NEXOS™ 4K
Optical Bench	Symmetrical Czerny-Turner design, 75 mm focal length; NEXOS™ spectrometer bench	
Wavelength range	190 - 1100 nm	
Stray light	0.1 - 1% (typical value 300l/mm, blaze 300 nm < 0.3%)	
Detector	HAM S11639, CMOS linear array, 2048 pixels (14x200 μm)	HAM S13496, CMOS linear array, 4096 pixels (7x200μm)
Signal/Noise	375:1	365:1
Dynamic Range	4500	
Dark noise	15 cnts	
AD converter	16-bit, 6 MHz	
Integration time	9 μs – 30 s	
Interface	USB 2.0 (480Mbps) / pigtailed (38cm) USB-A	
Sample speed on-board averaging	0.36 ms/scan	0.70 ms/scan
Data transfer speed	0.79 ms/scan	1.12 ms/scan
Digital I/O	5 bidirectional programmable I/O; 1 Analog out, 1 Analog in, 1x5V	
Dimensions, weight	105 x 80 x 20 mm, 277,5 grams	
Power supply	Default USB power, 500 mA	
Temperature range	5-55 °C	

DIMENSIONS

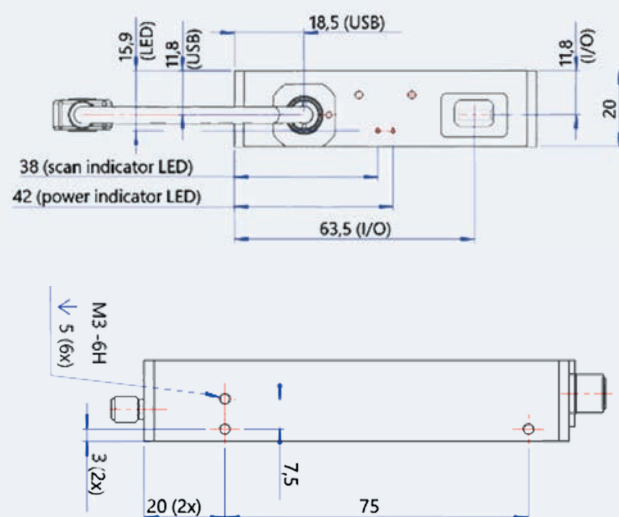
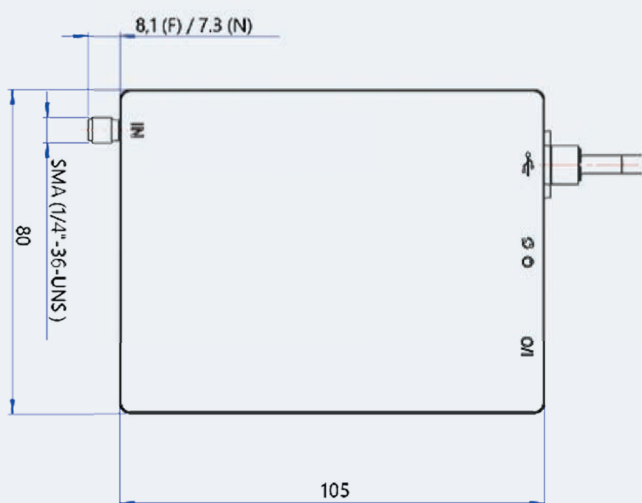

Dimensions in mm



FULL PRODUCT OVERVIEW & SPECIFICATIONS

Scan the QR-code for the full product overview, gratings, ordering options, and more. Discover the flexibility of the NEXOS™ spectrometer and find your ideal variation.

Discover all our empowering spectroscopy solutions on our website www.avantes.com

We reserve the right to make changes without prior notice. While every effort has been made to ensure all information in this document is accurate, Avantes accepts no liability for any inaccuracies.

NEXOS™ SPECTROMETER



TECHNICAL DATA

SPECIFICATIONS

	NEXOS™ 2K	NEXOS™ 4K
Optical Bench	Symmetrical Czerny-Turner design, 75 mm focal length; NEXOS™ Spectrometer bench	
Wavelength range	190 - 1100 nm	
Stray light	0.1 - 1% (typical value 300l/mm, blaze 300 nm < 0.3%)	
Detector	HAM S11639, CMOS linear array, 2048 pixels (14x200 μm)	HAM S13496, CMOS linear array, 4096 pixels (7x200μm)
Signal/Noise	375:1	365:1
Dynamic Range	4500	
Dark noise	15 cnts	
AD converter	16-bit, 6 MHz	
Integration time	9 μs – 30 s	
Interface	USB 2.0 (480Mbps) / pigtailed (38cm) USB-A	
Sample speed on-board averaging	0.36 ms/scan	0.70 ms/scan
Data transfer speed	0.79 ms/scan	1.12 ms/scan
Digital I/O	5 bidirectional programmable I/O; 1 Analog out, 1 Analog in, 1x5V	
Dimensions, weight	105 x 80 x 20 mm, 277,5 grams	
Power supply	Default USB power, 500 mA	
Temperature range	5-55 °C	

GRATINGS

Use	Useable range (nm)	Spectral range (nm)	Lines/mm	Blaze (nm)	Order code
UV/VIS/NIR	190-1160**	910**	300	300	MN0300-0.30
UV/VIS	190-850	544-540*	600	300	MN0600-0.30
UV	190-750	261-256*	1200	250	MN1200-0.25
UV	190-650	168-152*	1800	UV	MN1800-0.25
UV	190-580	121-103*	2400	UV	MN2400-0.25
UV	190-400	72-57*	3600	UV	MN3600-0.25
UV/VIS	250-850	536-532*	600	400	MN0600-0.40
VIS/NIR	300-1160**	800**	300	500	MN0300-0.50
VIS	360-1000	529-519*	600	500	MN0600-0.50
VIS	300-800	247-216*	1200	500	MN1200-0.50
VIS	350-750	147-121*	1800	500	MN1800-0.50
VIS	350-640	96-89*	2400	VIS	MN2400-0.50
NIR	500-1050	515-506*	600	750	MN0600-0.75
NIR	500-1050	210-204*	1200	750	MN1200-0.75
NIR	600-1160	339-300*	830	800	MN0830-0.80
NIR	600-1160**	500**	300	1000	MN0300-1.00
NIR	600-1160	500	600	1000	MN0600-1.00

Note: a selection of starting wavelength is possible, contact us for available configurations.

* Depends on the starting wavelength of the grating; the higher the wavelength, the bigger the dispersion and smaller the range to select

** Please note that not all pixels will be used for the useable range

MORE DATA ON THE NEXT PAGE >

RESOLUTION NEXOS™ 2K

Slit size (μm)	10	25	50	100	200	500
300 lines/mm grating	1.0	1.4	2.25	4.8	9.2	21.3
600 lines/mm grating	0.40-0.53*	0.7	1.2	2.4	4.6	10.8
830 lines/mm grating	0.32	0.48	0.93	1.7	3.4	8.5
1200 lines/mm grating	0.20-0.28*	0.27-0.38*	0.52-0.66*	1.1	2.3	5.4
1800 lines/mm grating	0.10-0.18*	0.20-0.29*	0.34-0.42*	0.8	1.6	3.6
2400 lines/mm grating	0.09-0.13*	0.13-0.17*	0.26-0.34*	0.44-0.64*	1.1	2.7
3600 lines/mm grating	0.06-0.08*	0.10	0.19	0.4	0.8	1.8

*Depends on the starting wavelength of the grating; the higher the wavelength, the bigger the dispersion and the higher the resolution.

RESOLUTION NEXOS™ 4K

Slit size (μm)	10	25	50	100	200	500
300 lines/mm grating	0.50-0.70	1.4	2.25	4.8	9.2	21.3
600 lines/mm grating	0.30-0.36*	0.7	1.2	2.4	4.6	10.8
830 lines/mm grating	0.25	0.48	0.93	1.7	3.4	8.5
1200 lines/mm grating	0.14-0.18*	0.27-0.38*	0.52-0.66*	1.1	2.3	5.4
1800 lines/mm grating	0.09-0.11*	0.20-0.29*	0.34-0.42*	0.8	1.6	3.6
2400 lines/mm grating	0.07-0.09*	0.13-0.17*	0.26-0.34*	0.44-0.64*	1.1	2.7
3600 lines/mm grating	0.05-0.06*	0.10	0.19	0.4	0.8	1.8

*Depends on the starting wavelength of the grating; the higher the wavelength, the bigger the dispersion and the higher the resolution.

ORDERING INFORMATION

Order code	Ordering information
AvaSpec-NXS2048CL	NEXOS™ fiber-optic spectrometer, 75 mm focal length, 2048 pixel CMOS detector, USB 2 powered interface, needs DCL, second order suppressing, replaceable slit
AvaSpec-NXS4096CL	NEXOS™ fiber-optic spectrometer, 75 mm focal length, 4096 pixel CMOS detector, USB 2 powered interface, needs DCL, second order suppressing, replaceable slit
*OEM AvaSpec-NXS2048CL	OEM NEXOS™ fiber-optic spectrometer, 75 mm focal length, 2048 pixel CMOS detector, USB 2 powered interface, needs DCL, second order suppressing, fixed slit
*OEM AvaSpec-NXS4096CL	OEM NEXOS™ fiber-optic spectrometer, 75 mm focal length, 4096 pixel CMOS detector, USB 2 powered interface, needs DCL, second order suppressing, fixed slit

* Only for OEM customers

CONFIGURATION DEPENDANT PARAMETERS

Order code	Parameter information
SLIT-XX-PRS	Replaceable Slit for NEXOS™ spectrometer for non OSF configurations. Slit size, please specify XX = 10, 25, 50, 100, 200, 500 μm
SLIT-XX-PRSF	Replaceable Slit for NEXOS™ spectrometer for OSF configurations. Slit size, please specify XX = 10, 25, 50, 100, 200, 500 μm
*SLIT-XX-P	Fixed Slit for NEXOS™ spectrometer. Slit size, please specify XX = 10, 25, 50, 100, 200, 500 μm
OSC	Order sorting coating for grating MN 0600-0.50
OSC-UA	Order sorting coating for grating MN 0300-0.30 / MN 0300-0.50
OSC-UB	Order sorting coating for grating MN 0600-0.50
OSF-YYY-3	Order sorting filter for reduction of second-order effects, possible: YYY = 305, 395, 457, 515, 550, or 600 nm, depending on range
DCL	Detector Collection Lens. To be included

* Only for OEM customers

Avantes will select needed second order suppression based on desired configuration.

Discover all our empowering spectroscopy solutions on our website www.avantes.com

We reserve the right to make changes without prior notice. While every effort has been made to ensure all information in this document is accurate, Avantes accepts no liability for any inaccuracies.