

VARIUS™ OEM NIR ENHANCED SPECTROMETER



STARLINE



Discover the VARIUS™ OEM NIR Enhanced Spectrometer. The standard VARIUS™ OEM has been reimagined with an advanced detector to deliver unparalleled performance in near-infrared spectroscopy.

Designed for professionals who demand precision, reliability, and enhanced sensitivity, this latest development positions the VARIUS™ OEM as the ultimate solution for your needs.

ADVANTAGES DETECTOR

The Near-Infrared enhanced detector has the following advantages:

- Enhanced sensitivity in 700 - 1100 nm range
Up to 2x increase.
- Enhanced NIR quantum efficiency
- Faster data transfer time compared to backthinned models
- Smooth spectrum
- Temperature stability

WHY CHOOSE VARIUS™ OEM

- Patented optical bench design
- EMC shielded housing
- Semi-automated production for unsurpassed inter-instrument reproducibility & scalability
- Superior stray light performance
- High signal-to-noise ratio
- Easy to operate with intuitive software
- Cost-effective instrument
- Easy integration into products or solutions

APPLICATIONS & INDUSTRIES

The NIR Enhanced VARIUS™ OEM Spectrometer is suitable for applications such as;



Food Sorting



Raman



VCSEL/Laser



System Integration

SPECIFICATIONS VARIUS™ OEM NIR ENHANCED SPECTROMETER

	VARIUS™ 2K	VARIUS™ 4K
Optical Bench	Symmetrical Czerny-Turner design, 75 mm focal length; VRS bench	
Wavelength range	400 - 1160 nm	
Stray light	0.1 - 1% (typical value 300 l/mm, blaze 300 nm < 0.3%)	
Detector	NIR Enhanced CMOS linear array, 2048 pixels (14x200 µm)	NIR Enhanced CMOS linear array, 4096 pixels (7x200 µm)
Signal/Noise	375:1	365:1
Dynamic Range	4500	
Dark noise	15 cnts	
AD converter	16-bit, 6 MHz	
Integration time	9 µs – 30 s	
Interface	USB 3.0 high speed (5Gbps), Gigabit Ethernet (1 Gbps)	
Sample speed on-board averaging	0.38 ms/scan	0.70 ms/scan
Data transfer speed	0.38 ms/scan (USB3.0), 1.0 ms (ETH)	0.70 ms/scan (USB3.0), 1.31 ms (ETH)
Digital I/O	HD-26 connector, 2 Analog in, 2 Analog out, 13 Digital bidirectional, trigger, sync., strobe, laser	
Dimensions, weight	179x110,1x44,8 mm - 799,5 grams	
Power supply	Default USB3 power, 500 mA or 12 VDC, 300 mA	
Temperature range	5-55 °C	

DIMENSIONS IN MM

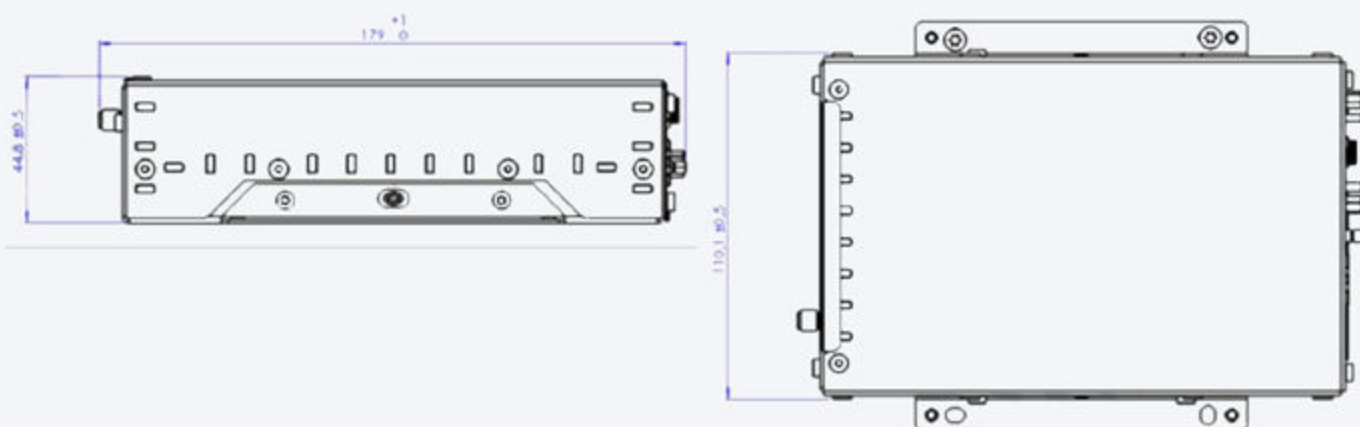

GRATINGS

Use	Useable range (nm)	Spectral range (nm)	Lines/mm	Blaze (nm)	Order code
UV/VIS	250-850	536-532*	600	400	MN0600-0.40
VIS/NIR	300-1160**	800**	300	500	MN0300-0.50
VIS	360-1000	529-519*	600	500	MN0600-0.50
VIS	300-800	247-216*	1200	500	MN1200-0.50
VIS	350-750	147-121*	1800	500	MN1800-0.50
VIS	350-640	96-89*	2400	VIS	MN2400-0.50
NIR	500-1050	515-506*	600	750	MN0600-0.75
NIR	500-1050	210-204*	1200	750	MN1200-0.75
NIR	600-1160	339-300*	830	800	MN0830-0.80
NIR	600-1160**	500**	300	1000	MN0300-1.00
NIR	600-1160	500	600	1000	MN0600-1.00

Note: a selection of starting wavelength is possible, contact us for available configurations.

* Depends on the starting wavelength of the grating; the higher the wavelength, the bigger the dispersion and smaller the range to select

** Please note that not all pixels will be used for the useable range

RESOLUTION VARIUS™ 2K (FWHM in nm)

Slit size (μm)	10	25	50	100	200	500
300 lines/mm grating	1.0	1.4	2.25	4.8	9.2	21.3
600 lines/mm grating	0.40-0.53*	0.7	1.2	2.4	4.6	10.8
830 lines/mm grating	0.32	0.48	0.93	1.7	3.4	8.5
1200 lines/mm grating	0.20-0.28*	0.27-0.38*	0.52-0.66*	1.1	2.3	5.4
1800 lines/mm grating	0.10-0.18*	0.20-0.29*	0.34-0.42*	0.8	1.6	3.6
2400 lines/mm grating	0.09-0.13*	0.13-0.17*	0.26-0.34*	0.44-0.64*	1.1	2.7

*Depends on the starting wavelength of the grating; the higher the wavelength, the bigger the dispersion and the higher the resolution.

RESOLUTION VARIUS™ 4K - (FWHM in nm)

Slit size (μm)	10	25	50	100	200	500
300 lines/mm grating	0.50-0.70	1.4	2.25	4.8	9.2	21.3
600 lines/mm grating	0.30-0.36*	0.7	1.2	2.4	4.6	10.8
830 lines/mm grating	0.25	0.48	0.93	1.7	3.4	8.5
1200 lines/mm grating	0.14-0.18*	0.27-0.38*	0.52-0.66*	1.1	2.3	5.4
1800 lines/mm grating	0.09-0.11*	0.20-0.29*	0.34-0.42*	0.8	1.6	3.6
2400 lines/mm grating	0.07-0.09*	0.13-0.17*	0.26-0.34*	0.44-0.64*	1.1	2.7

*Depends on the starting wavelength of the grating; the higher the wavelength, the bigger the dispersion and the higher the resolution.

ORDERING INFORMATION

Order code	Ordering information
AvaSpec-VRS-OEM	VARIUS™ OEM NIR Enhanced fiber-optic spectrometer, 75 mm AvaBench for OEM Customers. Contact one of our offices for ordering information regarding the VARIUS™ OEM

CONFIGURATION DEPENDANT PARAMETERS

Order code	Parameter information
SLIT-XX-PRS	Replaceable Slit for VARIUS™ spectrometer for non OSF configurations. Slit size, please specify XX = 10, 25, 50, 100, 200, 500 μm
SLIT-XX-PRSF	Replaceable Slit for VARIUS™ spectrometer for OSF configurations. Slit size, please specify XX = 10, 25, 50, 100, 200, 500 μm
OSC	Order sorting coating for grating MN 0600-0.50 and MN 0600-0.40 (>350 nm)
OSC-UA	Order sorting coating for grating MN 0300-0.50
OSC-UB	Order sorting coating for grating MN 0600-0.40 (<350 nm)
OSF-YYY-3	Order sorting filter for reduction of second-order effects, possible: YYY = 395, 475, 515, 550, or 600 nm, depending on range
DCL	Detector Collection Lens. To be included

Avantes will select the optimal second order suppression based on desired configuration.



www.phototechnica.co.jp

フォトテクニカ株式会社

〒336-0017 埼玉県さいたま市南区南浦和 2-18-2

TEL:048-871-0067 FAX:048-871-0068

e-mail:voc@phototechnica.co.jp

Discover all our empowering spectroscopy solutions on our website www.avantes.com

We reserve the right to make changes without prior notice. While every effort has been made to ensure all information in this document is accurate, Avantes accepts no liability for any inaccuracies.

