

High Speed Liquid Crystal Variable Retarder System

Meadowlark's newest liquid crystal (LC) product, the high speed LC variable retarder (HS LCVR) has a 10X speed improvement over our award winning standard LCVR. The sub-millisecond speeds are achieved without the 50/50 duty cycle drive scheme required by our ferroelectric liquid crystal components, but are nearly as fast. The new HS LCVR uses nematic liquid crystal materials to electrically control polarization and provide tunable retardation by changing the effective birefringence of the material with applied voltage, thus altering the input polarized light to any chosen elliptical, linear or circular polarization.

Our precision HS LCVR requires unique fabrication and assembly steps. We construct these retarders using optically flat fused silica windows coated with our transparent conductive Indium Tin Oxide (ITO). Our ITO coating is specially designed for maximum transmission over the operating wavelength.

Response Time

Meadowlark's HS LCVR utilizes unique surface alignment procedures coupled with precise temperature control and a new drive scheme to achieve the fastest possible switching times. The HS LCVR reaches switching speeds of ~ 50 microseconds to switch from one-half to zero waves (low to high voltage) and ~ 500 microseconds to switch from zero to one-half wave (high to low voltage) at 532 nm.



Key Features

• • •

- Sub-millisecond speeds
- Standard LC Drive Schemes
- Includes heated housing
- Precision non-mechanical retardation control

Liquid Crystal Suite

• • •

- Variable Retarders**
 - Liquid Crystal Variable Retarder
 - UV Variable Retarder
 - MWIR Variable Retarder
 - OEM LCVR
- Rotators**
 - Achromatic High Speed Rotator
 - Binary Rotator
 - Polarization Rotator
- Shutters / Attenuators**
 - Achromatic High Speed Shutter
 - High Contrast Shutter
 - Variable Attenuator

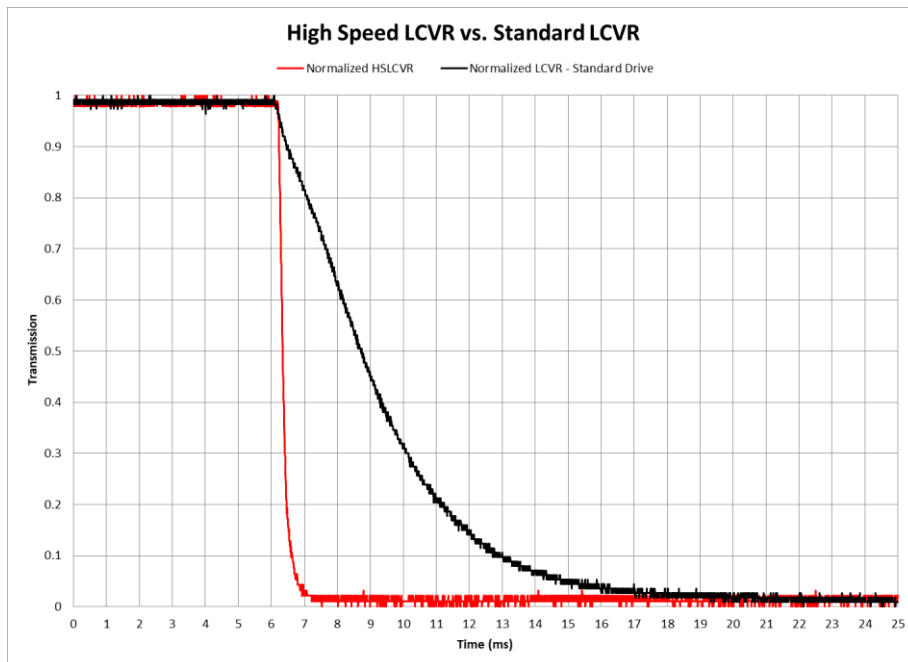



Meadowlark Optic's HS LCVR must be paired with a D5020-HS digital interface. The D5020-HS will keep the HS LCVR at optimum temperature and voltage ranges for best performance. The driver features 4 separate drive schemes and has the ability to drive two HS LCVR cells at the same time.

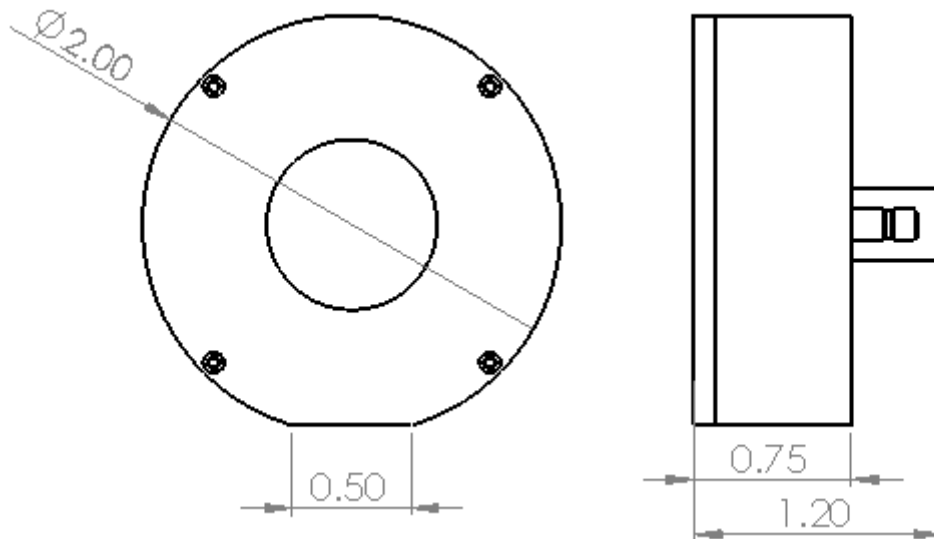

SPECIFICATIONS

Retarder Material	Nematic liquid crystal
Substrate Material	Optical quality synthetic fused silica
Wavelength Range	450 – 700 nm
Typical LC Rise Time (10 – 90%) Typical LC Fall Time (90 – 10%)	50 μ s @ 532 nm 500 μ s @ 532 nm
Retardance	0 to $\lambda/2$
Transmitted Wavefront Distortion (at 632.8 nm)	$\leq \lambda/4$
Surface Quality	40 – 20 scratch-dig
Beam Deviation	≤ 2 arc min
Reflectance (per surface)	$\leq 0.5\%$ at normal incidence
Operating Temperature (Internally Heated)	50°C
Recommended Safe Operating Limit	500 W/cm ² , CW 300 mJ/cm ² , 10 ns, visible

ORDERING INFORMATION

Diameter, D (in.)	Clear Aperture, CA (in.)	Thickness, T (in.)	Part Number
2.00	0.70	0.75	HLC – 200 – VIS

DRIVER SPECIFICATIONS

Fundamental Drive Waveform	10 kHz AC square wave
Modulation Amplitude	0 – 20 V rms
DC Offset	<5 mV
Communication Interface	USB
Output Channels	2 Cells
Modulation Waveforms	Chop, Gate, Steady State, Idle
CE Compliance	Compliant

meadowlark optics

**PHOTO
TECHNICA**

www.phototechnica.co.jp

フォトテクニカ株式会社

〒336-0017 埼玉県さいたま市南区南浦和 1-2-17

TEL: 048-871-0067 FAX: 048-871-0068

e-mail: voc@phototechnica.co.jp