

## Glan-Thompson Polarizer

Calcite is a naturally occurring birefringent crystal. By precisely controlling internal prism angles in these calcite polarizers, a very efficient linear polarizer is produced.

Meadowlark Optics offers Glan-Thompson Polarizers, intended for precision optical instrumentation and low power laser applications. Key advantages of Glan-Thompson Polarizers include excellent extinction ratio performance and a broad spectral range.

Our Glan-Thompson Polarizers are supplied in a black anodized cylindrical housing for easy mounting. The housing is marked to indicate the polarization axis of the transmitted beam. The rejected component of the beam is totally internally reflected and eventually absorbed by the anodized aluminum.

Although raw calcite material transmits down to 215 nm, the cement interface limits ultraviolet transmission. For this reason, we recommend Glan-Thompson Polarizers for use over 320 – 2300 nm.

Three antireflection coating options cover the visible to near infrared range. Uncoated Glan-Thompson Polarizers are also available.

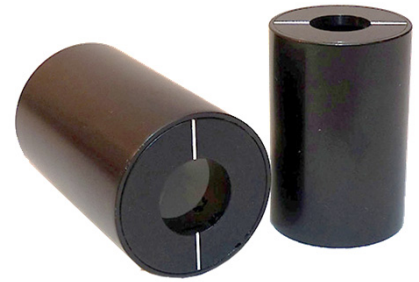

### Key Features

• • •

- Broad spectral range
- Excellent extinction ratio
- Wide field of view
- Low wavefront distortion

### Polarization Suite

• • •

#### Linear Polarizers

- Precision Linear Polarizer
- High Contrast Linear Polarizer
- Ultra-High Contrast Linear Polarizer
- Glan-Thompson Polarizer
- Ultra Broadband Polarizer
- MWIR Polarizer
- Deep Ultraviolet Polarizer

#### Beamsplitting Polarizers

- Wire Grid Versalight Polarizer
- Wire Grid Versalight Beam Splitter
- Laser Line Beamsplitting Polarizer
- Broadband Beamsplitting Polarizer
- Polarizing Bandpass Filter

#### Circular Polarizers

- Dichroic Circular Polarizer
- Beam Separator

Glan - Thompson Polarizer Construction

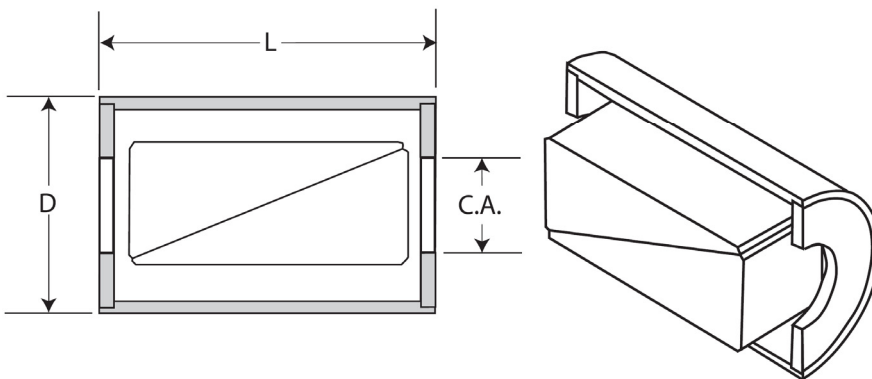



## SPECIFICATIONS

<b>Material</b>	Grade A Optical Calcite
<b>Extinction Ratio</b>	10,000:1 over central 2/3 of clear aperture
<b>Reflectance (per surface, at normal incidence)</b>	
<b>Uncoated Single layer MgF2</b>	~ 4.5% ~ 1.5%
<b>Beam Deviation</b>	± 3 arc min
<b>Acceptance Angle</b>	± 5°
<b>Wavelength Range</b>	320 – 2300 nm
<b>Recommended Safe Operating Limit</b>	25-30 W/cm <sup>2</sup> CW

## ORDERING INFORMATION

<i>Clear Aperture (mm)</i>	<i>Wavelength Range (nm)</i>	<i>AR Coating</i>	<i>Part Number</i>
5.0	320 – 2300	None	GTP – M05
5.0	400 – 700	MgF <sub>2</sub>	GTP – M05 – 0550
5.0	650 – 1000	MgF <sub>2</sub>	GTP – M05 – 0825
5.0	1000 – 1500	MgF <sub>2</sub>	GTP – M05 – 1250
8.0	320 – 2300	None	GTP – M08
8.0	400 – 700	MgF <sub>2</sub>	GTP – M08 – 0550
8.0	650 – 1000	MgF <sub>2</sub>	GTP – M08 – 0825
8.0	1000 – 1500	MgF <sub>2</sub>	GTP – M08 – 1250
10.0	320 – 2300	None	GTP – M10
10.0	400 – 700	MgF <sub>2</sub>	GTP – M10 – 0550
10.0	650 – 1000	MgF <sub>2</sub>	GTP – M10 – 0825
10.0	1000 – 1500	MgF <sub>2</sub>	GTP – M10 – 1250

**PHOTO  
TECHNICA**

[www.phototechnica.co.jp](http://www.phototechnica.co.jp)

フォトテクニカ株式会社

〒336-0017 埼玉県さいたま市南区南浦和 1-2-17

TEL: 048-871-0067 FAX: 048-871-0068

e-mail: [voc@phototechnica.co.jp](mailto:voc@phototechnica.co.jp)