

## Industrial Femtosecond Lasers

Maximum output of 120 W (IR)  
or 50 W (UV)

NEW

Single-shot – 10 MHz repetition rate

Pulse-on-demand and  
BiBurst for pulse control

Automated harmonics up to the 5<sup>th</sup>  
and wavelength-tunable extensions

Air-cooled or water-cooled models



CARBIDE-CB3

CARBIDE-CB3  
Typical pulse duration

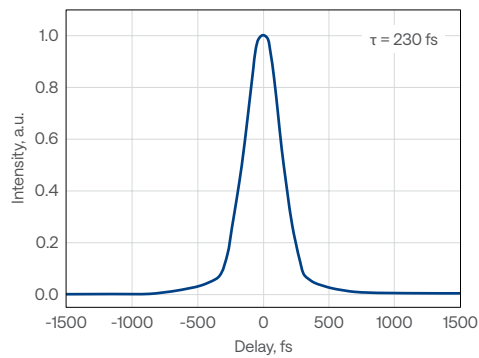

CARBIDE-CB3  
Typical spectrum

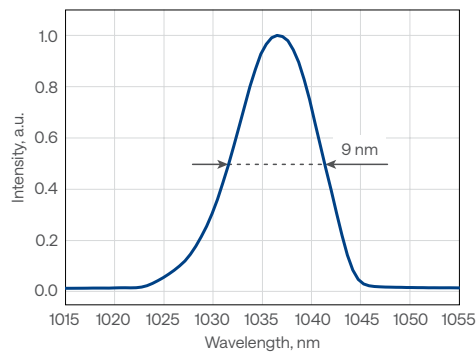

CARBIDE-CB3  
Typical beam profile

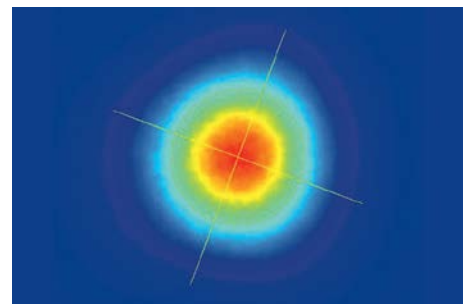

CARBIDE-CB3-120W  
Long-term power stability

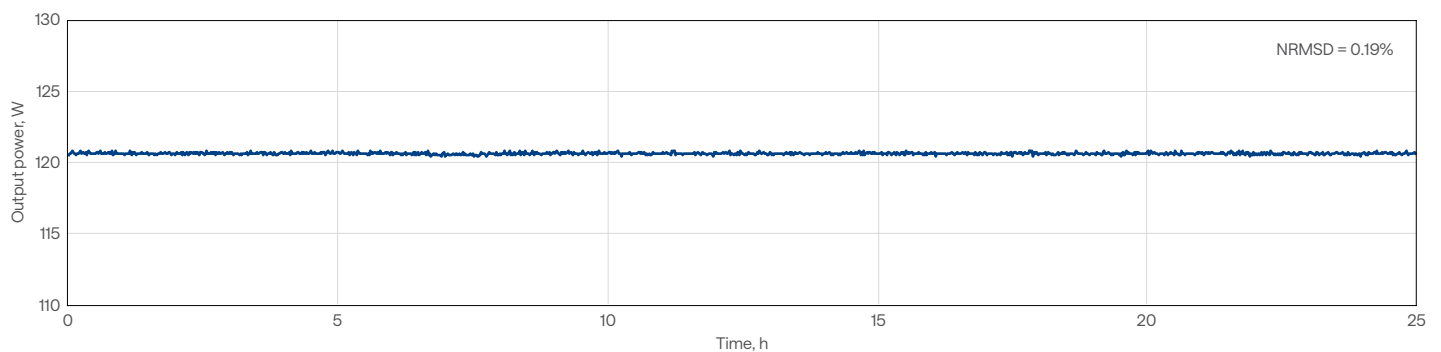



Model	CB3-20W	CB3-40W	CB3-40W-10MHz	CB3-80W	CB3-120W
-------	---------	---------	---------------	---------	----------

**OUTPUT CHARACTERISTICS**

Cooling method	Water-cooled				
Center wavelength	1030 ± 10 nm				
Maximum output power	20 W	40 W		80 W	120 W
Pulse duration <sup>1)</sup>	< 250 fs			< 350 fs <sup>2)</sup>	< 250 fs
Pulse duration tuning range	250 fs – 10 ps			350 fs – 10 ps	250 fs – 10 ps
Maximum pulse energy	0.4 mJ		0.2 mJ	0.8 mJ	2 mJ
Repetition rate	Single-shot – 1 MHz	Single-shot – 1 MHz (2 MHz on request)	Single-shot – 10 MHz	Single-shot – 2 MHz	
Pulse selection	Single-shot, pulse-on-demand, any fundamental repetition rate division				
Polarization	Linear, vertical; 1:1000				
Beam quality, M <sup>2</sup>	< 1.2				
Beam diameter <sup>3)</sup>	3.9 ± 0.4 mm			4.2 ± 0.4 mm	5.1 ± 0.7 mm
Beam pointing stability	< 20 µrad/°C				
Pulse energy control	FEC <sup>4)</sup>		Attenuator <sup>5)</sup>	FEC <sup>4)</sup>	
Pulse picker leakage	< 0.25%		< 0.5%	< 0.25%	
Pulse-to-pulse energy stability, 12 h <sup>6)</sup>	< 0.5%				
Long-term power stability, 100 h <sup>6)</sup>	< 0.5%				

**MAIN OPTIONS**

Oscillator output <sup>7)</sup>	< 0.5 W, 120 – 250 fs, 1030 ± 10 nm, ≈ 65 MHz				
Harmonic generator <sup>8)</sup>	515 nm, 343 nm, 257 nm, or 206 nm; refer to CARBIDE HG				
Optical parametric amplifier <sup>9)</sup>	UV – MIR; refer to I-OPA or ORPHEUS				
BiBurst option	Tunable GHz and MHz burst with burst-in-burst capability; refer to BiBurst				

**PHYSICAL DIMENSIONS**

Laser head (L × W × H)	633 × 350 × 174 mm				
Chiller (L × W × H)	585 × 484 × 221 mm		680 × 484 × 307 mm		
24 V DC power supply (L × W × H)	352 × 195 × 75 mm				376 × 449 × 88 mm

**ENVIRONMENTAL AND UTILITY REQUIREMENTS**

Operating temperature	15 – 30 °C				
Relative humidity	< 80% (non-condensing)				
Electrical requirements	Laser	100 V AC, 7 A – 240 V AC, 3 A; 50 – 60 Hz	100 V AC, 12 A – 240 V AC, 5 A; 50 – 60 Hz	100 V AC, 15 A – 240 V AC, 7 A; 50 – 60 Hz	
	Chiller	100 – 230 V AC; 50 – 60 Hz	200 – 230 V AC; 50 – 60 Hz		
Rated power	Laser	1000 W	1000 W	2000 W	
	Chiller	1400 W	2000 W		
Power consumption	Laser	500 W	900 W	1500 W	
	Chiller	1000 W	1300 W	1800 W	

<sup>1)</sup> Assuming a Gaussian pulse shape.  
<sup>2)</sup> Pulse duration can be reduced to < 250 fs if a pulse peak intensity of > 50 GW/cm<sup>2</sup> is tolerated by the customer setup.  
<sup>3)</sup> FW 1/e<sup>2</sup>, using maximum pulse energy.  
<sup>4)</sup> Fast energy control (FEC) provides fast, full-scale individual pulse energy control; an external analog control input is available.  
<sup>5)</sup> Waveplate-based variable optical attenuator (VOA); an external analog control input is available. FEC is available for repetition rates up to 2 MHz.

<sup>6)</sup> Under stable environmental conditions. Expressed as normalized root mean squared deviation (NRMSD).  
<sup>7)</sup> Available simultaneously, requires a scientific interface. Contact sales@lightcon.com for more details or customized solutions.  
<sup>8)</sup> Integrated. For an external harmonic generator, refer to HIRO.  
<sup>9)</sup> Integrated. For more details and stand-alone OPAs, refer to wavelength-tunable sources.

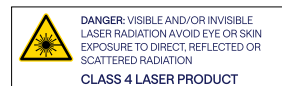

Model	CB5-6W	CB5-5W	CB5-SP
-------	--------	--------	--------

**OUTPUT CHARACTERISTICS**

Cooling method	Air-cooled <sup>1)</sup>		
Center wavelength	1030 ± 10 nm		
Maximum output power	6 W	5 W	
Pulse duration <sup>2)</sup>	< 290 fs		< 190 fs
Pulse duration tuning range	290 fs – 20 ps		190 fs – 20 ps
Maximum pulse energy	100 µJ	83 µJ	100 µJ
Repetition rate	Single-shot – 1 MHz		
Pulse selection	Single-shot, pulse-on-demand, any fundamental repetition rate division		
Polarization	Linear, vertical; 1:1000		
Beam quality, M <sup>2</sup>	< 1.2		
Beam diameter <sup>3)</sup>	2.1 ± 0.4 mm		
Beam pointing stability	< 20 µrad/°C		
Pulse energy control	Attenuator <sup>4)</sup>	AOM <sup>5)</sup>	Attenuator <sup>4)</sup>
Pulse picker leakage	< 2%	< 0.1%	< 2%
Pulse-to-pulse energy stability, 12 h <sup>6)</sup>	< 0.5%		
Long-term power stability, 100 h <sup>6)</sup>	< 0.5%		

**MAIN OPTIONS**

Oscillator output	n/a		
Harmonic generator <sup>7)</sup>	515 nm, 343 nm, 257 nm, or 206 nm; refer to CARBIDE HG		
Optical parametric amplifier <sup>8)</sup>	UV – MIR; refer to I-OPA or ORPHEUS		
BiBurst option	n/a		

**PHYSICAL DIMENSIONS**

Laser head (L × W × H)	633 × 324 × 162 mm		
Chiller	Not required		
24 V DC power supply (L × W × H)	220 × 95 × 46 mm		

**ENVIRONMENTAL AND UTILITY REQUIREMENTS**

Operating temperature	17 – 27 °C		
Relative humidity	< 80% (non-condensing)		
Electrical requirements	100 V AC, 3 A – 240 V AC, 1.3 A; 50 – 60 Hz		
Rated power	300 W		
Power consumption	150 W		

<sup>1)</sup> Water-cooled version available on request.

<sup>2)</sup> Assuming a Gaussian pulse shape.

<sup>3)</sup>  $FW\ 1/e^2$ , using maximum pulse energy.

<sup>4)</sup> Waveplate-based variable optical attenuator (VOA); an external analog control input is available.

<sup>5)</sup> Enhanced contrast AOM. Provides fast, full-scale individual pulse energy control; an external analog control input is available.

<sup>6)</sup> Under stable environmental conditions. Expressed as normalized root mean squared deviation (NRMSD).

<sup>7)</sup> Integrated. For an external harmonic generator, refer to HIRO.

<sup>8)</sup> Integrated. For more details and stand-alone OPAs, refer to wavelength-tunable sources.

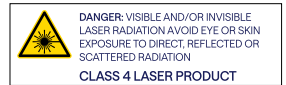

**CARBIDE-CB5**  
Typical pulse duration

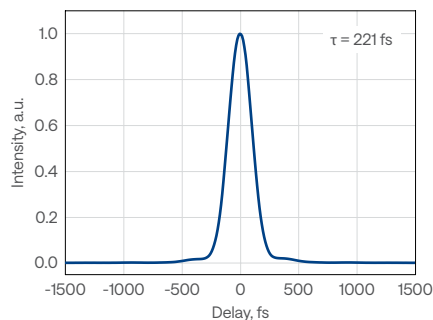

**CARBIDE-CB5**  
Typical spectrum

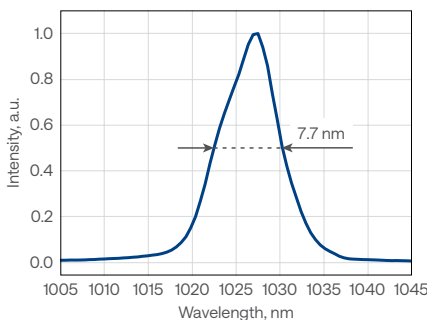

**CARBIDE-CB5**  
Typical beam profile

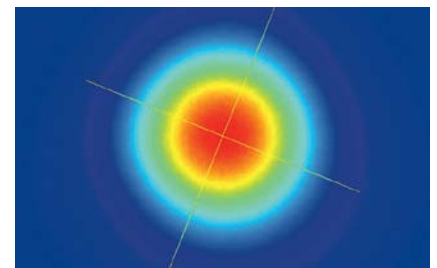

**CARBIDE-CB3** output power and beam direction stability with power lock enabled, across varying environmental conditions

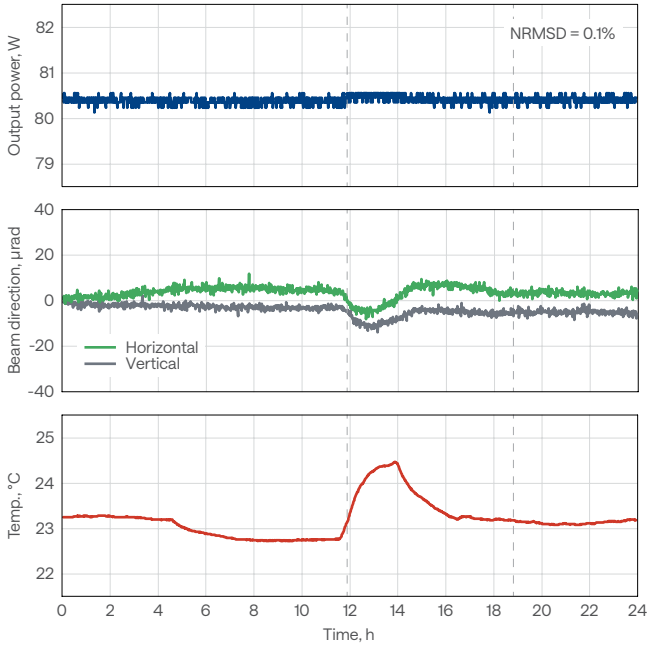

**CARBIDE-CB3**  
Typical pulse-to-pulse energy stability

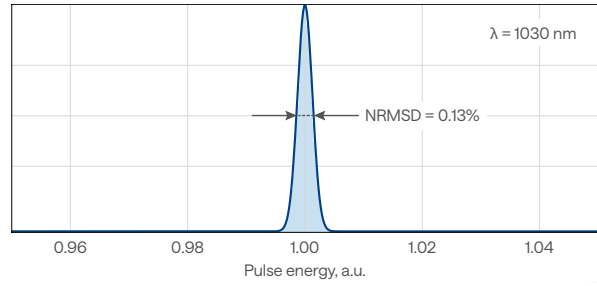

**CARBIDE-CB5-6W**  
Long-term power stability

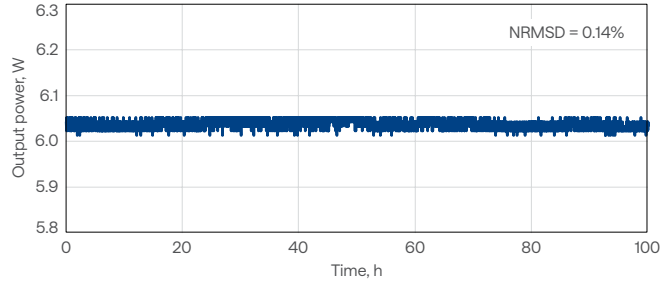

## Drawings

**CARBIDE-CB3**

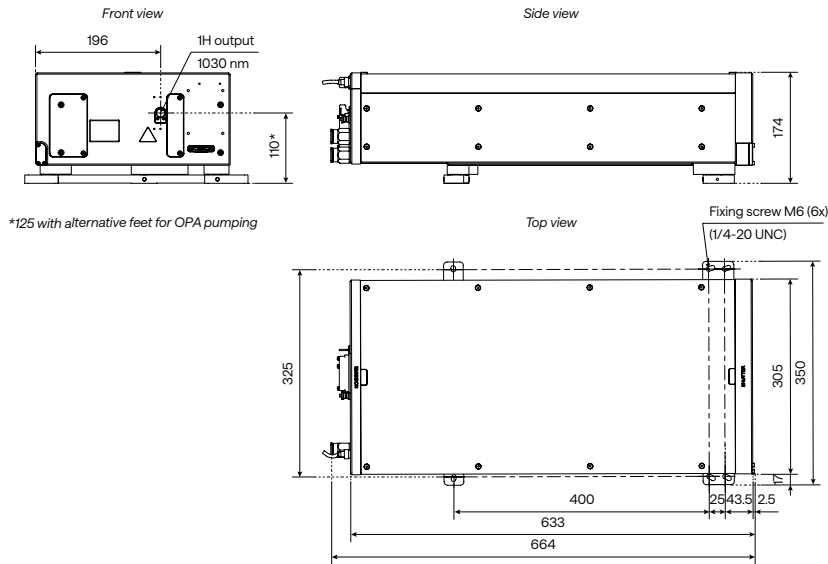

Air-cooled **CARBIDE-CB5** with an attenuator

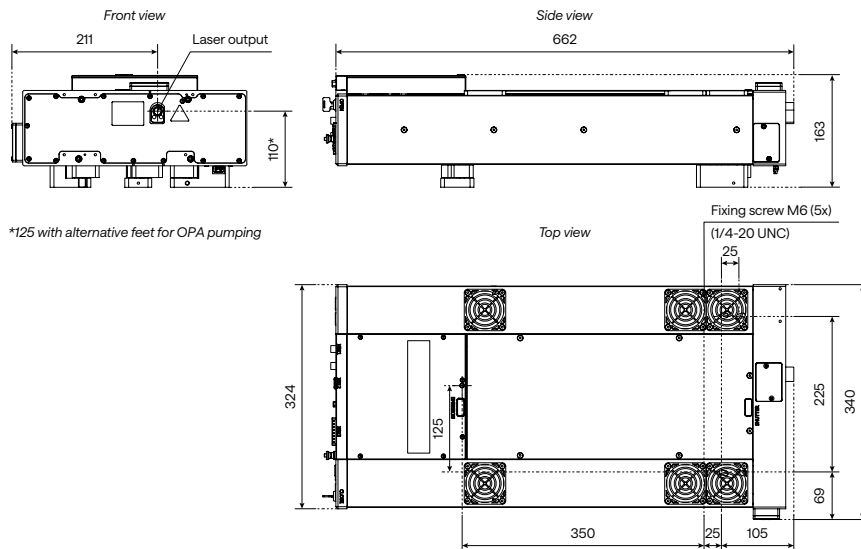

The drawings depend on the exact configuration. If crucial for integration, please contact [sales@lightcon.com](mailto:sales@lightcon.com).

REV. 260101 | [SALES@LIGHTCON.COM](mailto:SALES@LIGHTCON.COM)



# CARBIDE | CB3-UV

## High-Power UV Femtosecond Lasers

NEW

Maximum output of 50 W

500 fs pulse duration

Up to MHz repetition rate

High beam quality and stability

Compact industrial-grade design



CARBIDE-CB3-UV  
Typical spectrum

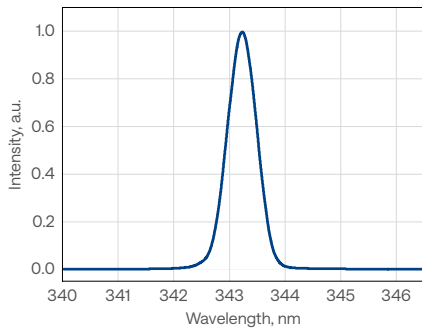

CARBIDE-CB3-UV  
Typical M<sup>2</sup> measurement data

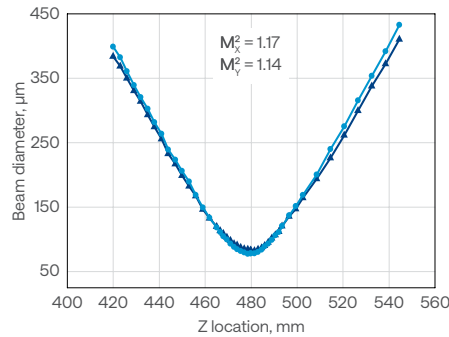

CARBIDE-CB3-UV  
Beam profile

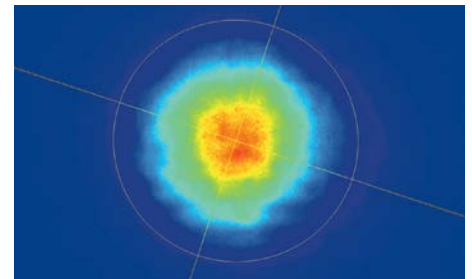

CARBIDE-CB3-UV-50W  
Long-term power stability

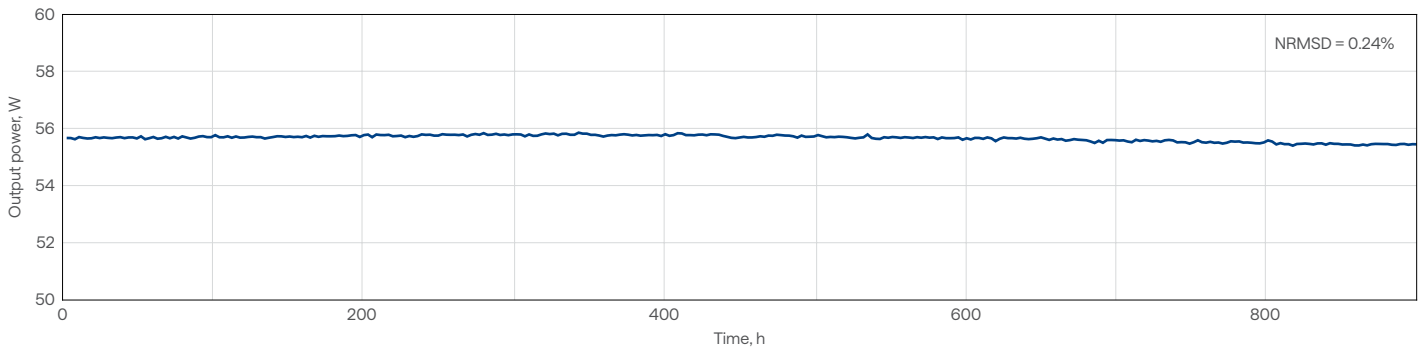

# Specifications

Model	CB3-UV-30W	CB3-UV-50W
-------	------------	------------

## OUTPUT CHARACTERISTICS

Cooling method	Water-cooled	
Center wavelength	343 ± 3 nm	
Output power	> 30 W	> 50 W
Pulse duration <sup>1)</sup>	≈ 500 fs	
Maximum output pulse energy <sup>2)</sup>	150 μJ	
Repetition rate <sup>3)</sup>	200 – 1000 kHz	300 – 1000 kHz
Polarization	Linear, vertical; 1 : 200	
Beam quality, M <sup>2</sup> , typical values	< 1.3	
Beam diameter <sup>4)</sup>	2 – 5 mm	
Long-term power stability, 12 h <sup>5)</sup>	< 0.5%	
Lifetime	10 000 h	

## MAIN OPTIONS

Optional amplifier outputs	1030 nm, 515 nm
----------------------------	-----------------

## PHYSICAL DIMENSIONS

Laser head (L × W × H)	801 × 350 × 174 mm
Chiller (L × W × H)	680 × 484 × 307 mm
24 V DC power supply (L × W × H)	352 × 195 × 75 mm

## ENVIRONMENTAL AND UTILITY REQUIREMENTS

Operating temperature	15 – 30 °C		
Relative humidity	< 80% (non-condensing)		
Electrical requirements	Laser	100 V AC, 12 A – 240 V AC, 5 A; 50 – 60 Hz	100 V AC, 15 A – 240 V AC, 7 A; 50 – 60 Hz
	Chiller	200 – 230 V AC; 50 – 60 Hz	
Rated power	Laser	1000 W	2000 W
	Chiller	2000 W	
Power consumption	Laser	900 W	1500 W
	Chiller	1300 W	1800 W

<sup>1)</sup> Assuming a Gaussian pulse shape.

<sup>2)</sup> Depends on the pump energy.

<sup>3)</sup> Repetition rate available up to 2 MHz at lower power.

<sup>4)</sup> FW 1/e<sup>2</sup>; depends on the pump energy.

<sup>5)</sup> Under stable environmental conditions. Expressed as normalized root mean squared deviation (NRMSD).

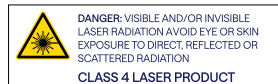

# Drawings

## CARBIDE-CB3-UV

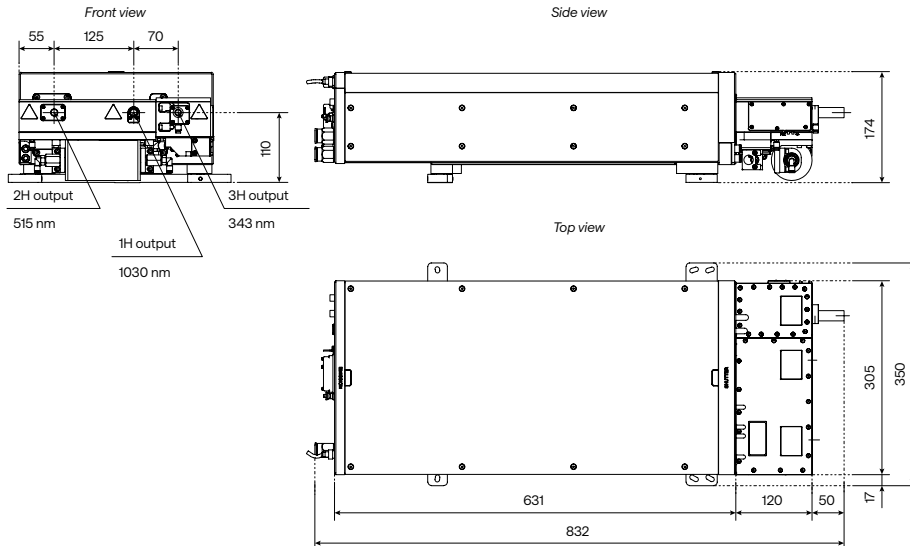

## Integrated Harmonic Generators

515 nm, 343 nm, 257 nm,  
or 206 nm output

Automated harmonic selection

Mounted directly on the laser head



CARBIDE-CB3  
with a 2H-3H module

### Specifications

Model	2H	2H-3H	2H-4H	2H-5H	30W UV <sup>1)</sup>	50W UV <sup>1)</sup>
Output wavelength <sup>2)</sup> (automated selection)	1030 nm 515 nm	1030 nm 515 nm 343 nm	1030 nm 515 nm 257 nm	1030 nm 515 nm 206 nm	1030 nm 515 nm 343 nm	1030 nm 515 nm 343 nm
Pump pulse energy	20 – 2000 $\mu$ J	50 – 2000 $\mu$ J	20 – 2000 $\mu$ J	100 – 1500 $\mu$ J	80 – 400 $\mu$ J	120 – 400 $\mu$ J
Pump pulse duration	< 300 fs				$\approx$ 500 fs	
Conversion efficiency / Output power	> 50% (2H)	> 50% (2H) > 25% (3H)	> 50% (2H) > 10% (4H) <sup>3)</sup>	> 50% (2H) > 5% (5H) <sup>4)</sup>	30 W (3H)	50 W (3H)
Beam quality, M <sup>2</sup>	$\leq$ 400 $\mu$ J pump	< 1.3 (2H) < 1.4 (3H)	< 1.3 (2H) n/a (4H)	n/a	< 1.3 (3H)	< 1.3 (3H)
	> 400 $\mu$ J pump	< 1.4 (2H)	< 1.4 (2H) < 1.5 (3H)	n/a (4H)	n/a	

<sup>1)</sup> Refer to CARBIDE-CB3-UV for more details.

<sup>2)</sup> Depends on the pump laser model. Up to the 5<sup>th</sup> harmonic available; contact sales@lightcon.com for more details.

<sup>3)</sup> Maximum output power of 5 W.

<sup>4)</sup> Maximum output power of 0.2 W.

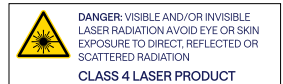

CARBIDE-CB5 (100 kHz, 6 W)  
Typical 1H beam profile

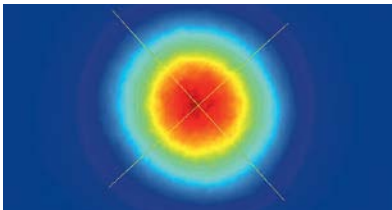

CARBIDE-CB5 (100 kHz, 3.4 W)  
Typical 2H beam profile

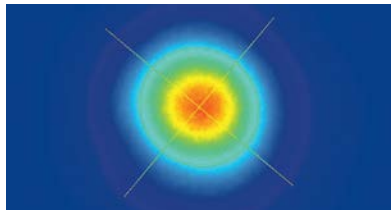

CARBIDE-CB5 (100 kHz, 2.2 W)  
Typical 3H beam profile

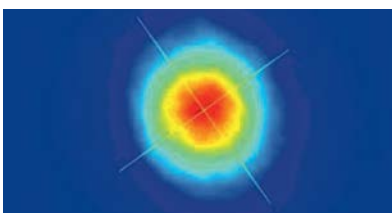

CARBIDE-CB5 (100 kHz, 100 mW)  
Typical 4H beam profile

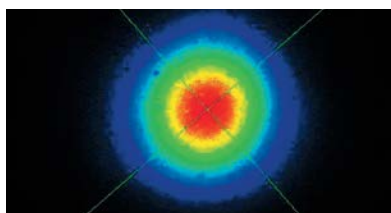

CARBIDE-CB3-80W with a harmonic generator  
Pulse energy vs repetition rate

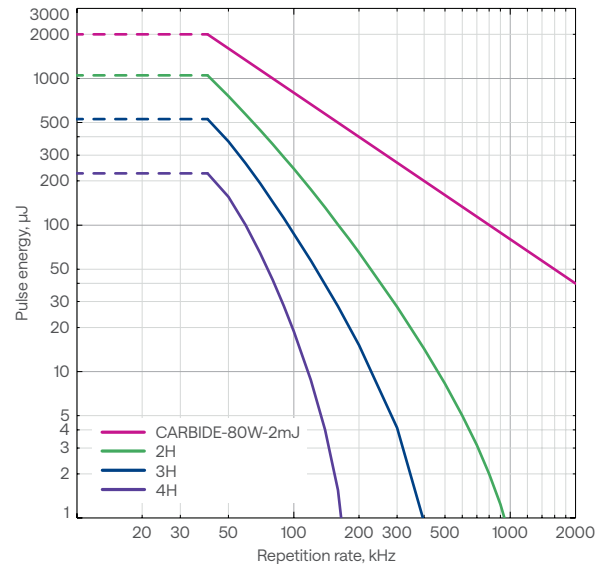

# I-OPA

## Industrial-Grade Optical Parametric Amplifier

Wavelength tunability in an industrial design

Single-box solution

Tunable or fixed-wavelength models

Plug-and-play installation and robust performance

The most compact OPA in the market

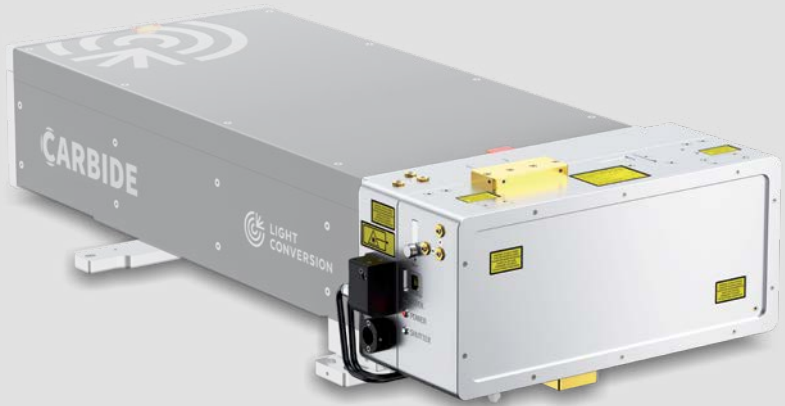

CARBIDE-CB3 with I-OPA-HP

I-OPA-HP typical tuning curves  
Pump: 40 W, 400  $\mu$ J, 100 kHz

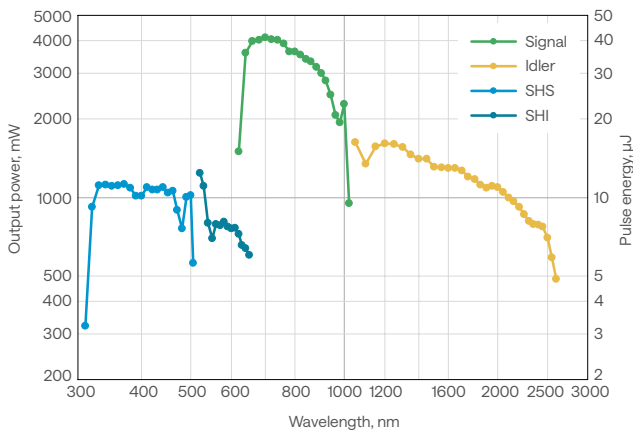

I-OPA-F typical tuning curves  
Pump: 40 W, 400  $\mu$ J, 100 kHz

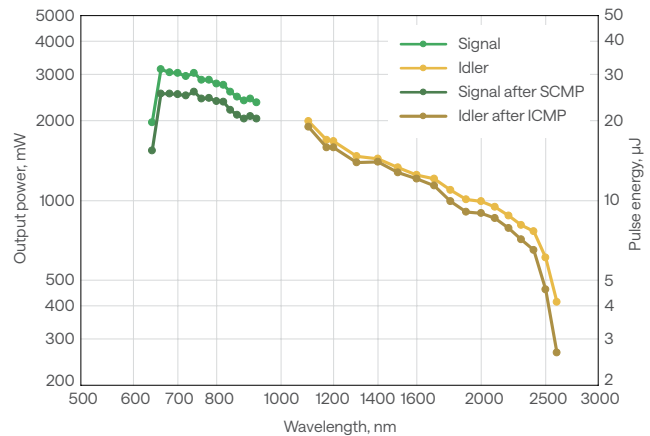

I-OPA-HP  
Typical power stability at 1300 nm

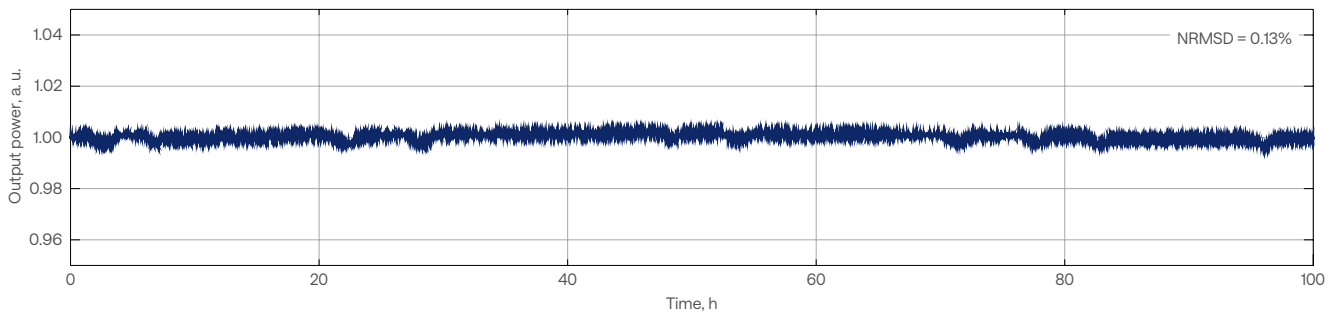

# Specifications

Model	I-OPA-HP	I-OPA-F	I-OPA-ONE
Configuration	ORPHEUS	ORPHEUS-F	ORPHEUS-ONE
Pump power	Up to 40 W		
Pump pulse energy	20 – 400 $\mu$ J		
Repetition rate	Up to 2 MHz		
Tuning range <sup>1)</sup>	640 – 1010 nm (signal) 1050 – 2600 nm (idler)	650 – 920 nm (signal) 1200 – 2500 nm (idler)	1350 – 2000 nm (signal) 2100 – 4500 nm (idler)
Conversion efficiency	> 7% @ 700 nm (40 – 400 $\mu$ J pump; up to 1 MHz)		> 9% @ 1550 nm (40 – 400 $\mu$ J pump; up to 1 MHz)
	> 3.5% @ 700 nm (20 – 40 $\mu$ J pump; up to 2 MHz)		> 6% @ 1550 nm (20 – 40 $\mu$ J pump; up to 2 MHz)
Spectral bandwidth <sup>2)</sup>	80 – 220 $\text{cm}^{-1}$ @ 700 – 960 nm	200 – 1000 $\text{cm}^{-1}$ @ 650 – 920 nm 150 – 1000 $\text{cm}^{-1}$ @ 1200 – 2000 nm	60 – 150 $\text{cm}^{-1}$ @ 1450 – 2000 nm
Pulse duration <sup>2) 3)</sup>	120 – 250 fs	< 55 fs @ 800 – 920 nm < 70 fs @ 650 – 800 nm < 100 fs @ 1200 – 2000 nm	100 – 300 fs
Long-term power stability, 8 h <sup>4)</sup>	< 1% @ 800 nm		< 1% @ 1550 nm
Pulse-to-pulse energy stability, 1 min <sup>4)</sup>	< 1% @ 800 nm		< 1% @ 1550 nm
Wavelength extension options	320 – 505 nm (SHS) <sup>5)</sup> 525 – 640 nm (SHI) <sup>5)</sup>	Contact sales@lightcon.com	4500 – 10 000 nm (DFG)
Pulse compression options <sup>2)</sup>	n/a	SCMP (signal pulse compressor) ICMP (idler pulse compressor)	n/a

## PUMP LASER REQUIREMENTS

Pump laser	CARBIDE or PHAROS
Center wavelength	1030 $\pm$ 10 nm
Maximum pump power	40 W
Maximum repetition rate	Up to 2 MHz
Pump pulse energy	20 – 400 $\mu$ J
Pulse duration	180 – 300 fs

## ENVIRONMENTAL & UTILITY REQUIREMENTS

Refer to lightcon.com

<sup>1)</sup> In the case of a fixed wavelength (FW), a single wavelength can be selected from the signal or idler range. The signal may have an accessible idler pair, and vice versa.

<sup>2)</sup> I-OPA-F broad-bandwidth pulses are compressed externally. Typical pulse duration before compression: 120 – 250 fs, after compression: 25 – 70 fs @ 650 – 920 nm, 40 – 100 fs @ 1200 – 2000 nm.

<sup>3)</sup> Output pulse duration depends on the selected wavelength and the pump laser pulse duration.

<sup>4)</sup> Expressed as normalized root mean squared deviation (NRMSD).

<sup>5)</sup> Conversion efficiency is 1.2% at peak; specified as a percentage of pump power.

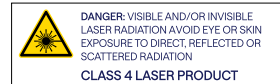

## Drawings

### CARBIDE-CB3 with I-OPA-HP

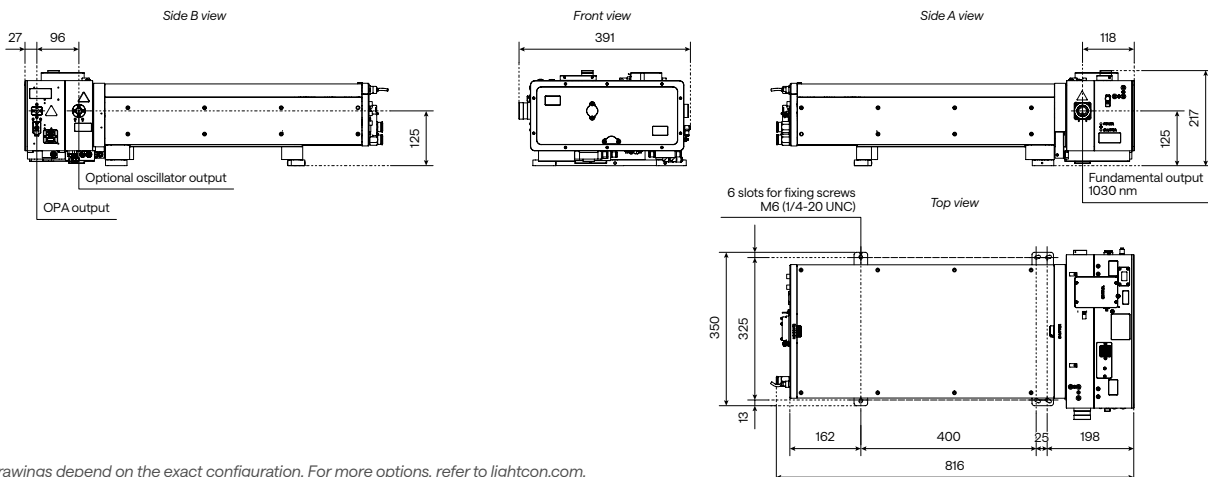

The drawings depend on the exact configuration. For more options, refer to lightcon.com.



# SCI-M | CARBIDE

## Scientific Interface Module for CARBIDE

Simultaneous or separate oscillator output

Uncompressed laser output

Seeding by an external oscillator

Beam-splitting for multiple outputs



### Drawings

CARBIDE-CB3-40W with a scientific interface module

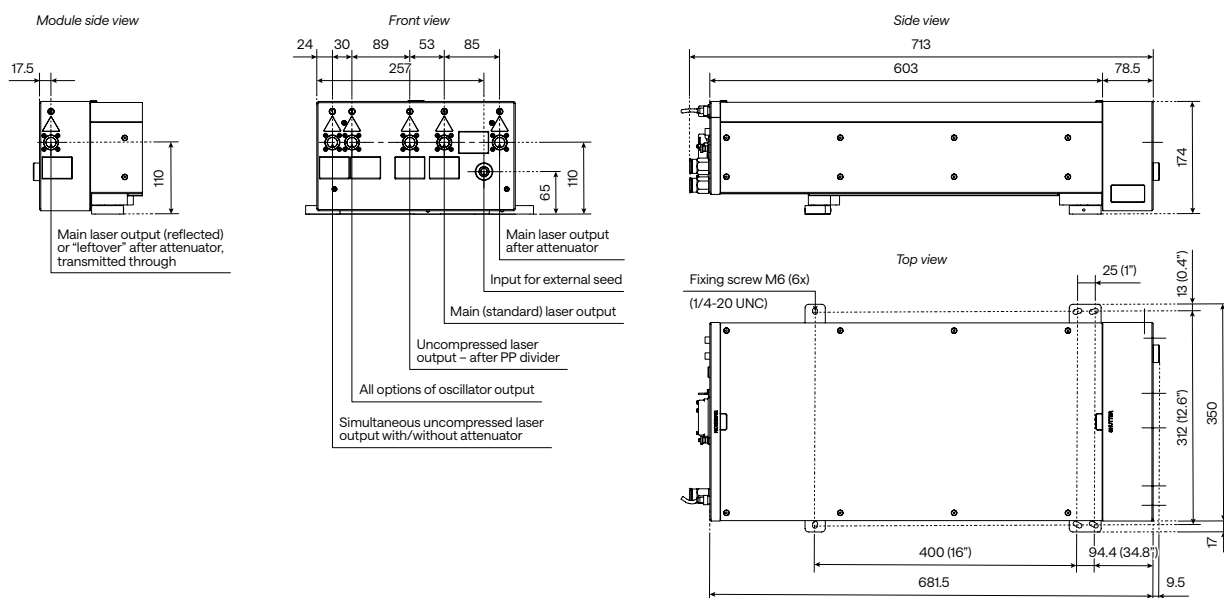

# BiBurst

## Tunable GHz and MHz Burst with Burst-in-Burst Capability

Water-cooled **CARBIDE** and **PHAROS** lasers feature the tunable GHz and MHz burst option with burst-in-burst capability, known as BiBurst.

In standard mode, the laser emits a single pulse at a fixed frequency. In burst mode, the output consists of pulse packets instead of single pulses. Each packet consists of a specific number of equally separated pulses. MHz-Burst contains N pulses with a nanosecond period, while GHz-Burst contains P pulses with a picosecond period. When both burst modes are combined, the equally separated pulse packets contain sub-packets of pulses, forming the burst-in-burst or BiBurst.

**CARBIDE** and **PHAROS** lasers, equipped with tunable GHz and MHz bursts and BiBurst options, bring new capabilities to high-tech

manufacturing industries, such as consumer electronics, integrated photonic chip production, advanced display manufacturing, and quantum technologies.

Applications:

- Brittle material drilling and cutting
- Deep engraving
- Selective ablation
- Volume modification of transparent materials
- Hidden marking
- Surface polishing
- Functional surface structuring

### Specifications

Model		CARBIDE-CB3	PHAROS
GHz Burst	Intra burst pulse period <sup>1)</sup>	440 ± 40 ps	200 ± 40 ps
	Number of pulses, P <sup>2)</sup>	1 – 10 (up to 400) <sup>3)</sup>	1 – 25
MHz Burst	Intra burst pulse period	≈ 15 ns	
	Number of pulses, N <sup>2)</sup>	1 – 10	1 – 9 (7 with FEC) <sup>4)</sup>

<sup>1)</sup> Custom spacing is available on request. For CARBIDE-CB3-10MHz model standard pulse period is 1500 ps.

<sup>2)</sup> The maximum number of pulses in a burst depends on the laser repetition rate and energy. CARBIDE-CB3-10MHz model is limited up to 5 pulses.

<sup>3)</sup> The maximum number of P pulses can be increased to 350 – 400 with optional long GHz burst mode.

<sup>4)</sup> Fast energy control option. Enables formation of any pulse envelope at laser pulse repetition rate.

