

## Diode-pumped Picosecond Passively Q-Switched Lasers



QS Lasers offers a series of compact DPSS passively Q-switched picosecond lasers, meticulously engineered for seamless OEM integration and high-volume production. Despite their small footprint, these lasers deliver outstanding pulse-to-pulse stability and superior performance for demanding applications across a variety of industries.

### Features

- Up to 3 mJ pulse energy at 1064 nm
- 250–800 ps pulse duration
- 1–100 Hz repetition rate
- Compact, hermetically sealed design
- Low jitter <2  $\mu$ s
- Guaranteed >3 Gshot lifetime
- Simultaneous or discrete 532 nm, 355 nm output options

### Applications

- Seeder for amplifier
- Laser-induced breakdown spectroscopy (LIBS) and imaging
- Laser flash photolysis
- Time resolved fluorescence measurements
- DNA analysis
- Pollution monitoring
- Supercontinuum generation
- Time gated Raman spectroscopy
- Ultrasonic wave generation

MPL231 Typical energy output

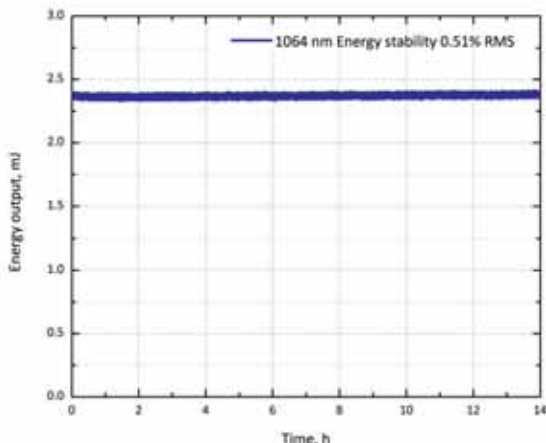

MPL231 Typical pulse duration

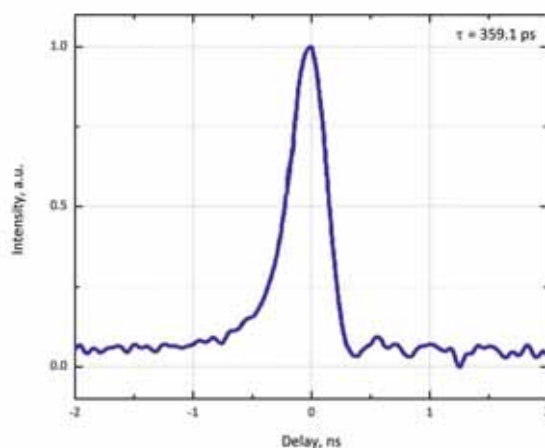

# Specifications <sup>1</sup>

		MPL111	MPL121	MPL131	MPL211	MPL221	MPL231	MPL310	MPL320	MPL330
<b>Output characteristics</b>										
Pulse energy (mJ)	1064 nm	1			2			3		
	532 nm	0.5			1			1.5		
	355 nm	0.25			0.5			0.6		
Pulse duration <sup>2</sup> (ps)		250	350	500	250	350	500	250	350	500
Pulse repetition <sup>3</sup> (Hz)		1-100						1-10		
Pulse-to-pulse energy stability <sup>4</sup> (% RMS)	1064 nm				<1					
	532 nm				<2					
	355 nm				<3					
Power drift <sup>5</sup> (% RMS)					±3					
Optical pulse jitter <sup>6</sup> (µs RMS)					~2					
Beam divergence <sup>7</sup> (mrad)					<6					
Beam diameter <sup>8</sup> (mm)	1064 nm				1.5					
	532 nm				1					
	355 nm				1					
Pointing stability, full angle (µrad)					<50					
Polarization					linear, horizontal					
Triggering modes					internal / external					
Beam spatial profile					close-to-Gaussian in near and far fields					
<b>Dimensions W x L x H (mm)   Standalone version</b>										
Laser head					138 x 200 x 89					
with 2 <sup>nd</sup> harmonic output					138 x 200 x 89					
with 3 <sup>rd</sup> , 2 <sup>nd</sup> /3 <sup>rd</sup> harmonic output					138 x 295 x 89					
Laser controller					260 x 333 x 150					
<b>Dimensions W x L x H (mm)   OEM version</b>										
Laser head					99 x 175 x 45.5					
Laser controller					136 x 261 x 127					
<b>Operating requirements</b>										
Electrical requirements					100-240 V AC, single phase 50-60 Hz					
Power consumption					<50 W					
Cooling system					TEC					
Ambient temperature					20-30 °C					
Relative humidity					10-80% (non-condensing)					

\* Customized models available on request

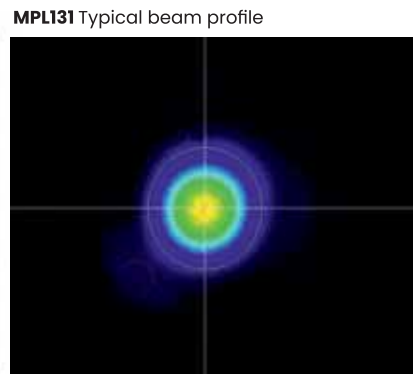
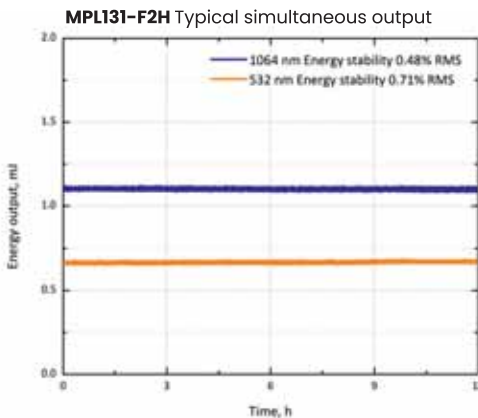

<sup>1</sup> Due to continuous improvements all specifications are subject to change. Unless stated otherwise all specifications are measured at 1064 nm and 100 Hz.  
<sup>2</sup> FWHM level at 1064 nm.  
<sup>3</sup> Factory-set pulse repetition rate is set at 100 Hz.  
<sup>4</sup> Averaged from 30 second time interval in 5 series.  
<sup>5</sup> Over 8 hours when temperature variation is ±2 °C.  
<sup>6</sup> In respect to q-switch sync. signal in internal trigger mode, rising edge of TTL-sync. out signal. Internal trigger mode delivers TTL-sync. out signal.  
<sup>7</sup> Full angle measured at 1/e<sup>2</sup> level; can be adjusted to customer requirements, please inquiry for more details.  
<sup>8</sup> Beam diameter is measured 20 cm from laser output at 1/e<sup>2</sup> level.

**OEM version**

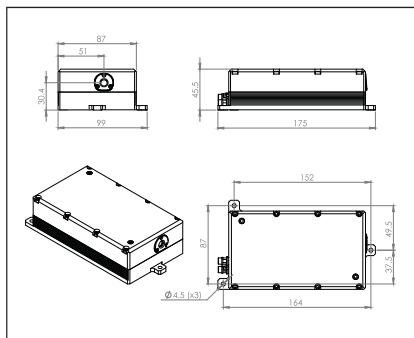

**Standalone version**

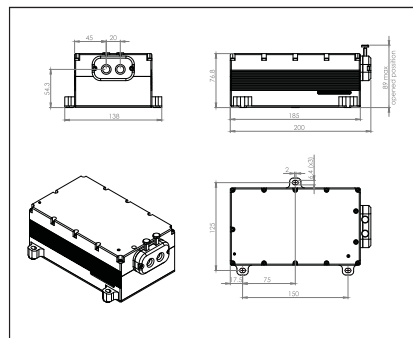

**Standalone version**

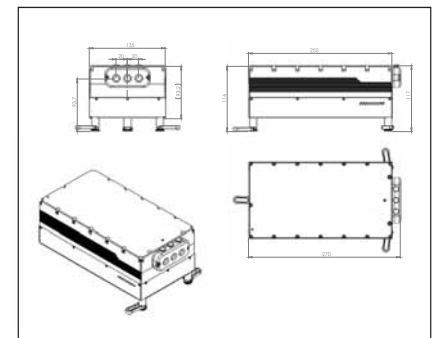

## Diode-pumped Picosecond Actively Q-Switched Lasers



Actively Q-switched DPSS picosecond laser series by QS Lasers is reliable and precision-driven solution for demanding applications across industrial, scientific, and research fields. Its innovative laser cavity design ensures exceptionally stable output parameters, all within the compact size of the device. The air-cooled design further contributes to its energy-efficient operation and smooth integration to OEM systems.

### Features

- Up to 2 mJ pulse energy at 1064 nm
- 500-700 ps pulse duration
- Single-shot to 1 kHz repetition rate
- Compact, hermetically sealed design
- Ultra-low jitter <0.2 ns
- Guaranteed >3 Gshot lifetime
- Simultaneous or discrete 532 nm, 355 nm output options

### Applications

- Seeder for amplifier
- Laser-induced breakdown spectroscopy (LIBS) and imaging
- Laser flash photolysis
- Time resolved fluorescence measurements
- Time of flight measurements
- Pollution monitoring
- Light detection and ranging (LiDAR)
- Supercontinuum generation
- Raman spectroscopy

**APL331-F2H/3H** Typical simultaneous output

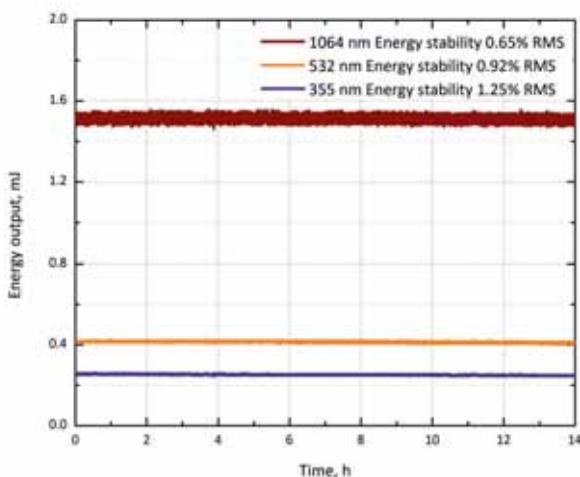

**APL220** Typical pulse duration

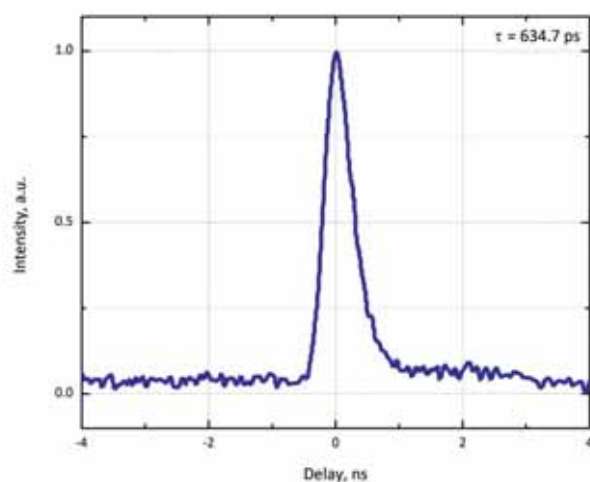

# Specifications<sup>1</sup>

	APL120	APL220	APL320	APL131	APL231	APL331
<b>Output characteristics</b>						
Pulse energy at 1064 nm (mJ)	0.5	1	2	0.5	1	1.5
Pulse duration <sup>2</sup> (ps)	500-700			700		
Pulse repetition <sup>3</sup> (Hz)	1-100			1000		
Pulse-to-pulse energy stability <sup>4</sup> (% RMS)	1064 nm	<1				
	532 nm	<1.5				
	355 nm	<2				
Power drift <sup>5</sup> (% RMS)	±3					
Optical pulse jitter <sup>6</sup> (ns RMS)	0.2					
Beam divergence <sup>7</sup> (mrad)	<5					
Beam diameter <sup>8</sup> (mm)	1.2					
Pointing stability, full angle (μrad)	<50					
Polarization	linear, horizontal at 1064 & 532 nm, vertical at 355 nm					
Triggering modes	internal / external					
Beam spatial profile	close-to-Gaussian in near and far fields					
<b>Dimensions W x L x H (mm)</b>						
Laser head	135 x 270 x 70			135 x 270 x 117		
Laser controller	260 x 333 x 150					
<b>Operating requirements</b>						
Electrical requirements	100-240 V AC, single phase 50-60 Hz					
Power consumption	<50 W			<200 W		
Cooling system	TEC					
Ambient temperature	20-30 °C					
Relative humidity	10-80% (non-condensing)					

\* Customized models available on request

APL331-3H Typical energy output

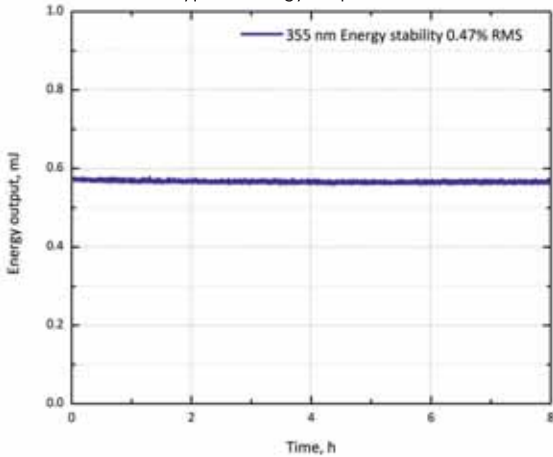

APL331 Typical beam profile

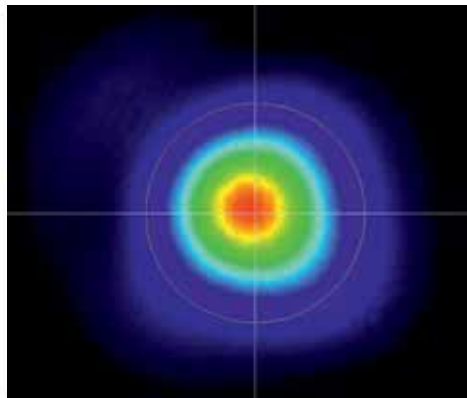

<sup>1</sup> Due to continuous improvements all specifications are subject to change. Unless stated otherwise all specifications are measured at 1064 nm and 100 Hz.

<sup>2</sup> FWHM level at 1064 nm.

<sup>3</sup> Factory-set pulse repetition rate is set at 100 Hz.

<sup>4</sup> Averaged from 30 second time interval in 5 series.

<sup>5</sup> Over 8 hours when temperature variation is ±2 °C.

<sup>6</sup> In respect to q-switch sync. signal in internal trigger mode, rising edge of TTL-sync. out signal. Internal trigger mode delivers TTL-sync. out signal.

<sup>7</sup> Full angle measured at 1/e<sup>2</sup> level; can be adjusted to customer requirements, please inquiry for more details.

<sup>8</sup> Beam diameter is measured 20cm from laser output at 1/e<sup>2</sup> level.

100 Hz version

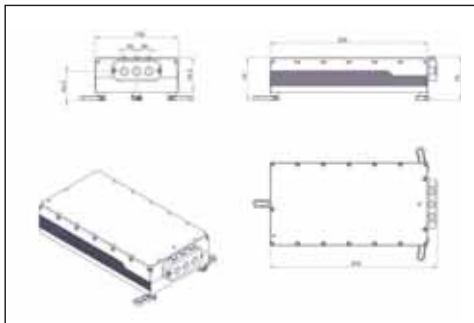

1 kHz version with a heatsink

