

SPIDER Pulse Characterization

Spectral and Temporal Characterization of Ultrashort Laser Pulses

The Spider series by APE is an all-purpose and frequently used solution for complete characterization of ultrashort laser pulses. Even complex pulse shapes can be measured rapidly and at fast update rates. Different models are available to cover various pulse widths, bandwidths, and wavelengths.

The FC Spider (Few Cycle Spider) is the best choice for very short pulses down to sub 5 fs and supports pulse spectra that cover up to one octave.

The Spider IR is ideal for infrared laser pulses with a central wavelength of around 0.8 or 1 μm .

FC Spider

- Measurement of very short pulses with only a few cycles



Spider

- Measurement at central wavelengths of around 0.8 or 1 μm



Spider Software

Spider Software Features

Important software features for advanced pulse characterization are provided with all APE Spiders. If desired, a PC or notebook with pre-installed software can optionally be delivered together with the instrument.



Software Interface FC Spider and Spider

FC Spider, Spider (Software)

- Spectral and temporal reconstruction
- E-field plot
- Peak power calculation
- Measurement of phase differences
- Spectral phase analysis up to fourth order
- Simulation of additional theoretical dispersion (GDD, TOD, FOD)
- Spectrogram (X-FROG, SHG-FROG) and Wigner trace representation of the pulse

FC Spider Few Cycles

Precise Characterization of Very Short Pulses Down to <math><5\text{ fs}</math>

The FC Spider (Few Cycle Spider) by APE provides spectral and temporal characterization of ultrashort laser pulses down to below 5 fs. It covers the infrared and near-infrared ranges as well as the visible wavelength range with the FC Spider VIS.

This high precision tool is ideal for aligning and monitoring the performance of broadband Ti:Sa oscillators and amplifier chains.

The FC Spider VIS supports the visible spectral region down to 450 nm, suitable for characterization of e.g. nonlinear optical parametric amplifiers (NOPA).

Based on the proven and patented SPIDER* technology, using a non-drifting, etalon interferometer and a material dispersion stretcher, the FC Spider directly measures the spectral phase by analyzing a spectral interferogram. In combination with a simultaneously measured power spectrum, a real-time calculation and visualization of the spectral and temporal amplitude as well as phase can be performed.



- Short pulse characterization down to <math><5\text{ fs}</math>
- Available solutions for the VIS, NIR and IR range
- Real-time and single-shot measurement of phase and intensity
- High level of automated software support and internal camera assisted alignment
- Full software suite included
- Ideal for broadband Ti:Sa oscillators, hollow-core fiber compressors, and NOPA

*Spectral Phase Interferometry for Direct Electric-field Reconstruction;

International Patent No.: EP 1000315, WO 1999/006794

FC Spider Specifications

FC Spider	VIS	NIR	IR
Center wavelength	~500 nm ~600 nm ~700 nm	~800 nm	~1030 nm
Spectral bandwidth	5 nm ... 50 nm for ~500 nm 10 nm ... 80 nm for ~600 nm 20 nm ... 100 nm for ~700 nm	25 nm ... 200 nm	50 nm ... 200 nm Optional: 50 nm ... 300 nm
Transform limited pulse width	8 fs ... 75 fs for ~500 nm 7 fs ... 50 fs for ~600 nm 7 fs ... 35 fs for ~700 nm	<5 fs ... 40 fs	7 fs ... 30 fs Optional: 5 fs ... 30 fs
Maximum pulse width (chirped)	120 fs	200 fs	200 fs
Laser repetition rate	Any, single shot (<20 Hz)		>100 Hz
Trigger	TTL, for laser repetition rate <20 Hz		TTL, for laser repetition rate 100 Hz ... 10 kHz
Interface	USB 2.0		

Input requirements:

Laser pulse energies	0.2 nJ ... 8 nJ for MHz repetition rates <10 μ J for kHz repetition rates ~10 μ J for Hz repetition rates / single shot
Polarization	Linear, horizontal
Beam diameter	<5 mm
Beam height	72 mm ... 106 mm (spectral phase and intensity) 87 mm ... 121 mm (spectral intensity)

Options:

Wavelength	Others on request, please ask
External beam splitter and beam routing kit	On request, please ask
Notebook	on request, please ask with pre-installed Spider software

Spider NIR or IR Central Wavelength

Towards Short Pulses at 0.8 or 1 μm Central Wavelength

The Spider IR is a precision tool optimized for the complete spectral and temporal characterization of laser pulses in the infrared. Based on the patented Spider* technology, it extends the existing range of APE Spider models to cover longer pulses, between 15 fs to 200 fs at 0.8 μm center wavelength or alternatively between 30 fs and 500 fs at around 1 μm .

It also supports detection of the chirp sign for stretched pulses greater than 2 ps width, making it a smart choice for the alignment of pulse compressors.

Furthermore, the Spider IR control software supports real-time calculation of the temporal amplitude and phase. The user-friendly design features highly automated software to guide the operator through calibration and alignment procedures and enable measurements to be executed with a minimum of data input.



- Best choice for pulses between 15 fs to 200 fs at 0.8 μm and 30 fs to 500 fs at 1 μm central
- Spectral intensity and phase measurement as well as temporal intensity and phase reconstruction
- Real-time and true single-shot measurement of intensity and phase
- High level of automated software support and internal camera-assisted alignment
- Full software suite included

*Spectral Phase Interferometry for Direct Electric-field Reconstruction; International Patent No.: EP 1000315, WO 1999/006794

Spider Specifications

Spider	NIR	IR
Center wavelength	750 nm ... 900 nm	970 nm ... 1070 nm
Spectral bandwidth	15 nm ... 60 nm	7 nm ... 50 nm
Transform limited pulse width	15 fs ... 60 fs	30 fs ... 200 fs
Maximum pulse width (chirped)	200 fs	500 fs
Laser repetition rate	Any, single shot (<20 Hz)	
Trigger for single shot measurements	TTL, for laser repetition rate <20 Hz	
Interface	USB 2.0	
Notebook	Included with pre-installed software	

Input requirements:

Laser pulse energies	0.2 nJ ... 8 nJ for MHz repetition rates <10 μ J for kHz repetition rates ~10 μ J for Hz repetition rates / single shot
Polarization	Linear, horizontal
Beam diameter	<5 mm
Beam height	72 mm ... 106 mm (spectral phase and intensity) 87 mm ... 121 mm (spectral intensity)

Options:

Wavelength	Others on request, please ask
External beam splitter and beam routing kit	On request, please ask
Notebook	on request, please ask with pre-installed Spider software

Appendix Technical Drawings

All dimensions in mm

FC Spider

- Measurement of very short pulses with only a few cycles

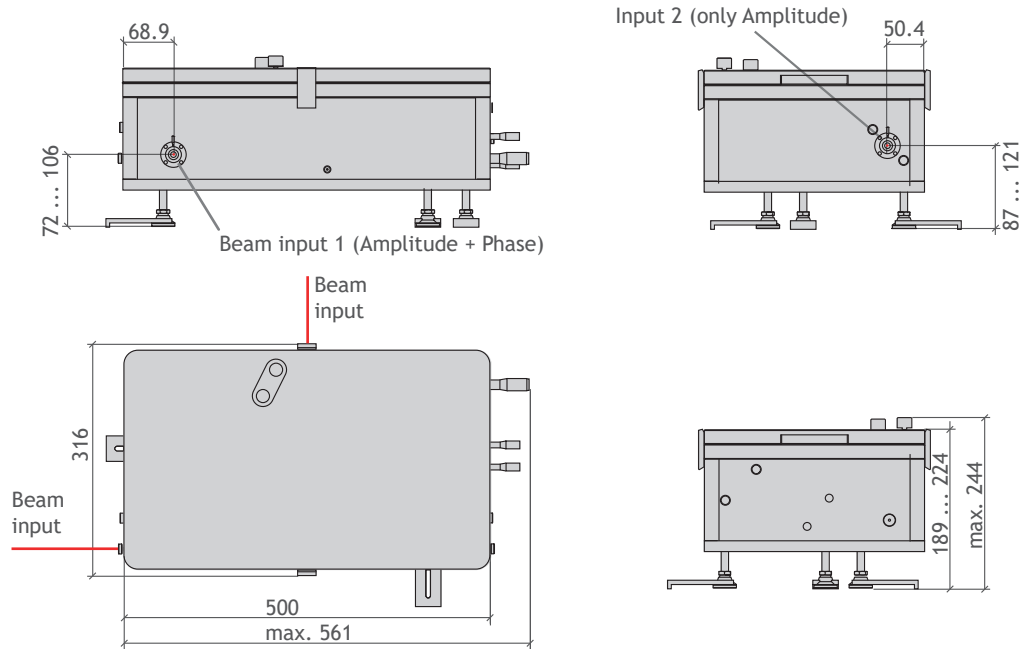

Spider

- Measurement at center wavelength of around 0.8 μm or 1 μm

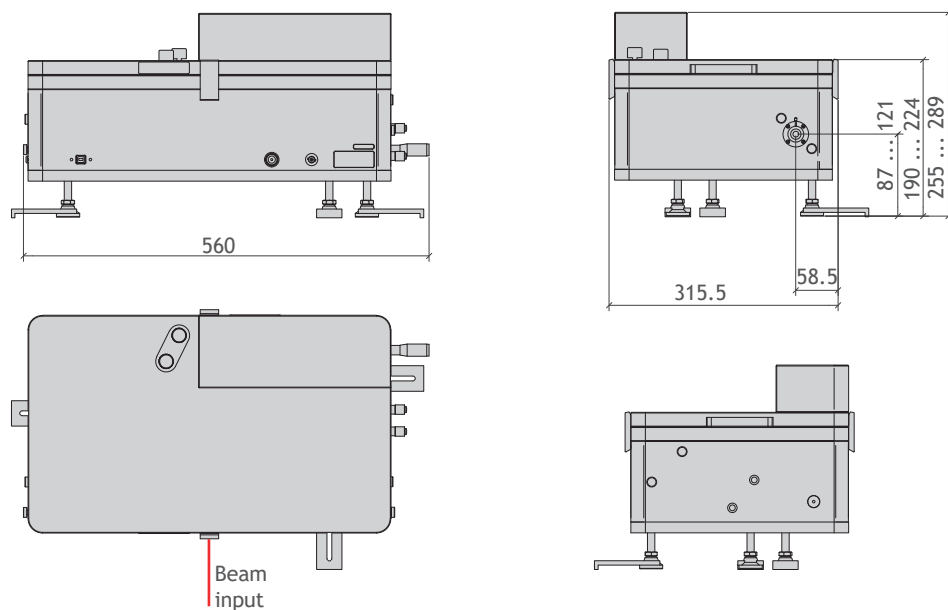



Contact

APE Angewandte Physik & Elektronik GmbH
Plauener Str. 163-165 | Haus N | 13053 Berlin | Germany
T: +49 30 986 011-30
F: +49 30 986 011-333
E: sales@ape-berlin.de
www.ape-berlin.de

APE follows a policy of continued product improvement.
Therefore, specifications are subject to change without notice.

© APE GmbH | Rev. 4.3.1

**PHOTO
TECHNICA** www.phototechnica.co.jp
フォトテクニカ株式会社
〒336-0017 埼玉県さいたま市南区南浦和 2-18-2
TEL:048-871-0067 FAX:048-871-0068
e-mail:voc@phototechnica.co.jp