

NT240 SERIES



Broadly Tunable kHz Pulsed DPSS Lasers

FEATURES

- ▶ Customers recognized reliability
- ▶ Two years warranty
- ▶ Integrates DPSS pump laser and OPO into a single housing
- ▶ Hands-free no-gap wavelength tuning from 210 to 2600 nm*
- ▶ 1000 Hz pulse repetition rate
- ▶ More than 60 μJ output pulse energy in UV
- ▶ Less than 5 cm⁻¹ linewidth
- ▶ 3–6 ns pulse duration
- ▶ Remote control via key pad or PC
- ▶ Optional separate output for the OPO pump beam 355 nm, 532 nm or 1064 nm

* Automatic wavelength scan is programmable

BENEFITS

- ▶ Hands-free wavelength tuning – no need for physical intervention
- ▶ High repetition rate 1000 Hz enables fast data collection
- ▶ End pumping with diode technology ensures high reliability and low maintenance costs
- ▶ Narrow linewidth (down to 3 cm⁻¹) and superior tuning resolution (1–2 cm⁻¹) allow recording of high quality spectra
- ▶ High integration level saves valuable space in the laboratory
- ▶ In-house design and manufacturing of complete systems, including pump lasers, guarantees on-time warranty and post warranty services and spares supply
- ▶ Variety of control interfaces: USB, RS232, LAN and WLAN ensures easy control and integration with other equipment
- ▶ Attenuator and fiber coupling options facilitate incorporation of NT240 systems into various experimental environments

APPLICATIONS

- ▶ Laser-induced fluorescence spectroscopy
- ▶ Pump-probe spectroscopy
- ▶ Non-linear spectroscopy
- ▶ Time-resolved spectroscopy
- ▶ Photobiology
- ▶ Remote sensing
- ▶ Determination of the telescope throughput

NT240 series lasers produce pulses at an unprecedented 1 kHz pulse repetition rate, tunable over a broad spectral range. Integrated into a single compact housing, the diode pumped Q-switched Nd:YAG laser and OPO offers hands-free, no-gap tuning from 210 to 2600 nm. With its 1000 Hz repetition rate, the NT240 series laser establishes itself as a versatile tool for many laboratory applications, including laser induced fluorescence, flash photolysis, photobiology, metrology, remote sensing, etc.

NT240 series systems can be controlled from a remote control pad or/and a computer using supplied LabVIEW™ drivers. The control pad allows easy control of all parameters and features on a backlit display that is easy to read even with laser safety eyewear.

Thanks to a DPSS pump source, the laser requires little maintenance. It is equipped with air-cooled built-in chiller, which further reduces running costs. A built-in OPO pump energy monitor allows monitoring of pump

laser performance without the use of external power meters. The optional feature provides a separate output port for the 1064, 532 or 355 nm beam.

SPECIFICATIONS ¹⁾

Model	NT242	NT242-SH	NT242-SF	NT242-SH/SF
OPO				
Wavelength range				
Signal	405–710 nm			
Idler	710–2600 nm			
SH and SF	—	210–300 nm	300–405 nm	210–405 nm
Pulse energy ²⁾				
OPO	450 μJ			
SH and SF	—	40 μJ at peak	60 μJ at peak	
Pulse repetition rate				
1000 Hz				
Pulse duration ³⁾				
3–6 ns				
Linewidth ⁴⁾				
< 5 cm ⁻¹				
Minimal tuning step ⁵⁾				
Signal	1 cm ⁻¹			
Idler	1 cm ⁻¹			
SH and SF	—	2 cm ⁻¹		
Polarization				
Signal	horizontal			
Idler	vertical			
SH and SF	—	vertical		
Typical beam diameter ⁶⁾				
3 × 6 mm				
PUMP LASER				
Pump wavelength ⁷⁾				
		355 nm	355 / 1064 nm	
Typical pump pulse energy ⁸⁾				
		3 mJ	3 / 1 mJ	
Pulse duration ³⁾				
4–6 ns at 1064 nm				
PHYSICAL CHARACTERISTICS				
Unit size (W × L × H) ⁹⁾				
456 × 1040 × 297 mm				
Power supply size (W × L × H)				
520 × 400 × 286 mm				
Umbilical length				
2.5 m				
OPERATING REQUIREMENTS				
Cooling				
built-in chiller				
Room temperature				
18–27 °C				
Relative humidity				
20–80 % (non-condensing)				
Power requirements				
100–240 V AC, single phase 50/60 Hz				
Power consumption				
< 1.5 kW				
Cleanliness of the room				
not worse than ISO Class 9				

¹⁾ Due to continuous improvement, all specifications are subject to change. Parameters marked typical are illustrative; they are indications of typical performance and will vary with each unit we manufacture. Unless stated otherwise, all specifications are measured at 450 nm and for basic system without options.

²⁾ See tuning curves for typical outputs at other wavelengths.

³⁾ Measured at FWHM level with photodiode featuring 1 ns rise time and 300 MHz bandwidth oscilloscope.

⁴⁾ Linewidth is <8 cm⁻¹ for 210–405 nm range.

⁵⁾ For manual input from PC. When wavelength is controlled from keypad, tuning resolution is 0.1 nm for signal, 1 nm for idler and 0.05 nm for SH and SF.

⁶⁾ Beam diameter is measured at 450 nm at the 1/e² level and can vary depending on the pump pulse energy.

⁷⁾ Separate output port for the 3rd and other harmonic is optional.

⁸⁾ The pump laser pulse energy will be optimized for best OPO performance. The actual pump laser output can vary with each unit we manufacture.

⁹⁾ Length from 1040 to 1233 mm depending on configuration.



Accessories and optional items

Option	Features
-SH	Tuning range extension in UV range (210–300 nm) by second harmonic generation
-SF	Tuning range extension in 300–405 nm range by sum-frequency generation
-SH/SF	Tuning range extension in 210 – 405 nm range by combining second harmonics and sum-frequency generator outputs for maximum possible pulse energy
-SCU	Spectral filtering accessory for improved spectral purity of pulses
-H, -2H, -3H	1064, 532 and 355 nm output via separate port
-FC	Fiber coupled output in 350 – 2000 nm range
-Attn	Attenuator output in 210 – 2600 nm range

PERFORMANCE

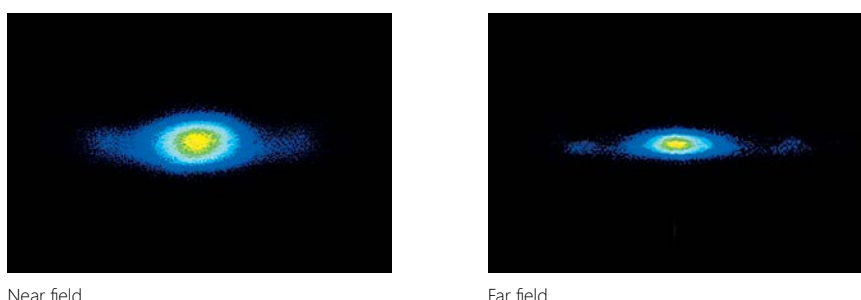

Fig 1. Typical beam profiles of NT242 series lasers at 500 nm

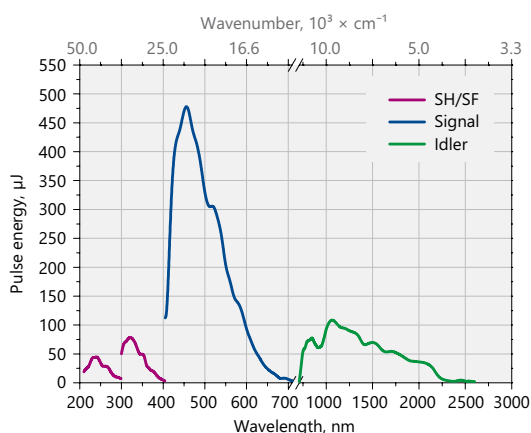

Fig 2. Typical output pulse energy of NT242 series tunable laser

OUTLINE DRAWINGS

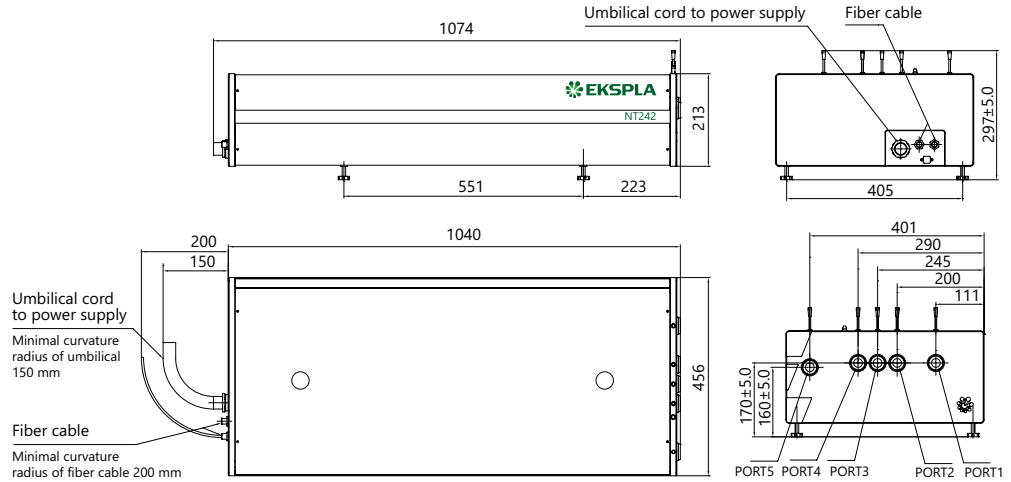

Fig 3. NT242 series laser head dimensions

ORDERING INFORMATION

Note: Laser must be connected to the mains electricity all the time. If there will be no mains electricity for longer than 1 hour then laser (system) needs warm up for a few hours before switching on.

NT242-SH-H-2H-SCU

Model	Options:
Optional tuning range extension:	H → extra 1064 nm output
SH → 210–300 nm	2H → extra 532 nm output
SF → 300–405 nm	SCU → spectral filtering accessory
SH/SF → 210–405 nm	

**PHOTO
TECHNICA** www.phototechnica.co.jp
フォトテクニカ株式会社
 〒336-0017 埼玉県さいたま市南区南浦和 2-18-2
 TEL:048-871-0067 FAX:048-871-0068
 e-mail:voc@phototechnica.co.jp

NT250 SERIES

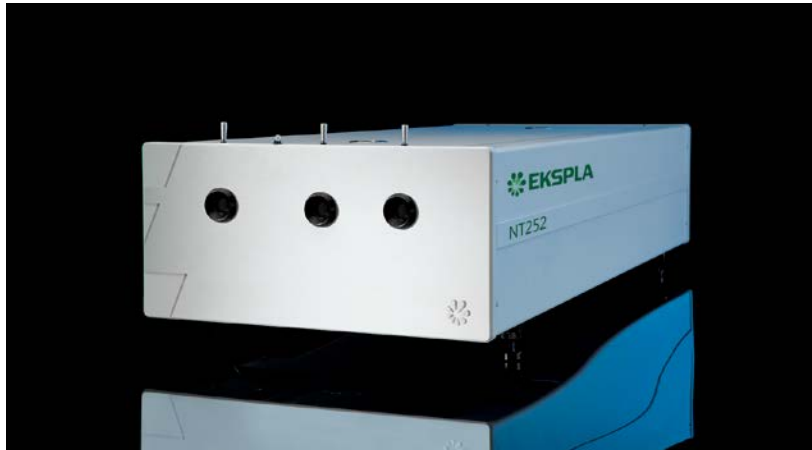

BENEFITS

- ▶ Hands-free wavelength tuning – no need for physical intervention
- ▶ High repetition rate (1000 Hz) enables fast data collection
- ▶ End diode pumping and water-free technology ensure high reliability and low maintenance costs
- ▶ Superior tuning resolution ($1 - 2 \text{ cm}^{-1}$) allows recording of high quality spectra
- ▶ High integration level saves valuable space in the laboratory
- ▶ In-house design and manufacturing of complete systems, including pump lasers, guarantees on-time warranty and post warranty services and spares supply
- ▶ Variety of control interfaces: USB, RS232, LAN and WLAN ensures easy control and integration with other equipment
- ▶ Attenuator and fiber coupling options facilitate incorporation of NT250 systems into various experimental environments

NT250 series tunable laser systems integrates into a single compact housing a nanosecond Optical Parametric Oscillator (OPO) and Diode-Pumped Solid-State (DPSS) Q-switched pump laser.

Diode pumping enables fast data acquisition at high pulse repetition rates up to 1 kHz while avoiding frequent flashlamp changes that are common when flashlamp pumped lasers are used. Special cooling technology eliminates the need for tap water, thus further reducing running and maintenance costs.

All lasers feature motorized tuning across the specified tuning range. The output wavelength can be set from control pad with backlit display that is easy to read even while wearing laser safety glasses. Alternatively, the laser can be also controlled from personal computer using supplied LabVIEW™ drivers.

High conversion efficiency, stable output, easy maintenance and compact size make our systems excellent choice for many applications.

Tunable Wavelength UV-NIR Range DPSS Lasers

FEATURES

- ▶ Customers recognized reliability
- ▶ Two years warranty
- ▶ Integrates DPSS pump laser and OPO into a single housing
- ▶ Dry, no water inside!
- ▶ Hands-free no-gap wavelength tuning from 335 to 2600 nm*
- ▶ 1000 Hz pulse repetition rate
- ▶ More than 1.1 mJ output pulse energy in NIR
- ▶ 1–4 ns pulse duration
- ▶ Remote control via key pad or PC

* Automatic wavelength scan is programmable

APPLICATIONS

- ▶ Photoacoustic imaging
- ▶ Laser-induced fluorescence spectroscopy
- ▶ Pump-probe spectroscopy
- ▶ Photobiology
- ▶ Remote sensing
- ▶ Metrology

Accessories and Optional Items

Option	Features
-SH	Tuning range extension in UV range (335 – 670 nm) by second harmonic generation
-H, -2H	1064 and 532 nm output via separate port
-FC	Fiber coupled output in 350 – 2000 nm range
-Attn	Attenuator output in 335 – 2600 nm range

SPECIFICATIONS ¹⁾

Model		NT252
OPO		
Wavelength range		
Signal		670–1064 nm
Idler		1065–2600 nm
SH		335–669 nm
Pulse energy		
OPO ²⁾		1100 µJ
SH ³⁾		200 µJ
Pulse duration ⁴⁾		1–4 ns
Pulse repetition rate		1000 Hz
Linewidth ⁵⁾		<10 cm ⁻¹
Minimal tuning step ⁶⁾		
Signal		1 cm ⁻¹
Idler		1 cm ⁻¹
SH		2 cm ⁻¹
Polarization		
Signal		horizontal
Idler		vertical
SH		horizontal
Typical beam diameter ^{7) 8)}		3 × 6 mm
PUMP LASER		
Pump wavelength ⁹⁾		532 nm
Typical pump pulse energy ¹⁰⁾		4 mJ
Pulse duration ¹¹⁾		2 – 5 ns
Pulse energy stability (StdDev)		<2.5 %
PHYSICAL CHARACTERISTICS		
Unit size (W × L × H)		456 × 1040 × 297 mm
Power supply size (W × L × H)		520 × 400 × 286 mm
Umbilical length		2.5 m
OPERATING REQUIREMENTS		
Cooling		air-cooled
Room temperature		18–27 °C
Relative humidity		20–80 % (non-condensing)
Power requirements		100–240 V AC, single phase 50/60 Hz
Power consumption		<1.5 kW
Cleanliness of the room		not worse than ISO Class 9

¹⁾ Due to continuous improvement, all specifications are subject to change. Parameters marked typical are illustrative; they are indications of typical performance and will vary with each unit we manufacture. Unless stated otherwise, all specifications are measured at 750 nm and for basic system without options.

²⁾ Measured at maximum in the interval 700 – 750 nm. See tuning curves for typical outputs at other wavelengths.

³⁾ Measured at 400 nm. See tuning curves for typical outputs at other wavelengths.

⁴⁾ Measured at FWHM level with photodiode featuring 1 ns rise time and 300 MHz bandwidth oscilloscope.

⁵⁾ In signal and idler range.

⁶⁾ For manual input from PC. When wavelength is controlled from keypad, tuning resolution is 0.1 nm for signal, 1 nm for idler and 0.05 nm for SH.

⁷⁾ Measured at the wavelength indicated in the “Pulse energy” specification row.

⁸⁾ Beam diameter is measured at the 1/e² level at the laser output and can vary depending on the pump pulse energy.

⁹⁾ Separate output port for the 2nd and other harmonic are optional.

¹⁰⁾ The pump laser pulse energy will be optimized for best OPO performance. The actual pump laser output can vary with each unit we manufacture.

¹¹⁾ Measured at FWHM level with photodiode featuring 1 ns rise time and 300 MHz bandwidth oscilloscope.



PERFORMANCE

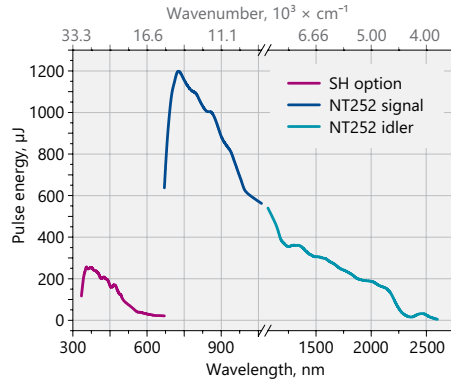

Fig 1. Typical output pulse energy of the NT252-SH tunable laser

OUTLINE DRAWINGS

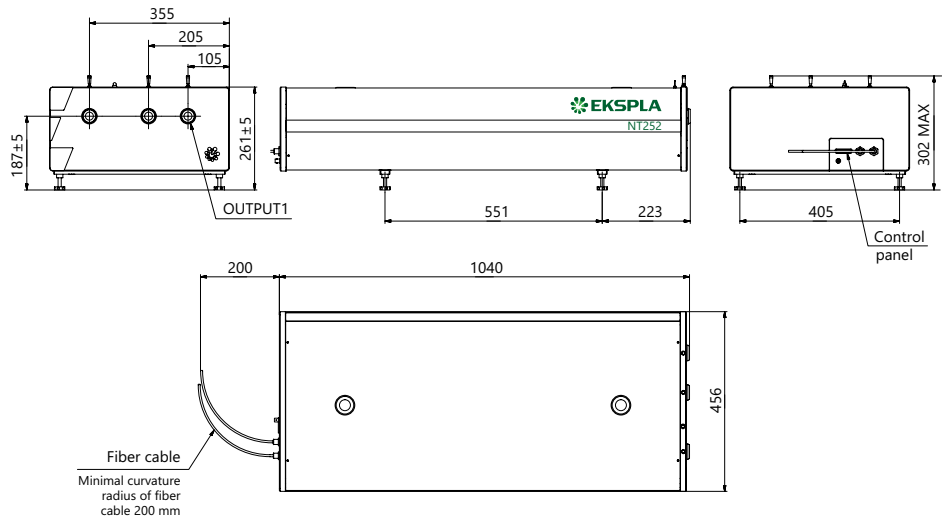

Fig 3. NT252 series laser head dimensions

ORDERING INFORMATION

Note: Laser must be connected to the mains electricity all the time. If there will be no mains electricity for longer than 1 hour then laser (system) needs warm up for a few hours before switching on.

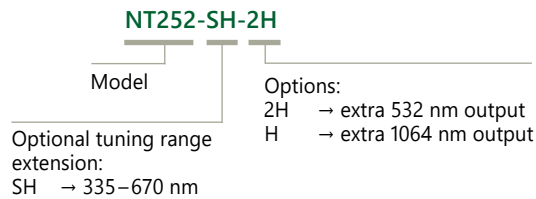
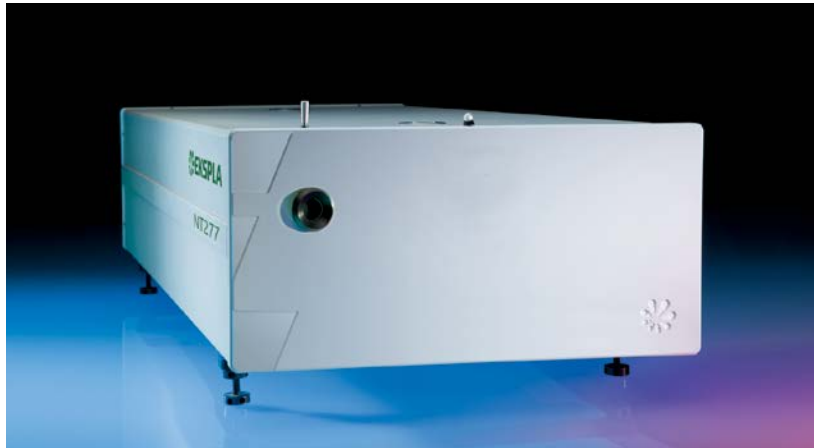

PHOTO TECHNICA www.phototechnica.co.jp
 フォトテクニカ株式会社
 〒336-0017 埼玉県さいたま市南区南浦和 2-18-2
 TEL:048-871-0067 FAX:048-871-0068
 e-mail:voc@phototechnica.co.jp

NT270 SERIES



BENEFITS

- ▶ Hands-free wavelength tuning – no need for physical intervention
- ▶ Wide (2500 – 4475 nm) tuning range is highly useful for s-SNOM and other IR applications
- ▶ NT270 is the cost effective solution covering a wide tuning range from a single source
- ▶ End pumping with diode technology ensures high reliability and lots of fired shots leading to low maintenance costs
- ▶ High integration level saves valuable space in the laboratory
- ▶ Air cooling eliminates the need for water, ensuring easy operation and simple installation or integration
- ▶ In-house design and manufacturing of complete systems, including pump lasers, guarantees on-time warranty and post warranty services and spares supply
- ▶ Variety of control interfaces: USB, RS232, LAN and WLAN ensures easy control and integration with other equipment

NT270 series tunable laser systems integrate into a single compact housing a nanosecond Optical Parametric Oscillator (OPO) and Diode-Pumped Solid-State (DPSS) Q-switched pump laser.

Diode pumping enables fast data acquisition at high pulse repetition rates up to 1 kHz while avoiding frequent flashlamp changes that are common when flashlamp pumped lasers are used.

The pump lasers do not require water for cooling, thus further reducing running and maintenance costs.

All lasers feature motorized tuning across the specified tuning range. The output wavelength can be set from control pad with backlit display that is easy to read even while wearing laser safety glasses. Alternatively, the laser can be controlled also from personal computer using supplied LabVIEW™ drivers.

Tunable Wavelength NIR-MIR Range DPSS Lasers

FEATURES

- ▶ Customers recognized reliability
- ▶ Two years warranty
- ▶ Integrates DPSS pump laser and OPO into single housing
- ▶ Separate output ports for the pump laser and OPO beams
- ▶ OPO output wavelength range from **2500 nm to 4475 nm**
- ▶ Narrow linewidth
- ▶ Hands-free, fast wavelength tuning*
- ▶ <7 ns pulse duration
- ▶ Remote control via key pad or PC

* Including automatic wavelength scan

APPLICATIONS

- ▶ Scanning Near-field Optical Microscopy (s-SNOM) microscopy
- ▶ Single molecule vibrational spectroscopy
- ▶ IR spectroscopy
- ▶ Gas spectroscopy

High conversion efficiency, stable output, easy maintenance and compact size make our systems excellent choice for lots of applications.

SPECIFICATIONS ¹⁾

Model	NT277
OPO	
Wavelength range ²⁾	
Idler	2500–4475 nm
Pulse energy ³⁾	
Idler	80 μJ at 3000 nm
Pulse duration ⁴⁾	5–7 ns
Pulse repetition rate	1000 Hz
Linewidth ⁵⁾	<10 cm ⁻¹
Minimal tuning step ⁶⁾	
Idler	1 cm ⁻¹
Polarization	vertical
Typical beam diameter ^{7) 8)}	4 mm
PUMP LASER	
Pump wavelength	1064 nm
Typical pump pulse energy ⁹⁾	1.9 mJ
Pulse duration ¹⁰⁾	<10 ns
Beam quality	fit to Gaussian >90%
Pulse energy stability (StdDev)	<0.5 %
PHYSICAL CHARACTERISTICS	
Unit size (W × L × H)	305 × 701 × 270 mm
Power supply size (W × L × H)	449 × 376 × 140 mm
Umbilical length	2.5 m
OPERATING REQUIREMENTS	
Cooling	by air
Room temperature	18–27 °C
Relative humidity	20–80 % (non-condensing)
Power requirements	100–240 V AC, single phase 50/60 Hz
Power consumption	< 0.5 kW
Cleanliness of the room	not worse than ISO Class 9

¹⁾ Due to continuous improvement, all specifications are subject to change. Parameters marked typical are illustrative; they are indications of typical performance and will vary with each unit we manufacture. Unless stated otherwise all specifications are measured at 3000 nm and for basic system without options.

²⁾ Available wavelength range. Inquire for custom IR option with tuning up to 12 μm.

³⁾ See tuning curves for typical outputs at other wavelengths.

⁴⁾ Measured art FWHM level with photodiode featuring 1 ns rise time and 300 MHz bandwidth oscilloscope.

⁵⁾ Higher energy 10 – 150 cm⁻¹ option is available for 2500 – 4475 nm tuning range. Narrow linewidth (<10 cm⁻¹) operation mode is impossible with this option.

⁶⁾ For manual input from PC. When wavelength is controlled from keypad, tuning resolution is 1 nm.

⁷⁾ Measured at the wavelength indicated in the “Pulse energy” specification row.

⁸⁾ Beam diameter is measured at the 1/e² level at the laser output and varies depending on the wavelength.

⁹⁾ The pump laser pulse energy will be optimized for the best OPO performance. The actual pump laser output can vary with each unit we manufacture.

¹⁰⁾ Measured at FWHM level with photodiode featuring 1 ns rise time and 300 MHz bandwidth oscilloscope.



Note: Laser must be connected to the mains electricity all the time. If there will be no mains electricity for longer that 1 hour then laser (system) needs warm up for a few hours before switching on.

PERFORMANCE

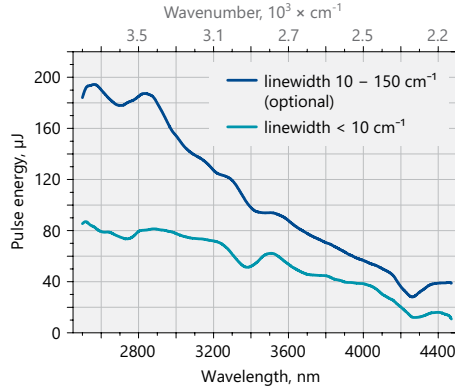

Fig 1. Typical output pulse energy of the NT277 and NT277-XIR tunable laser

OUTLINE DRAWINGS

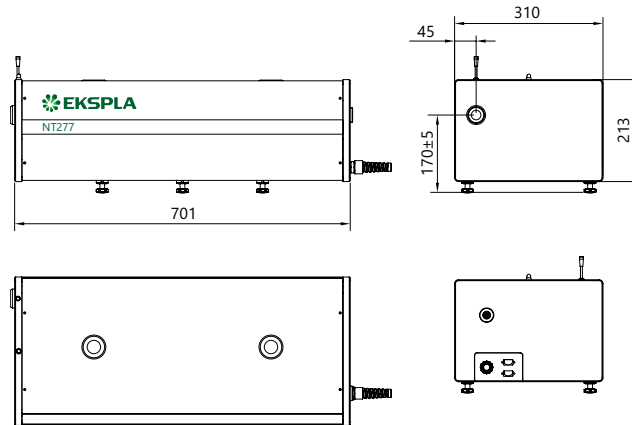

Fig 3. NT277 series laser head dimensions

**PHOTO
TECHNICA** www.phototechnica.co.jp
フォトテクニカ株式会社
 〒336-0017 埼玉県さいたま市南区南浦和 2-18-2
 TEL:048-871-0067 FAX:048-871-0068
 e-mail:voc@phototechnica.co.jp