

# HARPIA | TA

## Ultrafast Spectroscopy System

Excellent performance at high repetition rates

Measurement range from UV to MIR

Market-leading sensitivity

Modules for time-resolved fluorescence, and multi-pulse experiments

High-level automation in a compact footprint



Layout example

### Specifications

Configuration	UV-VIS	UV-VIS-NIR	MIR
Probe spectral range	350 – 1100 nm <sup>1)</sup>	350 – 1600 nm <sup>1)</sup>	2000 – 13 000 nm <sup>2)</sup>
Pump range	240 – 2200 nm <sup>2)</sup>		450 – 2200 nm <sup>3)</sup>
Delay range (resolution)	8 ns (8.3 fs)		4 ns (4.2 fs)
Temporal resolution	≤ laser pulse duration		
Laser repetition rate	1 – 100 kHz		
Maximum data acquisition rate	3850 Hz		100 kHz
Modes	Reflection and transmission		

<sup>1)</sup> Pump-probe measurements using Yb-based laser systems may exhibit blind spots at 515 nm and 1030 nm, corresponding to the second harmonic and fundamental wavelength of the laser, where strong pump scattering can interfere with accurate detection.

<sup>2)</sup> The range is determined by the OPA's output spectrum.

<sup>3)</sup> The wavelength range is configurable to 240 – 700 nm. Contact [sales@lightcon.com](mailto:sales@lightcon.com) for more details.

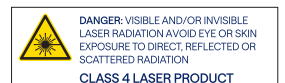

HARPIA-TA optical layout for pump-probe experiments

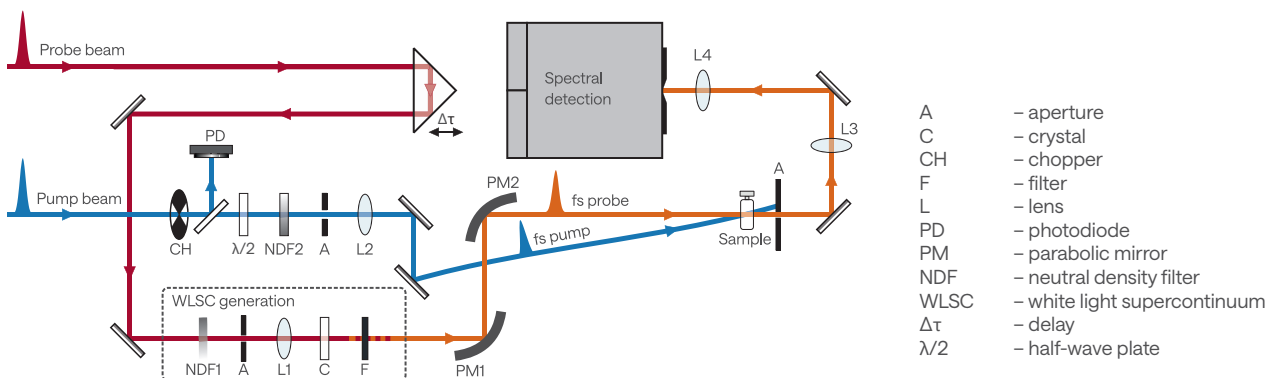

# HARPIA | TF Time-Resolved Fluorescence Module

## Kerr gate

Ideal for femtosecond fluorescence measurements. Simpler alignment and maintenance. The entire spectrum is measured at once.

## Fluorescence upconversion (FU)

Better temporal resolution for measuring fast fluorescence events.

## Time-correlated single-photon counting (TCSPC)

Fluorescence lifetime measurements are extendible to measure phosphorescence signals.

Time-resolved fluorescence spectroscopy provides valuable insights into molecular processes occurring in the excited states. The HARPIA-TF module combines different measurement modes, enabling the observation of fluorescence dynamics across different time scales. By employing high-repetition-rate CARBIDE or PHAROS lasers, fluorescence dynamics can be measured while exciting the samples with pulse energies as low as several nanojoules.

## Specifications

Module	HARPIA-TF		
	Kerr gate	Fluorescence upconversion	TCSPC
Measurement technique	Kerr gate	Fluorescence upconversion	TCSPC
Spectral range	380 – 1000 nm	330 – 820 nm <sup>1) 2)</sup>	220 – 820 nm <sup>3)</sup>
Pump range	240 – 2200 nm <sup>4)</sup>		
Temporal resolution	≤ 1 ps	≤ 1.4 x laser pulse duration	< 180 ps or < 50 ps
Delay range (resolution)	8 ns (8.3 fs)		5 μs <sup>5)</sup>
Compatible with	TCSPC		Kerr gate or fluorescence upconversion
Detector	CCD	PMT	
Modes	Transmission		Reflection and transmission

<sup>1)</sup> The fluorescence detection range is extendable up to 1600 nm. Contact sales@lightcon.com for more details.

<sup>2)</sup> Fluorescence detection may exhibit blind spots at 343 nm, 515 nm, and 1030 nm due to harmonic overlap.

<sup>3)</sup> The spectral range is extendable with an additional NIR detector (measurement range 1000 – 1700 nm). Contact sales@lightcon.com for more details.

<sup>4)</sup> The range is determined by the OPA's output spectrum.

<sup>5)</sup> Using FIFO-based acquisition, the temporal window can be extended up to ~1 s for monitoring longer-timescale processes.

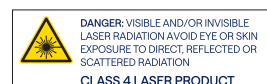

## Principle of Kerr gate spectroscopy

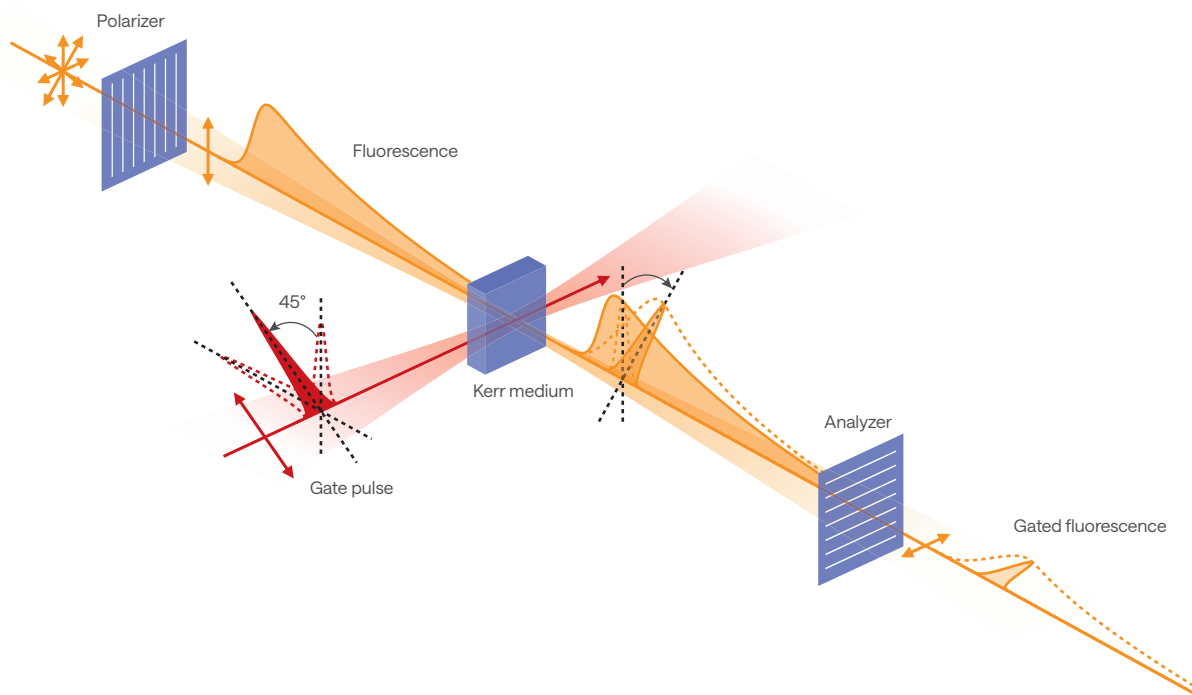

# HARPIA | TA-FP Flash Photolysis – Nanosecond TA Module

The flash photolysis experiment is designed to measure the long-lived states of molecular systems. Its principle is analogous to the femtosecond transient absorption (TA) experiment but with a delay in the nanosecond to millisecond range.

In femtosecond transient absorption, the delay between pump and probe pulses is controlled by moving a mechanical delay stage. In contrast, flash photolysis employs a delayed probe pulse generated by an electronically triggered external probe laser – a broadband nanosecond photonic crystal fiber (PCF) laser.

## Specifications

Module	HARPIA-TA-FP		HARPIA-TA-FP-UV	
	UV-VIS	UV-VIS-NIR	UV-VIS	UV-VIS-NIR
HARPIA-TA configuration				
Probe spectral range <sup>1)</sup>	450 – 1100 nm	450 – 1600 nm	350 – 1100 nm	350 – 1600 nm
Pump range	240 – 2200 nm <sup>2)</sup>			
Delay range	up to 485 $\mu$ s			
Temporal resolution	2 ns		1 ns	
Probe laser repetition rate	1850 Hz			
Maximum data acquisition rate	3850 Hz			
Modes	Reflection and transmission			

<sup>1)</sup> Pump-probe measurements using nanosecond laser systems may exhibit blind spots at 1064 nm, corresponding to the fundamental wavelength of the laser.

<sup>2)</sup> The range is determined by the OPA's output spectrum.

# HARPIA | TB Third Beam Delivery Module

When standard spectroscopy tools are not enough to unravel the intricate ultrafast dynamics of photoactive systems, multi-pulse time-resolved spectroscopic techniques can be utilized to yield additional insight.

The HARPIA-TB module includes a Berek compensator for polarization control, a continuously variable neutral density filter for automated intensity control, and a delay line with a range of up to 4 ns.

### Femtosecond stimulated Raman scattering (FSRS)

Delivering frequency-narrowed picosecond pulses enables FSRS measurements, a relatively recent yet increasingly adopted time-resolved spectroscopy technique for observing changes in the vibrational structure of optically excited molecular systems.

### Multi-pulse time-resolved transient absorption

Enables control over photochemical reactions and access to higher excited states. Precisely timed pulse sequences can initiate a photoreaction and perturb it at defined moments during its evolution. In some cases, an additional pump pulse can re-excite molecules, with the delay between several pump pulses influencing the reaction's outcome.

## Specifications

Module	HARPIA-TB	
Measurement technique	FSRS <sup>1)</sup>	Pump for multi-pulse experiments
Probe spectral range	350 – 1100 nm <sup>2)</sup>	Depends on the HARPIA-TA configuration
Raman spectral range	700 – 2000 $\text{cm}^{-1}$	n/a
Acceptable wavelength range	450 – 2200 nm <sup>3)</sup>	
Delay range (resolution)	4 ns (4.2 fs)	
Modes	Transmission	

<sup>1)</sup> The results were obtained using a specific system configuration: a PHAROS femtosecond laser, an ORPHEUS-HE OPA, and an SHBC combined with an ORPHEUS-PS OPA. Measurements were performed at a 10 kHz repetition rate with a 540 nm actinic pump and a 450 nm Raman pump.  $\beta$ -carotene was used as the sample. Contact sales@lightcon.com for more details.

<sup>2)</sup> The system may exhibit blind spots at 515 nm and 1030 nm, corresponding to the second harmonic and fundamental wavelength of the laser, where strong pump scattering can interfere with accurate detection.

<sup>3)</sup> The wavelength range is configurable to 240 – 700 nm. Contact sales@lightcon.com for more details.

## Options



### Cryostat Mounting

HARPIA-TA supports cryostats that can be mounted externally or internally.

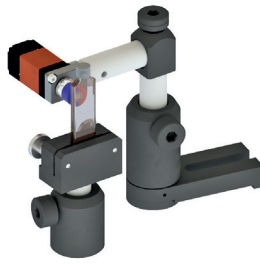

### Sample Stirrer

Liquid samples are mixed to avoid overexposure and ensure fresh samples.



### Motorized Pump Mirror

Used to automatically optimize pump and probe overlap.



### External Beam Steering

To lock the optical beam paths for OPA wavelengths (350 – 1100 nm).



### Beam Profiler

For checking beam shape/size at any position before/after measurement inside HARPIA.

## Performance at high repetition rates

The HARPIA spectroscopy system achieves an excellent signal-to-noise ratio at high repetition rates and low energy excitation conditions. The graphs below compare the

Measured difference absorption spectra of CdSe/ZnS quantum dots using low- and high-repetition rate lasers with 5 s acquisition time

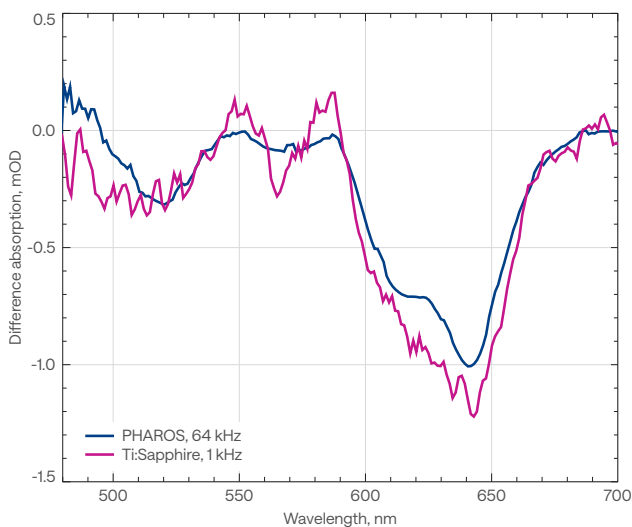

signal-to-noise ratio (SNR) of difference absorption spectra obtained with a Ti:Sapphire laser operating at 1 kHz and a PHAROS laser operating at 64 kHz with the same acquisition time.

Best-effort SNRs, achieved with HARPIA-TA spectrometer driven by a Ti:Sapphire laser at 1 kHz (magenta) and a PHAROS laser at 64 kHz (blue)

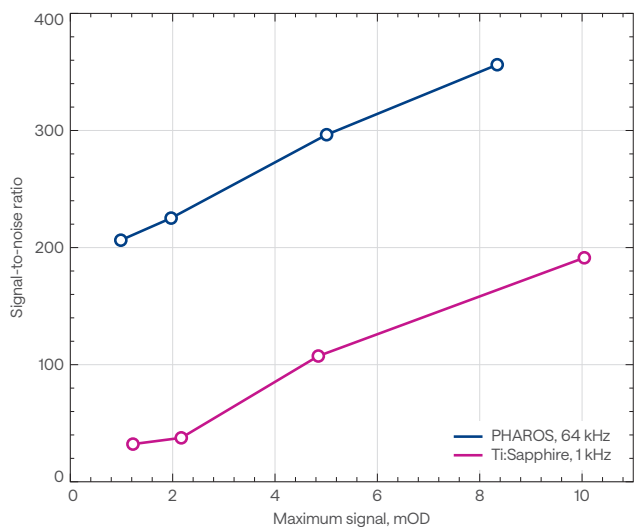

## Software

# HARPIA Service App

## Control and data acquisition software

A single software solution for all measurement modes, featuring:

- A user-friendly interface
- Measurement presets
- Measurement noise suppression
- Diagnostics and data export
- Continuous support and updates
- An API for remote experiment control using third-party software (LabVIEW, Python, MATLAB)

## Data analysis software

An ultrafast spectroscopy data analysis software, featuring:

- Advanced data wrangling: slicing, merging, cropping, smoothing, fitting, etc.
- Advanced global and target analysis
- Probe spectral chirp correction, calibration and deconvolution
- Support for 3D data sets (2D electronic spectroscopy, fluorescence lifetime imaging)
- Publication-ready figure preparation and data export

### HARPIA Service App main window

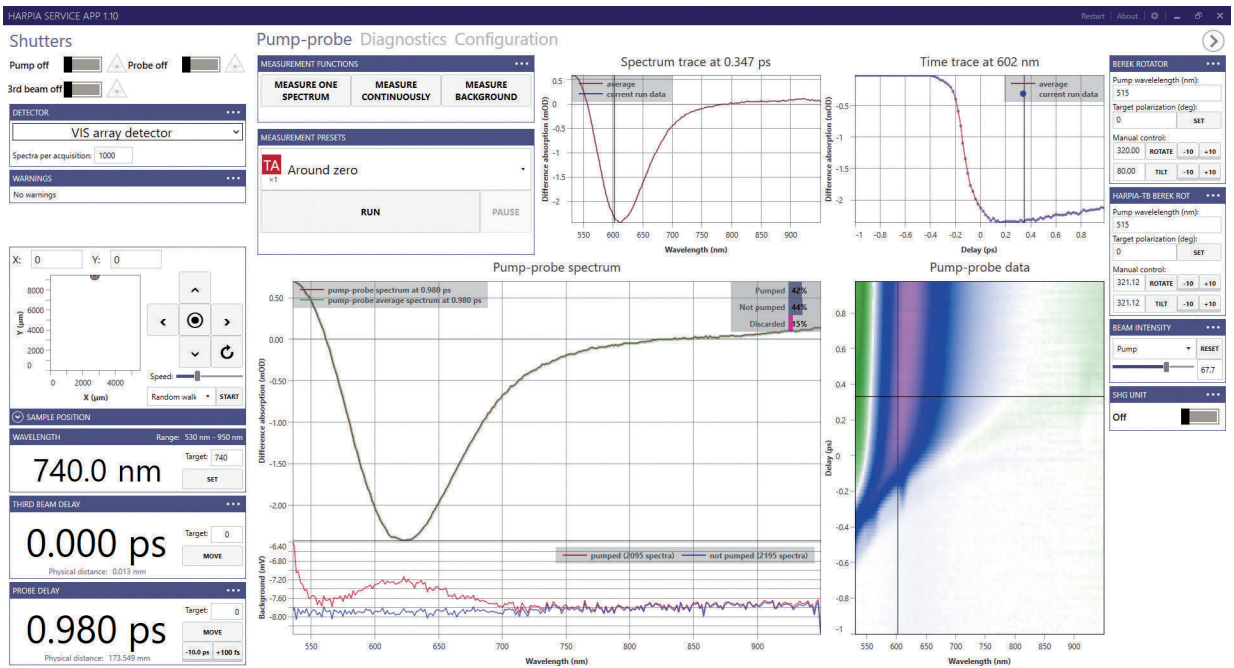

## Drawings

### HARPIA system with HARPIA-TB and HARPIA-TF modules

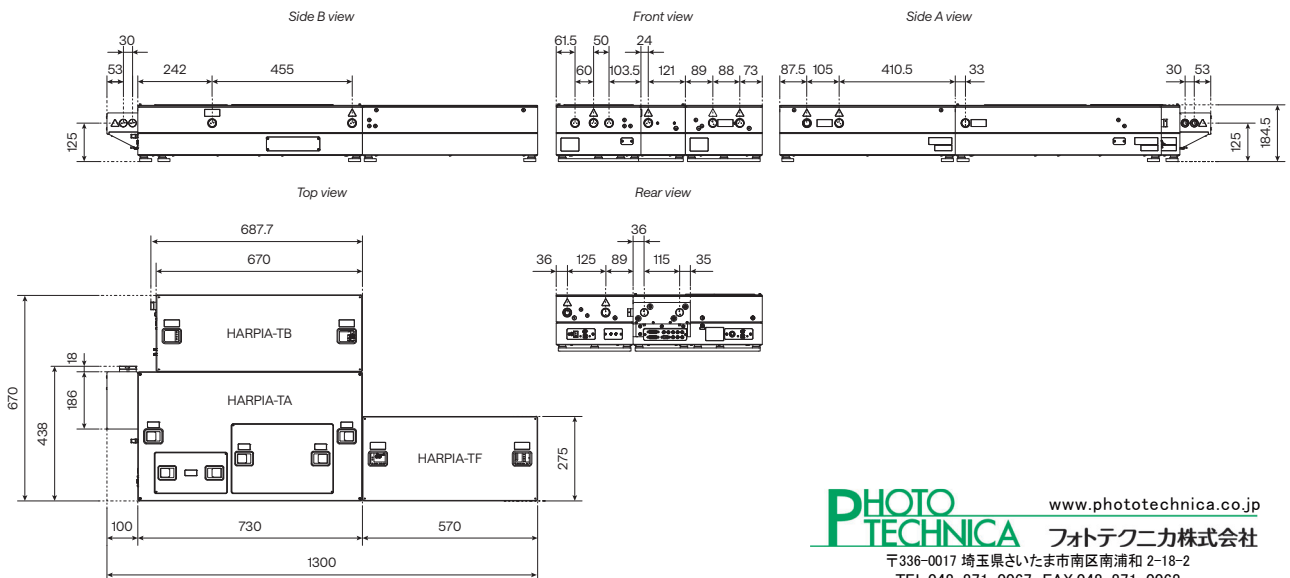

**PHOTO TECHNICA** www.phototechnica.co.jp  
 フォトテクニカ株式会社  
 〒336-0017 埼玉県さいたま市南区南浦和 2-18-2  
 TEL:048-871-0067 FAX:048-871-0068  
 e-mail:voc@phototechnica.co.jp